



Model Number

NJ10-30GKK-N

Features

- 10 mm flush
- Usable up to SIL2 acc. to IEC 61508

Accessories

BF 30
Mounting flange, 30 mm

Technical Data

General specifications

Switching element function		NAMUR, NC
Rated operating distance	s_n	10 mm
Installation		flush
Output polarity		NAMUR
Assured operating distance	s_a	0 ... 8.1 mm
Reduction factor r_{Al}		0.4
Reduction factor r_{Cu}		0.3
Reduction factor r_{304}		0.85

Nominal ratings

Nominal voltage	U_o	8.2 V (R_i approx. 1 k Ω)
Switching frequency	f	0 ... 300 Hz
Current consumption		
Measuring plate not detected		≥ 3 mA
Measuring plate detected		≤ 1 mA

Functional safety related parameters

MTTF _d	4560 a
Mission Time (T_M)	20 a
Diagnostic Coverage (DC)	0 %

Ambient conditions

Ambient temperature	-25 ... 100 °C (-13 ... 212 °F)
---------------------	---------------------------------

Mechanical specifications

Connection type	terminal compartment
Core cross-section	up to 2.5 mm ²
Housing material	PBT
Sensing face	PBT
Degree of protection	IP67

General information

Use in the hazardous area	see instruction manuals
Category	2G

Compliance with standards and directives

Standard conformity	
NAMUR	EN 60947-5-6:2000 IEC 60947-5-6:1999
Standards	EN 60947-5-2:2007 IEC 60947-5-2:2007

Approvals and certificates

UL approval	cULus Listed, General Purpose
CSA approval	cCSAus Listed, General Purpose
CCC approval	CCC approval / marking not required for products rated ≤ 36 V

Dimensions

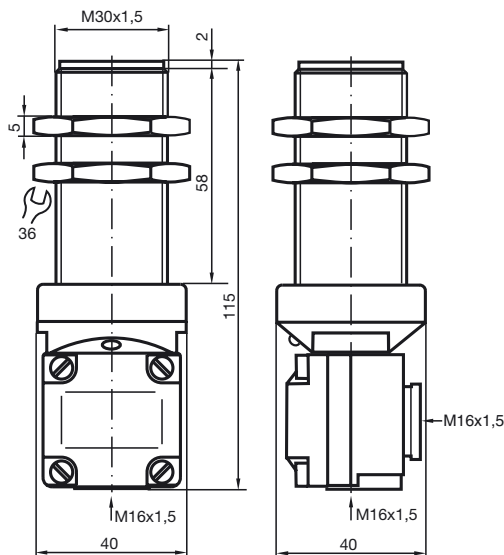

Electrical Connection

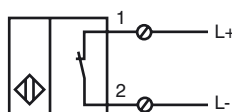

Release date: 2014-08-01 12:31 Date of issue: 2014-08-01 106475_eng.xml

ATEX 2G

Instruction

Device category 2G

EC-Type Examination Certificate

CE marking

ATEX marking

Directive conformity

Standards

Appropriate type

Effective internal capacitance C_i Effective internal inductance L_i

General

Ambient temperature

Installation, Commissioning

Maintenance

Specific conditions

Protection from mechanical danger

Manual electrical apparatus for hazardous areas

for use in hazardous areas with gas, vapour and mist

PTB 00 ATEX 2048 X

CE 0102

II 2G Ex ia IIC T6 Gb

94/9/EG

EN 60079-0:2009, EN 60079-11:2012

Ignition protection "Intrinsic safety"

Use is restricted to the following stated conditions

NJ 10-30GK...-N...

 ≤ 140 nF ; a cable length of 10 m is considered. ≤ 100 μ H ; a cable length of 10 m is considered.

The apparatus has to be operated according to the appropriate data in the data sheet and in this instruction manual. The EC-Type Examination Certificate has to be observed. The special conditions must be adhered to!

Directive 94/9/EG and hence also EC-Type Examination Certificates apply in general only to the use of electrical apparatus under atmospheric conditions.

The use in ambient temperatures of > 60 °C was tested with regard to hot surfaces by the mentioned certification authority.

If the equipment is not used under atmospheric conditions, a reduction of the permissible minimum ignition energies may have to be taken into consideration.

The temperature ranges, according to temperature class, are given in the EC-Type Examination Certificate.

Laws and/or regulations and standards governing the use or intended usage goal must be observed. The intrinsic safety is only assured in connection with an appropriate related apparatus and according to the proof of intrinsic safety.

No changes can be made to apparatus, which are operated in hazardous areas.

Repairs to these apparatus are not possible.

When used in the temperature range below -20 °C the sensor should be protected from knocks by the provision of an additional housing.