

Steckbogen-IEC 90° ; Ø50 mm ; AL  
elbow-IEC 90°

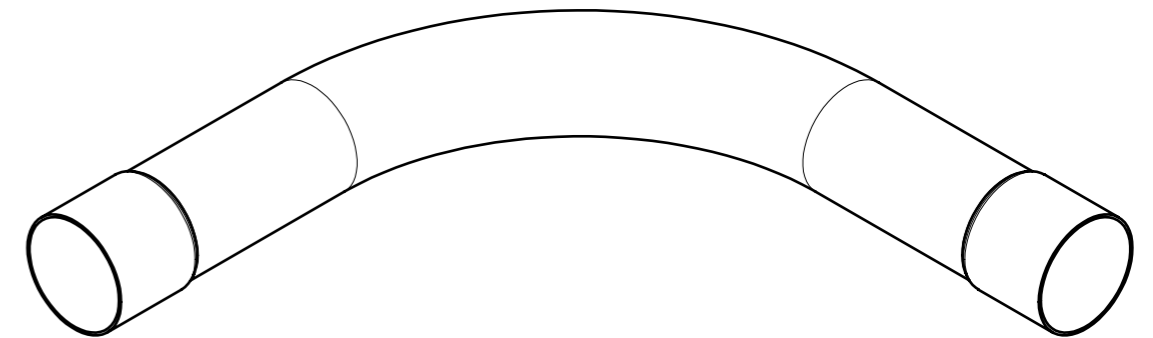
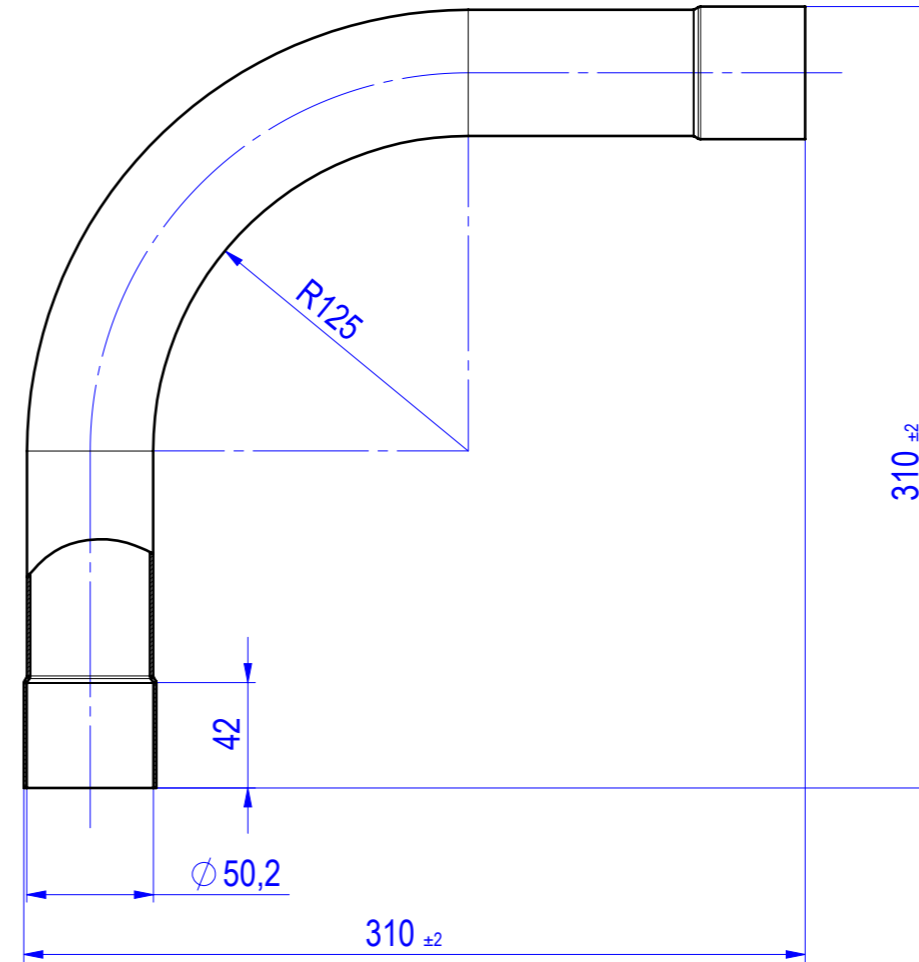
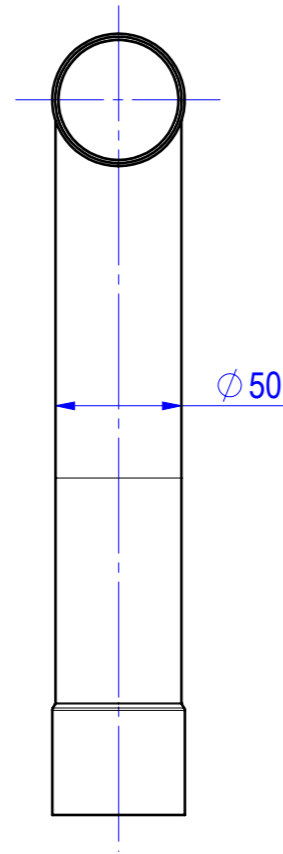

Werkstoff:  
material: Aluminium 3.3206 EN AW-6060 T5

Oberfläche:  
surface: pressblank  
mill finished

theor. Gewicht:  
theor. weight: 0,252 kg

Zur Herstellung von gesteckten 90° Eckverbindungen von zwei Steckrohren  
To produce ambitious 90° corner joints of two plain conduit

geprüft / approved:		Alle Maßangaben in [mm]	All dimensions in [mm]	Maßstab Scale
Name	Datum/Date	Benennung <b>Steckbogen-IEC 90°, Aluminium, Ø50mm</b>		
joerg-adams	20.07.2016	Title pipe elbow-IEC 90°, aluminium, Ø50mm		
gezeichnet / drawn by:		Modellnummer / Model no.		CAD-ID
Name	Datum/Date	<b>HASB50</b>		<b>IESB 50 AL</b>
volker-trings	08.09.2010			
Technische Änderungen vorbehalten / Subject to technical alteration				NX-Norm
			Niedax GmbH & Co. KG, Asbacherstraße 141 D-53545 Linz / Rhein www.niedax.de	