

IPF ELECTRONIC

Instruction Manual for ORQ8 / OTQ8 Sensors with IO-Link



Instruction Manual

ORQ8 / OTQ8 Sensors with IO-Link



Content

1	Sensors covered by this manual	3
2	IO-Link Introduction	3
2.1	SIO / DI Mode Mode	3
2.2	IO-Link Communication Mode	4
2.2.1	Cyclic data	4
2.2.2	Acyclic data	4
2.3	IO-Link Device Description (IODD)	5
2.4	Off-Line Parametrization	5
2.5	Adjustable switching sensor (AdSS)	5
3	Sensor in the IO-Link Communication Mode	6
3.1	Signal Path	6
3.2	Process Data	7
3.2.1	Process Data-In	7
3.2.2	Process Data-Out	8
4	Parameter	9
4.1	System Commands	9
4.2	Measurement Data Channel (MDC)	9
4.2.1	Measurement Values	9
4.2.2	Switch Counts	10
4.2.3	MDC Source	10
4.2.4	MDC Descriptor	10
4.3	Configuration - Switching Signal Channel (SSC)	11
4.3.1	Setpoints SP	11
4.3.2	SSC Configuration	12
4.3.3	Timefilter	15
4.3.4	Counter / SSC4	18
4.4	Signal Processing	20
4.4.1	Measurement Mode (Only OTQ8)	20
4.5	Input/Output Settings	20
4.5.1	Switching Output	20
4.6	Local User Interface	21
4.6.1	Local Teach Settings	21
4.6.2	Indication LEDs	24
4.7	Quality Parameters	25
4.8	Device Access Locks	25
5	Teach Commands	26
5.1	Teach Channel Selection, TPO & Teach Status	26
5.2	Static	27
5.2.1	Single Point Mode: 1-Point Teach	29
5.2.2	Single Point Mode: 2-Point Teach	30
5.2.3	Window Mode: Window Teach	30
5.3	Dynamic	31
5.3.1	Dynamic in Single Point Mode	31
5.3.2	Dynamic in Window Mode	32
6	Diagnosis	32
6.1	Device Status	32
6.2	Device Temperature	32
7	Glossar	33

1 Sensors covered by this manual

These instruction applies to all ORQ8 / OTQ8 sensors with IO-Link interface

2 IO-Link Introduction

IO-Link is an IO technology standardized worldwide according to IEC 61131-9. It permits manufacturer-independent digital, bidirectional point-to-point communication. For this purpose, sensors are connected to the IO-Link master via standardized 3-wire plug-in cables. IO-Link is available for various sensor technologies and can also be integrated into small miniature sensors. See also [here](#) for more information.

With the IO-Link master, which bundles several sensors, the connection to the controller is made via the respective fieldbus system. In addition, an Ethernet-based connection (with OPC UA) from the master allows direct communication from the sensor to IT systems. IO-Link masters are available as field devices for decentralized mounting or as versions for mounting in control cabinets. Many control suppliers also offer IO-Link input terminals and thus an IO-Link master implemented directly on the control. The maximum cable length between sensor and master is 20 m. However, significantly longer connections from the sensor to the controller can be realized by connecting a field master to a field bus system. This gives them maximum flexibility in the connection solution.

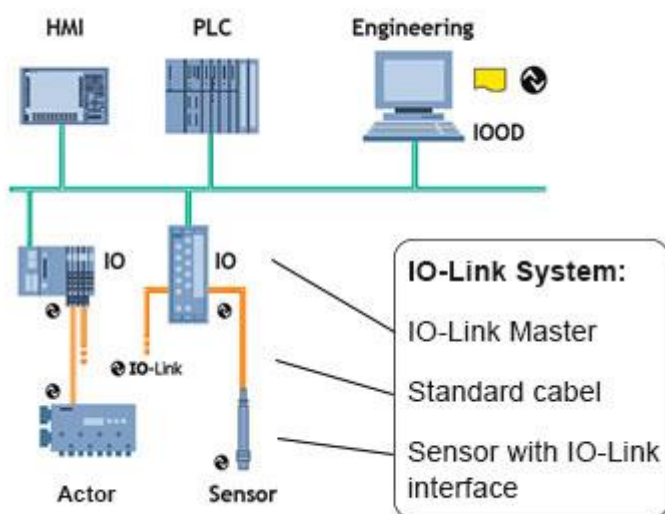

Figure 1 Example of a system architecture using IO-Link

2.1 SIO / DI Mode Mode

Each port of the IO-Link master can be operated either in SIO mode (standard in-out mode: according to the latest specification DI mode for sensors and DQ mode for actuators) or in IO-Link mode and thus process the information of all sensors. In SIO mode, the binary switching output (NPN, PNP or push-pull) of the sensor is used. In IO-Link mode, the output of the sensor (pin 4) is used as a bidirectional, digital interface to exchange measurement and diagnostic information.

2.2 IO-Link Communication Mode

The IO link communication mode is initiated by the master (PLC) with a standardized command sequence, this sequence is called “wake-up”. After successful completion of the wake-up sequence the IO link communication starts.

Data is the most important basis for process and product optimization. With the help of IO-Link, valuable additional data can be made accessible. Sensor and Master can exchange two different types of data (cyclic and acyclic data).

More information can also be found [here](#).

2.2.1 Cyclic data

Transmitted in real time. They are used for process control in the automation system. These can also be transferred to other IT systems via IO-Link.

2.2.2 Acyclic data

Through this data stream, sensors (IO devices) can be parameterized. Additionally this data stream also allows to transmit data for identification and analyzation. The figure below shows the different types of data and their value for the application.

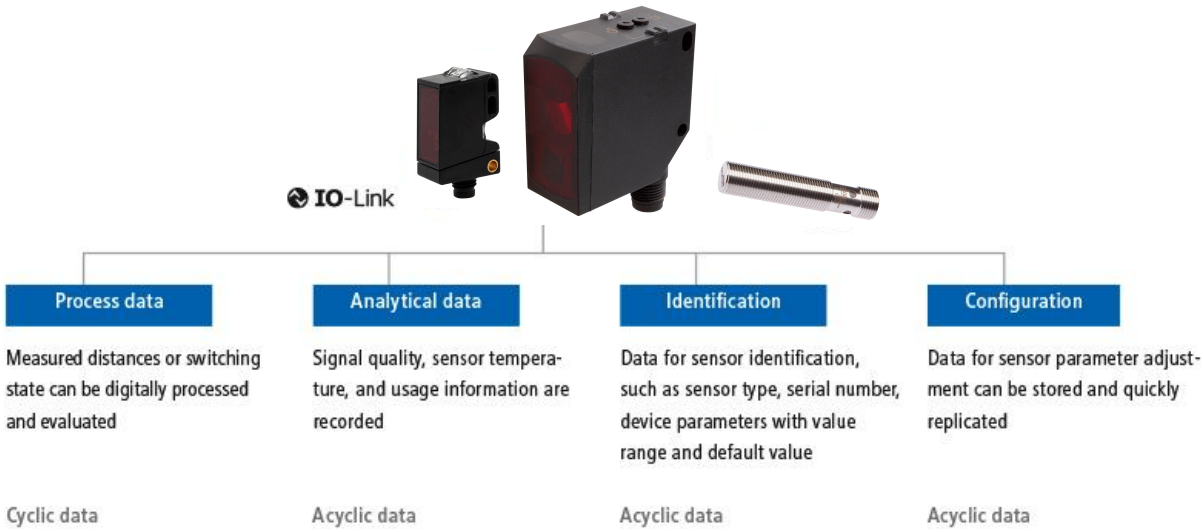

Figure 2 Different IO Link data streams

2.3 IO-Link Device Description (IODD)

Each IO-Link Device has a device description file, the so-called IODD (IO Device Description). This contains data about the manufacturer, article number, functionality, software version etc., which can be easily read out and further processed by the automation system. Each device, i.e. each sensor, can be uniquely identified both via the IODD and via an internal device ID. The identification data of the sensor also includes device or application descriptions that can be freely assigned by the user. The IODD consists of several files: a main file and optional external language files (both in XML format), as well as image files (in PNG format).

2.4 Off-Line Parametrization

Off-line sensor parameter adjustment via convenient user interfaces in the PC (via USB Master) or via Wireless App (via Wireless Master). Sensors can be conveniently configured at the desk and installed without further teach-in.

Even if IO-Link is not implemented in the machine control, sensors can be operated in SIO mode and use this advantage

2.5 Adjustable switching sensor (AdSS)

Additionally, the sensors described in this manual can be operated as “adjustable switching sensors (AdSS)” according to the Smart Sensor Profile. When treated as AdSS the sensors-Master communications happens via a fully standardized command set. Thus operation without IODD file is possible.

3 Sensor in the IO-Link Communication Mode

3.1 Signal Path

The signal path describes the rough position of a parameter in the signal processing chain. The path starts with the measuring value in the top left corner and finishes either with a physical pin (top right) or as output via the process data (bottom right).

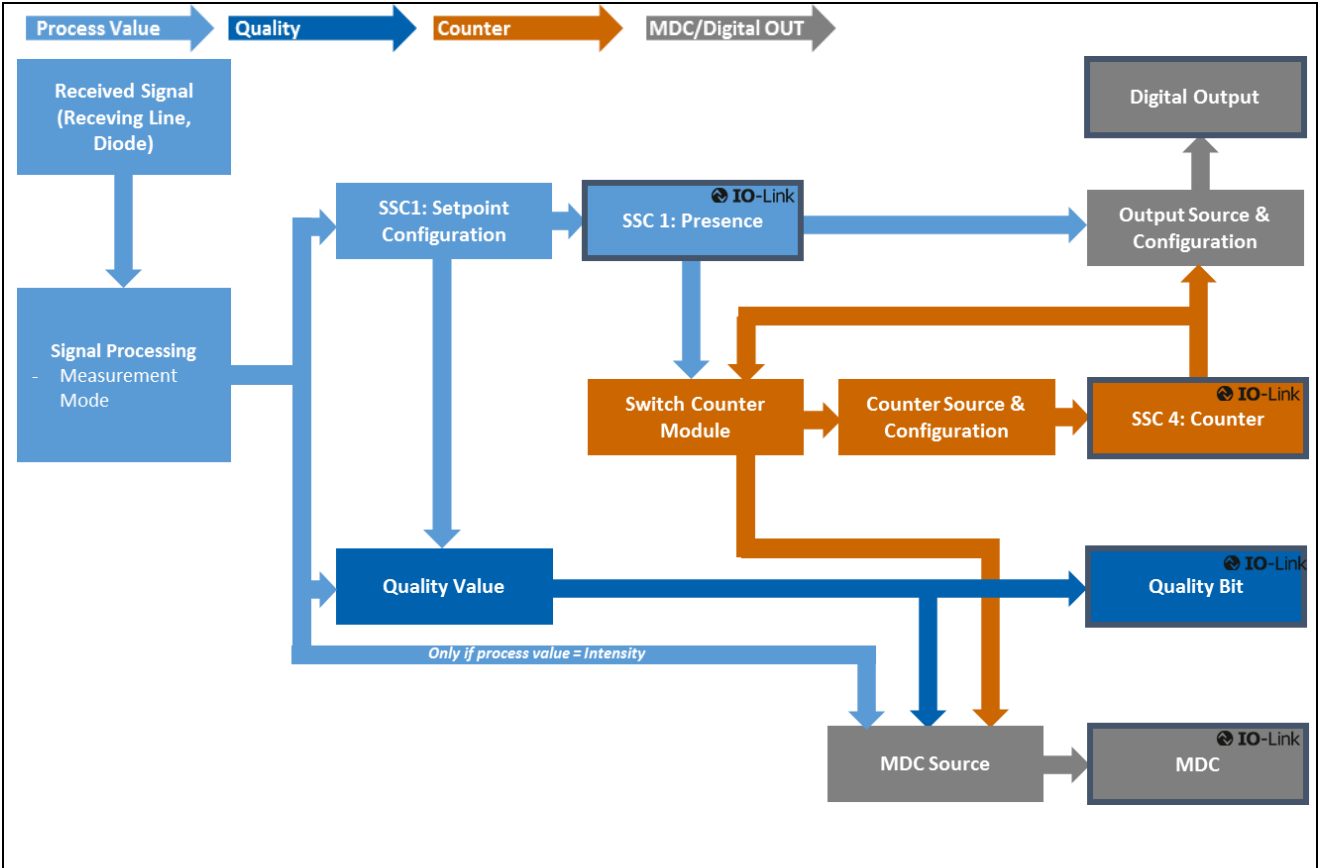

Figure 3 Illustrates the signal path from raw data to an output either through a physical pin (top right) or as output via the process data (bottom right)

3.2 Process Data

With the sensor in the IO-Link communication mode, process data is cyclically exchanged between the IO-Link master and the device. Process data is exchanged to and from the sensor (Sensor $\leftarrow\rightarrow$ Master). The master does not need to explicitly request these process data.

3.2.1 Process Data-In

Process Data-In is sent from the sensor to the master (Sensor \rightarrow Master).

IO-Link Process Data Input							
Bit:							
0	1	2	3	4	5	6	7
SSC1		Quality	Alarm		SSC4		
Bit:							
16...31							
Measurement Data Channel (MDC)							

The Process Data Input is an 32bit string and structured according to the Smart Sensor Profile definition PDI32.INT16_INT8.

Bit 0: SSC1 (Switching Signal Channel 1)

This bit is the digital representation of a switching output.

Bit 0 = 0 \rightarrow No object is being detected (Logic: Normal)

Bit 0 = 1 \rightarrow An object is being detected (Logic: Normal)

See section 4.3 to learn how to configure this bit

Bit 2: Quality

The quality bit signals that the signal quality has fallen below the configured threshold.

It is directly connected to the weak signal indication LED (section 4.6.2)

See section 4.7 to learn how to configure this bit

Bit 3: Alarm

The alarm bit indicates that there is a detectable problem with the configuration or function of the sensor.

Bit 3 = 0 \rightarrow Sensor operates properly.

Bit 3 = 1 \rightarrow A problem with either the sensor configuration or function was detected.

Bit 5: Switching Signal Channel 4 (SSC4), Switch Counter Function

By configuring SSC4, it is possible to set up a binary signal related to the number of switchcounts of SSC1.

An auto-reset and timefilters are included, to be able to create a full-featured counter being able to count lot sizes without any need to code software on the PLC.

See section 4.3.4 to learn how to configure this bit.

Bit 8 to 15: Scale

Value is the exponent to the power of ten, applicable to the value of the Measurement Data Channel (MDC)

Example:

- Value of MDC 1000
- Unit m
- Scale -6
- Means $1000 \cdot 10^{-6} \text{ m}$ or $1000 \mu\text{m}$

As ORQ8 / OTQ8 sensors only provide measuring values where no scale factor is required, the scale factor is set fixed to 0 (zero).

Bit 16 to 31: MDC / Measurement Value

MDC stands for measurement data channel. Via this channel the distance value or the switch counts of SSC1 or 4 can be read out as 16 bit integer value. See section 4.2 to learn how to configure the MDC.

3.2.2 Process Data-Out

This data is cyclically sent from the master to the sensor (Master→Sensor).

IO-Link Process Data Output							
Bit:							
7	6	5	4	3	2	1	0
						Find Me (Localization: LEDs flashing)	Disable Transmit LED

Bit 0: Disable Transmit LED

If set to true, the transmission LED is deactivated. The sensor will not deliver a measurement or switching value. This can be useful to measure neighbouring sensors sequentially or to perform functional tests.

Bit 1: Find Me Function

Signalling e.g. by flashing LEDs on the sensor to locate and physically identify a sensor in a machine or system. The signalling can be triggered, for example, from the engineering tool of the controller.

4 Parameter

4.1 System Commands

A factory reset of the sensor activates the default parameters as programmed in the factory. All parameters changed by the user will be lost.

Parameter name	Short Description	Rights	Unit / Allowed values
Standard command	Restore Factory Settings	wo	

4.2 Measurement Data Channel (MDC)

4.2.1 Measurement Values

Parameter name	Short Description	Rights	Unit / Allowed values
Measurement Value.Intensity	Intensity measuring value (Only available for ORQ8)	ro	0 ... 32000
Measurement Value.Quality Value	The quality value represents the excess gain ration in % 100 = Exactly the amount of light needed for a switching operation 200 = Twice the amount of light needed OTQ8: Quality = Strength of received light / Strength required ORQ8: Quality = Intensity value / SSC1 SP1	ro	0 ... 32000

4.2.2 Switch Counts

For each individual SSC a switching counter is implemented, which can be used as diagnosis data or also as measurement value. The number of counts of each channel can also be mapped to the measurement data channel MDC by adjusting the MDC source. Trigger of counter is on positive slope of related SSC.

Note:

Each power up, the switch counts are being reset/start from 0.

Parameter name	Short Description	Rights	Unit / Allowed values
- SSC1 Switch Counts Reset - SSC4 Switch Counts Reset	Command to set the counter value of SSCn to zero. Available for SSC1 and 4.	wo	32 Bit value
- Switch Counts.SSC1 Resettable - Switch Counts.SSC4 Resettable	Number of switching operations. Available for SSC1 and 4.	ro	32 Bit value

4.2.3 MDC Source

Selects which measuring value is mapped to the MDC channel and is then available via the process data-IN path. When SSC1, SSC2 or SSC4 is selected the number of switches detected by the channel is shown.

Parameter name	Short Description	Rights	Unit / Allowed values
MDC Selection.Source	Defines the measuring value which is mapped to the MDC channel for availability via the process data-IN path.	ro	- Intensity (Only ORQ8) - Quality Value - Switch Counter SSC1 - Switch Counter SSC4

4.2.4 MDC Descriptor

This parameter allows to read out the limits of the measuring range of the sensor and unit. When the sensor detects values outside of this range, it will report an out of range value (32760).

Parameter name	Short Description	Rights	Unit / Allowed values
MDC Descriptor.Unit Code	Shows the unit of the selected MDC source	ro	
MDC Descriptor.Lower Limit	lower limit of the measuring range	ro	
MDC Descriptor.Upper Limit	upper limit of the measuring range	ro	

4.3 Configuration - Switching Signal Channel (SSC)

The sensor features two different switching channels. Switching Signal Channel SSC1 is reserved for object detection.

Switching Channel 4 includes a counter function with an auto-reset. All switching channels can be adjusted individually via IO-Link. All switching channels can be mapped to the MDC as well. Then they will show the counts detected by the channel.

For more information about how to set-up the Counter/SSC4 channel and its behavior, please see section 4.3.4.

4.3.1 Setpoints SP

Using this parameter the user can modify the switchpoint of the sensor by enter the intensity (ORQ8) or distance value (OTQ8) at which the sensor should switch (teach-by-value function). **Figure 4** shows the illustration of the switching behavior. Regarding Single point mode only SP1 is relevant, SP2 is not active. For the Window mode SP1 & SP2 are active. The switching modes are explained in section Window mode is only available for the SSC1 of OTQ8 and for the SSC4/Counter.

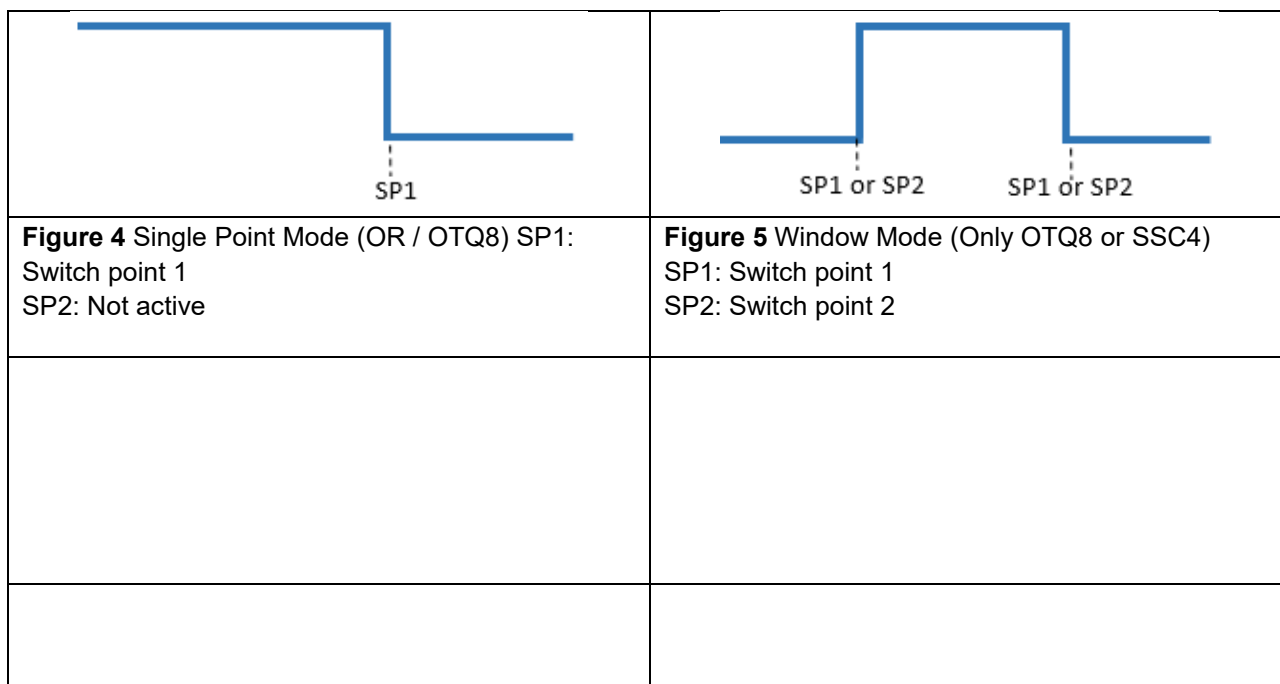

Parameter name	Short Description	Rights	Unit / Allowed values
SSC1 Param.SP1	Defines the value at which the related SSC is set to active (or inactive if inverted)	rw	
SSC1 Param.SP2 (Only OTQ8)	Defines the value at which the related SSC is set to inactive (or active if inverted) - only active if SSC is set to window mode	rw	

4.3.2 SSC Configuration

4.3.2.1 Switching Mode

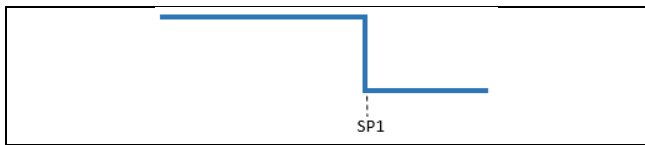
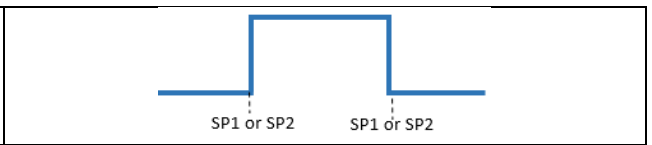
	
<p>Figure 7 Single Point Mode (OR / OTQ8)</p> <p>A single setpoint (SP1) is defined at which the sensor switches.</p>	<p>Figure 8 Window Mode (Only OTQ8)</p> <p>The sensor switches with a range defined by two different setpoints (SP1 and SP2)</p>

Parameter name	Short Description	Rights	Unit / Allowed values
SSC1 Config.Mode	Selection of the switching mode	rw	<ul style="list-style-type: none"> - Disabled - Single Point - Window (Only OTQ8)

4.3.2.2 Channel Logic

Allows to change the output logic from Normally Open (NO, Normal) to Normally closed (NC, Inverted).

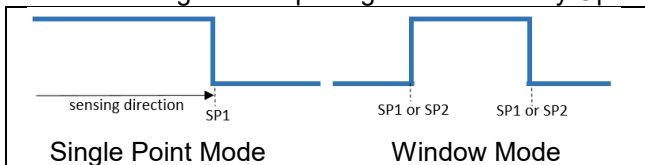
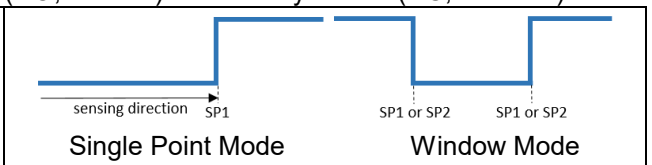
	
<p>Figure 10 «Normal» or NO setting</p> <ul style="list-style-type: none"> - The output is high, when the object is within the range defined by the setpoints. - The output is low when the object is not present or outside of the range defined by the setpoints 	<p>Figure 11 «Inverted» or NC setting</p> <ul style="list-style-type: none"> - The output is high when the object is not present or outside of the range defined by the setpoints - the output is low, when the object is within the range defined by the setpoints

Parameter name	Short Description	Rights	Unit / Allowed values
SSC1 Config.Logic	Changes the Logic from NO to NC	rw	<ul style="list-style-type: none"> - Normal (NO) - Inverted (NC)

4.3.2.3 Hysteresis Alignment Mode (Only OTQ8)

In case of axial detection tasks like stop trigger or level detection, an accurate switching distance is required. To adapt the switching behavior and the hysteresis to the movement direction of the object, the alignment of the hysteresis can be changed.

Only available for O200.G sensors.

Parameter name	Short Description	Rights	Unit / Allowed values
Hysteresis.SSC1 Alignment	Selection of the alignment modes Available for SSC1. Default: Right aligned	rw	<ul style="list-style-type: none"> - Left Aligned - Center Aligned - Right Aligned

4.3.2.3.1 Left Aligned

Left Aligned defines the hysteresis to be aligned towards the sensor / against the sensing direction.

When to apply?

- For an accurate switching distance in case the object is moving away from the sensor

Figure 12 Left Aligned, Single Point Mode	Figure 13 Left Aligned, Window Mode

4.3.2.3.2 Right Aligned

Right Aligned defines the hysteresis to be aligned away from the sensor / in sensing direction.

When to apply?

- For an accurate switching distance in case the object is moving towards the sensor.
 - o Example: Stop trigger application, usual detection tasks.

Figure 14 Right Aligned, Single Point Mode	Figure 15 Right Aligned, Window Mode

4.3.2.3.3 Center Aligned

A compromise between left and right aligned. The hysteresis is aligned symmetrical around the individual setpoints.

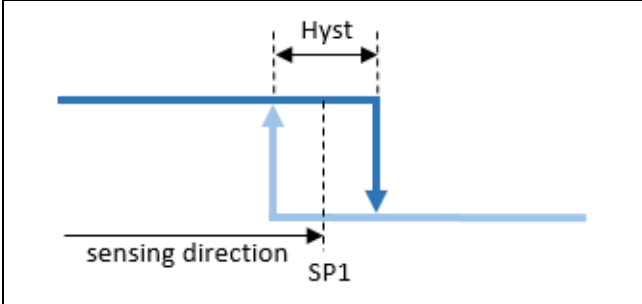

Figure 16 Center Aligned, Single Point Mode

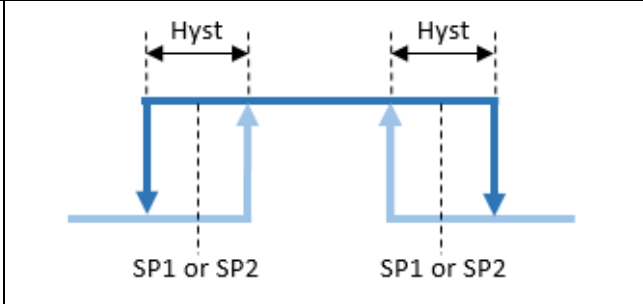

Figure 17 Center Aligned, Window Mode

4.3.3 Timefilter

This changes the timing of the switching signals, for example to avoid bouncing/suppress false switching operation. The ability to directly parametrize and configure the timing on the sensor itself, removes the need to have additional coding on the PLC or to use pulse stretching adapters.

The described time filters can be configured and applied to each SSC individually.

4.3.3.1 Response Delay Time

The response delay time defines the time, the measurement value needs to be above (single point mode) or inside (window mode) the switchpoints of the related SSC until its status changes to active (or inactive, if the logic is inverted as described in section 4.3.2.1)

When to apply?

- To avoid the detection of small peaks/false switching operations due to structure changes of the background or similar.
- To avoid wrong switching of known disturbances such as the wheel of a mixer
- To avoid bouncing.
- To optimize the timing of the execution of a subsequent actor triggered by the outssput of the sensor.

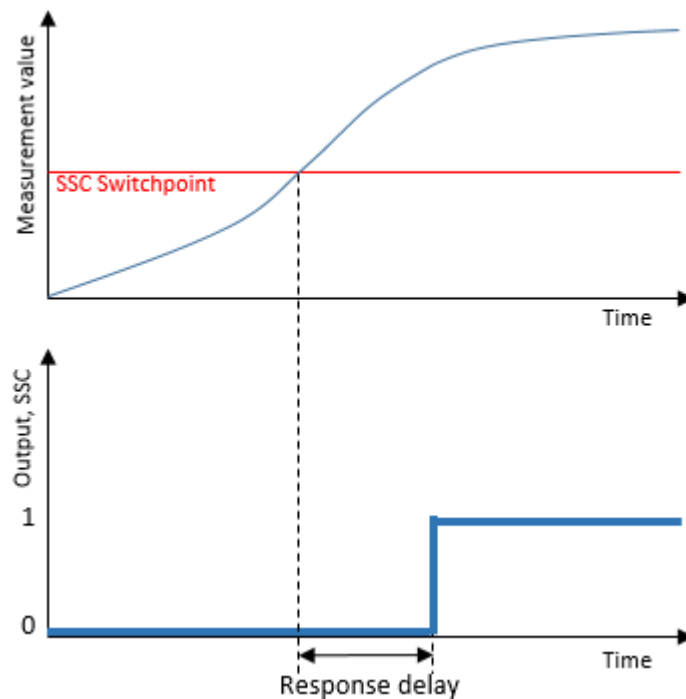

Figure 18: Response Delay

Parameter name	Short Description	Rights	Unit / Allowed values
Response Delay.SSC1 Time	Sets the response delay time, Available for SSC1 and SSC4	rw	0 to 60.000 ms

4.3.3.2 Release Delay Time

The release delay time defines the time, where the measurement value needs to be below (single point) or outside (window mode) of the switchpoints of the related SSC, until its status is changed to inactive (or active, if the logic is inverted as described in section 4.3.2.1)

When to apply?

- To avoid false switching operations in case of an object which is not 100% stable to detect over the whole length
- To suppress short losses of a proper signal due to known disturbances such as the wheel of a mixer.
- To avoid bouncing.
- To optimize the timing of the execution of a subsequent actor triggered by the output of the sensor.
- To detect a unwanted gap size within a continuous flow of products.

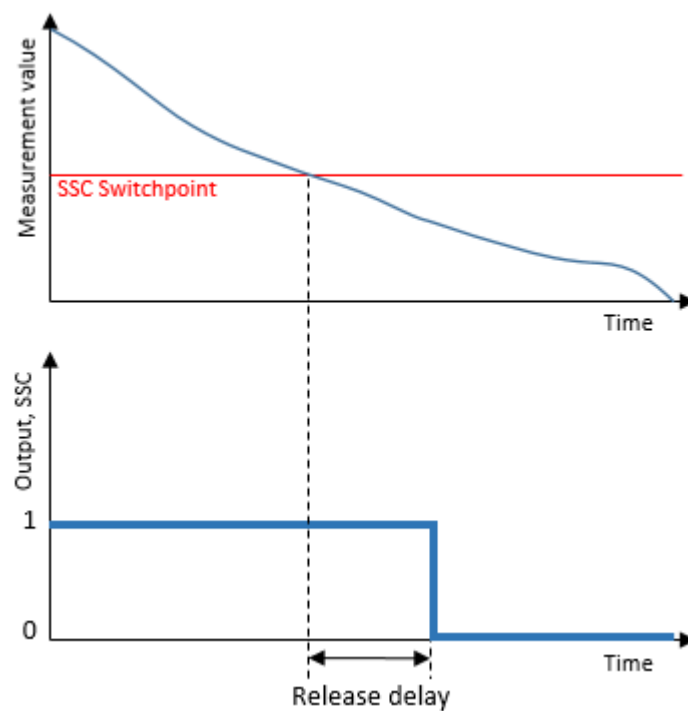

Figure 19: Release Delay

Parameter name	Short Description	Rights	Unit / Allowed values
Release Delay.SSC1 Time	Sets the release delay time, Available for SSC1 and SSC4	rw	0 to 60.000 ms

4.3.3.3 Minimum Pulse Duration

The minimum pulse duration defines the minimum time, the switching signal of the related SSC stays active or inactive after the change of its status.

When to apply?

- To align the timing of the sensor to a slower PLC.
- To avoid bouncing.
- To avoid false pulses due to short losses of a proper signal.
- To straighten the clock / pace

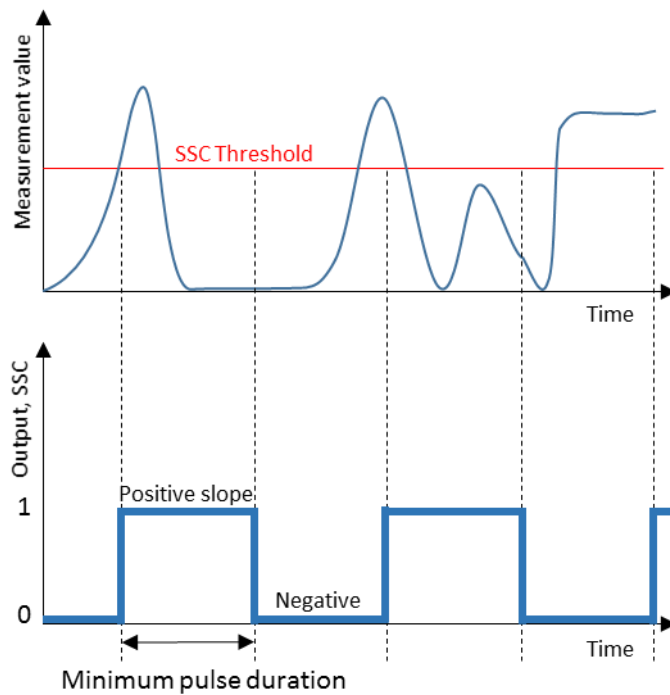

Figure 20 Minimum Pulse Duration

Parameter name	Short Description	Rights	Unit / Allowed values
Minimum Pulse Duration.SSC1 Time	Sets the response delay time, Available for SSC1 and SSC4	rw	0 to 60.000 ms

4.3.4 Counter / SSC4

For each individual SSC a switching counter is implemented, which can be used as diagnosis data or also as measurement value. The number of counts of each channel can also be mapped to the measurement data channel MDC by adjusting the MDC source (See section 4.2.3).

Trigger of counter is on positive slope of related SSC.

By configuring SSC4, it is also possible to set up a binary signal related to the number of switchcounts of SSC1. An auto-reset and timefilters are included, to be able to create a full-featured counter being able to count lot sizes without any need to code software on the PLC.

As all SSCs, SSC4 can also be mapped to the digital output giving the possibility to create a stand-alone lot-size counter.

In section 3.1, the signal path is described more detailed, to illustrate how the counter module is implemented. In section 4.3.4.2 the behavior depending on the configuration is explained.

4.3.4.1 SSC4 Configuration

In general the SSC4 offers the same features as the SSC1 and SSC2 based on distance (See 4.3.2), including also timefilters.

Exceptions:

- No hysteresis settings as there are only incremental counts.
- Additional parameters to adjust like *SSC4 Source* and *SSC4 Auto-Reset*.

Parameter name	Short Description	Rights	Unit / Allowed values
SSC4 Setpoints.SP1	Set the number of counts at which the SSC is set to active (or inactive if inverted)	rw	Counts / 0 to 32759
SSC4 Setpoints.SP2	Set the number of counts at at which the SSC is set to inactive (or active if inverted) - only active if SSC is set to window mode	rw	Counts / 0 to 32759

Parameter name	Short Description	Rights	Unit / Allowed values
SSC4 Config.Logic	Changes the Logic from NO to NC	rw	- Normal - Inverted
SSC4 Config.Mode	Selection of the switching mode	rw	- Single Point - Window
SSC4 Config.Source	Selection of source for counter function	rw	- SSC1 Switch Counter
SSC4 Config.Auto Reset	Autoreset of switch counter if given switch counts are reached. If autoreset is switched from disabled to enabled, the selected switch counter-source is automatically being reset to zero.	rw	- Enabled - Disabled

Parameter name	Short Description	Rights	Unit / Allowed values
Response Delay.SSC4 Time	Sets the response delay time, Available for SSC1, SSC2, SSC3 and SSC4	rw	0 to 60'000 ms
Release Delay.SSC4 Time	Sets the release delay time, Available for SSC1, SSC2, SSC3 and SSC4	rw	0 to 60'000 ms
Minimum Pulse Duration.SSC4 Time	Sets the response delay time, Available for SSC1, SSC2 , SSC3 and SSC4	rw	0 to 60'000 ms

4.3.4.2 SSC4 Behavior

By enabling autoreset, a full-featured counter being able to count lot sizes can be created without any need of a manual reset. Timefilters like *Response Delay* can help to optimize the timing of the execution of a subsequent actor.

Figure 21 illustrates the behavior of SSC4 using different setting. SSC4 source is hereby the switchcounter of SSC1.

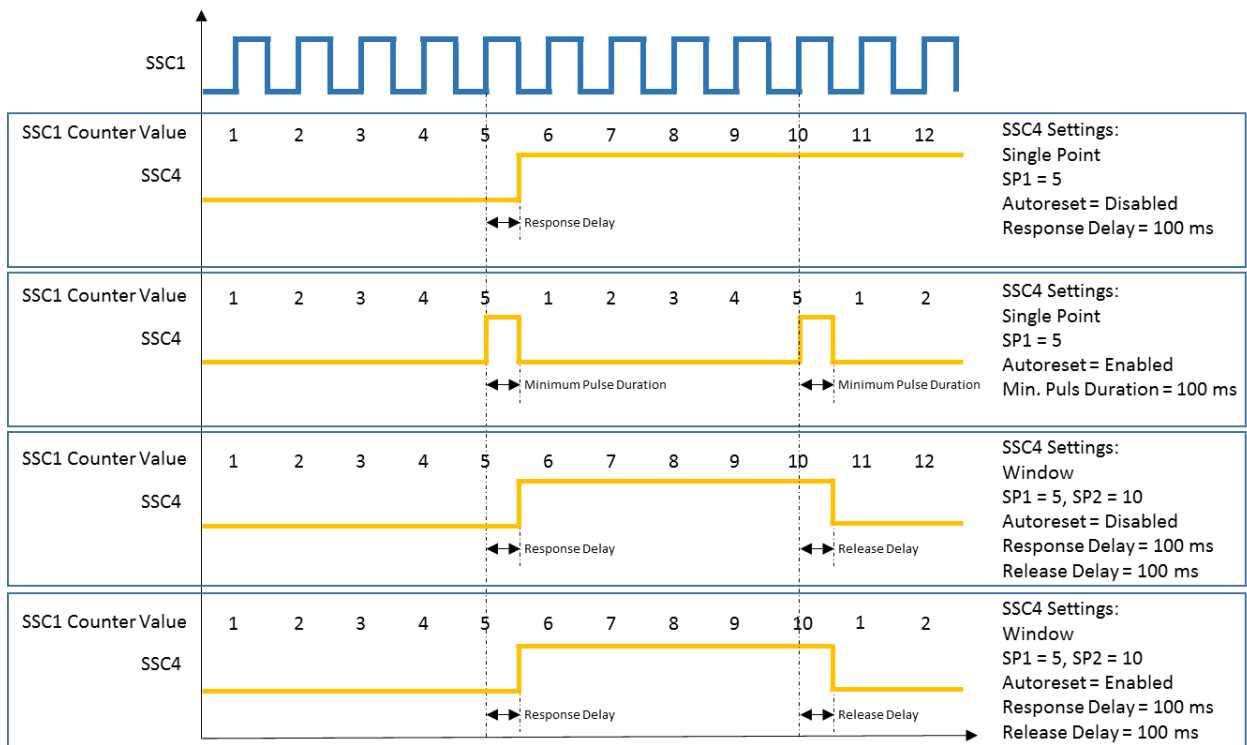

Figure 21 Behavior SSC4/Counter: Single-Point or Window, Autoreset enabled or disabled

4.4 Signal Processing

4.4.1 Measurement Mode (Only OTQ8)

With this parameter pre-defined modes can be selected to achieve optimal results without much trial and error.

Parameter name	Short Description	Rights	Unit / Allowed values
Measurement Mode	Choose measurement mode for different applications	rw	- High Speed - Standard - High Power

High Speed:

Ideal for fast moving objects. Sensors is adjusted for fastest response time. Detection ability identical to Standard-Mode but with reduced ambient light immunity

Standard:

Standard setting with outstanding performance with the highest ambient light immunity.

High Power:

Twice the excess gain compared to Standard mode but with slower response time.
Reduced hysteresis due to better signal/noise ratio.

4.5 Input/Output Settings

4.5.1 Switching Output

Parameter name	Short Description	Rights	Unit / Allowed values
DI/DO Settings.OUT1 Circuit	Selection of circuit type	rw	- PushPull (default)
DI/DO Settings.OUT1 Mode	Selection of output source (Default: SSC1)	rw	- None (SIO deactivated) - SSC1 (default) - SSC4

4.6 Local User Interface

Different parameters are available to configure the local user interface which means the indication LED and the qTeach availability or qTeach mode (Xpress vs Xpert, static vs dynamic)

4.6.1 Local Teach Settings

Parameter name	Short Description	Rights	Unit / Allowed values
Teach Lock Settings.Teach Lock Time This parameter is only applicable for the qTeach – the teach-in by wire is not affected / locked at any time.	Defines the time between power up and qTeach deactivation. 0: qTeach never locked 1 – 120 min: Accepted range 0xFF: qTeach always locked Default: 5 min	rw	0 ... 120 min 0xFF
Teach Mode Settings.Teach Mode	Defines the teach mode for the qTeach and teach by wire.	rw	Xpert Static Xpress Static Xpert Dynamic Xpress Dynamic

4.6.1.1 Local Teach: Teach Modes

Applicable for qTeach and for teach-in by wire

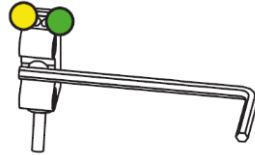

Figure 22: Teach-in activation by qTeach

The switching behavior depends if the switching mode is set to single point or window (only available for OTQ8).

For the behavior resulting based on the teach-in, please check section 5 and the following sub-chapters or section 4.3.2 how to adjust the switching mode or relevant parameters. (TPO, hysteresis, ...)

If the teach-in was not successful, is indicated by the LED flashing 8 Hz for 2 sec. Previous settings are restored.

If the teach-in was successful, the sensor turns in to operation mode.

Mode	Level 1	Level 2
Xpert Static	1 Point Teach Enter teach level by activating qTeach-in >2 .. <4 sec (Green LED flashes with 2 Hz) Tap qTeach to teach-in the position	2-Point Teach Enter teach level by activating qTeach >4 ... <6 sec. (Yellow LED flashes with 2 Hz) Tap qTeach to teach the position of TP1 Tap qTeach again to teach the position of TP2
Xpert Dynamic	Start: Enter teach Level by activating qTeach >2 .. <4 sec. (Green LED flashes with 2 Hz) Data acquisition starts after releasing teach-in Stop: Tap qTeach Accepted duration: 2 ... 15 sec	N/A
Xpress Static One Step Teach	Activate qTeach for >2 sec to teach-in the position (Green LED flashes with 2 Hz)	N/A
Xpress Dynamic One Step Teach	Start: Activate qTeach Stop: Release qTeach (Green LED flashes with 2 Hz) Accepted duration: 2 ... 15 sec	N/A

Mode	Level 3: Output Logic	Level 4: Factory Reset
Xpert Static	Enter teach Level by activating qTeach >6 .. <8 sec. (Green & yellow LED flash with 2 Hz) Tap qTeach to change the logic indicated by the LEDs Green LED: Normal Yellow LED: Inverted	Enter teach level by activating qTeach >8 ... <12 sec. No further actions required
Xpert Dynamic	Enter teach Level by activating qTeach >6 .. <8 sec. (Green & yellow LED flash with 2 Hz) Tap qTeach to change the logic indicated by the LEDs Green LED: Normal Yellow LED: Inverted	Enter teach level by activating qTeach >8 ... <12 sec. No further actions required
Xpress Static One Step Teach	N/A	N/A
Xpress Dynamic One Step Teach	N/A	N/A

4.6.2 Indication LEDs

While the underlying functionality of the LEDs is in general well defined, it is possible to deactivate or to invert those.

LED Indication	Legend	Operating Mode																		
	<ul style="list-style-type: none"> ● LED on ① LED flashing 1 Hz ② LED flashing 2 Hz ⑧ LED flashing 8 Hz 	EN																		
		<table border="1"> <thead> <tr> <th>LED Indicators</th> <th>Green</th> <th>Yellow</th> </tr> </thead> <tbody> <tr> <td>Power on</td> <td style="text-align: center;">●</td> <td></td> </tr> <tr> <td>Short circuit</td> <td style="text-align: center;">①</td> <td></td> </tr> <tr> <td>Output 1 active</td> <td></td> <td style="text-align: center;">●</td> </tr> <tr> <td>Output 1 signal close to threshold</td> <td></td> <td style="text-align: center;">⑧</td> </tr> <tr> <td>Teach-in mode</td> <td colspan="2" style="text-align: center;">see Teach-in Instruction</td> </tr> </tbody> </table>	LED Indicators	Green	Yellow	Power on	●		Short circuit	①		Output 1 active		●	Output 1 signal close to threshold		⑧	Teach-in mode	see Teach-in Instruction	
	LED Indicators	Green	Yellow																	
	Power on	●																		
	Short circuit	①																		
Output 1 active		●																		
Output 1 signal close to threshold		⑧																		
Teach-in mode	see Teach-in Instruction																			

Figure 23 LED Indication - Standard-behavior in operating mode

Parameter name	Short Description	Rights	Unit / Allowed values
LED Settings.Green Mode	Power on/short circuit	rw	On Off
LED Settings.Yellow Mode	Connected to output 1 - State - Signal close to threshold/weak signal The weak signal can be configured by using the quality bit (section 4.7) Default: LED on if output is active	rw	On Off Inverted

If the LED mode is set

- *On*, the behaviour of the related LED is as described in Figure 23.
- *Off*, the LED is deactivated except if the function Find Me is activated. (See section 3.2.2)
- *Inverted*, the LED behaviour is inverted to the definition in Figure 23.

4.7 Quality Parameters

The ORQ8 / OTQ8 sensors offers quality values to give an idea about the reliability or trend of the process based on the ratio of the current signal and the threshold or minimum required signal.

- Contamination indicaton
- Alignment indication
- Evaluation of process reliability

Parameter name	Short Description	Rights	Unit / Allowed values
Quality Value	<p>Same value as described in section 4.2.1.</p> <p>The quality value represents the excess gain ration in %</p> <p>100 = Exactly the amount of light needed for a switching operation 200 = Twice the amount of light needed</p> <p>OTQ8: Quality = Strength of received light / Strength required</p> <p>ORQ8: Quality = Intensity value / SSC1 SP1</p>	ro	
Quality Bit Threshold	<p>Sets the threshold for the quality bit value in % which is mapped to the process data in (section 3.2.1)</p> <p>The quality bit is directly connected to the weak signal indication LED (section 4.6.2)</p> <p>Default: 150</p>	rw	

4.8 Device Access Locks

Parameter name	Short Description	Rights	Unit / Allowed values
Parameter (write) Access Lock	n/a	rw	True/False
Data Storage Lock	Deactivates the parameter server functionality / does not overtake values	rw	True/False
Parametrization Lock	n/a	rw	True/False
Local User Interface Lock	n/a	rw	True/False

5 Teach Commands

By using teach commands, the setpoints of the switching signal channel SSC1 can be defined by teach-in the position of the object or reference.

Next to teach-by-value which can be applied as described in section 4.3.1, using teach commands makes it easy to compensate individual variations such as mechanical and mounting tolerances.

There are two different procedures available – static or dynamic – which can be individually chosen independent of the switching mode of the selected SSC

- Static: Defines the setpoints by teach-in the positions of non-moving objects
- Dynamic: For moving and small objects. Analyzes the minimum and maximum distances within a time frame to define the setpoints.

The teach-in procedures are described more detailed in section 5.2 (Static) and 5.3 (Dynamic).

The switching behavior of each switching signal channel depends on the configuration (Switching Mode, Channel Logic, ...) described in section 4.3.2.

5.1 Teach Channel Selection, TPO & Teach Status

The described teach commands can be applied to individual switching signal channels. Before proceeding with the teach-in procedure, make sure to select the SSC that should be addressed.

Furthermore different information are available to indicate the current mode and teach-in state of the selected switching signal channel to help to execute the right commands described in section 5.2 and 5.3.

Parameter name	Short Description	Rights	Unit / Allowed values
TI.Select	Selects the SSC to which the teach-in will be applied	rw	SSC1
Teach Point Offset.TPO [%]	Defines the offset used for the calculation of the setpoints. Affects the teach-in by IO-Link or qTeach/bywire. See the following chapters regarding the behaviour depending on the teach-modes		%
Teach Status.Teach Flag SP1 TP1	If Teach SP1 or Teach SP1 TP1 was performed, this flag is set to Taught	ro	Not Taught / Taught
Teach Status.Teach Flag SP1 TP2	If Teach SP1 or Teach SP1 TP2 was performed, this flag is set to Taught	ro	Not Taught / Taught
Teach Status.Teach Flag SP2 TP1	Only available for OTQ8	ro	Not Taught / Taught
Teach Status.Teach State	Default: Idle	ro	0 = Idle 1 = SP1 Success 2 = SP2 Success 3 = SP1&2 Success 4 = Waiting for Command 6 = Busy 7 = Error

5.2 Static

By using teach commands, setpoint 1 and setpoint 2 (SP1 and SP2) can be set by placing the object at the desired position and triggering the command. Which command is used in which order varies depending on the active switching mode (Single-Point or Window) of the selected-teach channel and is explained in the following sections.

Switching Mode	Teach Mode	Applicable for	Result
Single Point	1-Point Teach	All	<p>Defines SP1 by teach-in only one position and adding a configurable offset to this position/value.</p> <p>OTQ8: Teaches the position of the object $SP1 = TP + TPO$</p> <p>ORQ8: Teaches the sensor hitting the reflector without any object in between. $SP1 = TP * TPO$</p>
Single Point	2-Point Teach	OTQ8 ORQ8	<p>Defines SP1 based on TP1 and TP2 for an optimized switching behaviour.</p> <p>OTQ8: Teaches the position of the object and of the background. $SP1 = (TP1 + TP2) / 2$</p> <p>ORQ8: Teaches the sensor hitting the reflector with and without an object in between $SP1 = \text{sqrt}(TP1 * TP2)$</p>
Window	Window Teach	OTQ8	Defines a window based on two positions

Parameter name	Short Description	Rights	Unit / Allowed values
Teach SP1	<p>Sets SP1 at the current position of the object which is within the allowed range.</p> <p>In singlepoint mode, the teachpoint offset TPO needs to be considered.</p>	wo	
Teach SP2	<p>Sets SP2 at the current position of the object which is within the allowed range.</p> <p>In singlepoint mode, the teachpoint offset TPO needs to be considered.</p>	wo	
Teach SP1 TP1	Command can be used to define SP1 based on TP1 and TP2	wo	
Teach SP1 TP2	Command can be used to define SP1 based on TP1 and TP2	wo	
Teach Apply	Stores the teached in SP and sets the Teach State to idle	wo	
Teach Cancel	Aborts the on-going teach-in process	wo	

5.2.1 Single Point Mode: 1-Point Teach

If the selected SSC is configured as Single Point mode (Section 4.3.2.1), following command sequence is required to teach-in SP1:

Command sequence:

- Place object (OTQ8), reflector (ORQ8) at desired position
- Execute *Teach SP1* to teach-in the position
- Execute *Teach Apply* to store the resulting setpoint

By executing *Teach Cancel* the teach-in procedure can be canceled at any state, as long *Teach Apply* has not been used before.

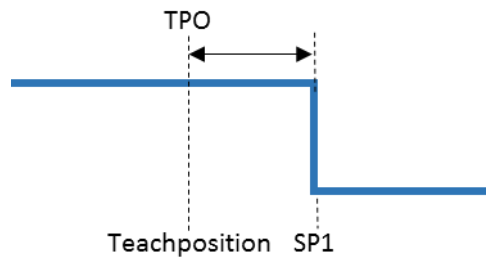

Figure 24: Single Point Teach, switching behavior

Figure 24 shows the switching behavior of the selected SSC if the teach-in was successful. In single point mode, the TPO/Teach Point Offset will be added on the teached-in value to define the setpoint.

OTQ8: $SP1 = TP + TPO$
ORQ8: $SP1 = TP * TPO$

5.2.2 Single Point Mode: 2-Point Teach

Defines SP1 based on TP1 and TP2 for an optimized switching behaviour.

OTQ8: Teaches the position of the object and of the background.

ORQ8:

Teaches the sensor hitting the reflector with and without an object in between

Command sequence:

- Place object at desired switching distance
- Execute *Teach SP1 TP1* to teach TP1
- Execute *Teach SP2 TP2* to teach TP2
- Execute *Teach Apply* to store the setpoint

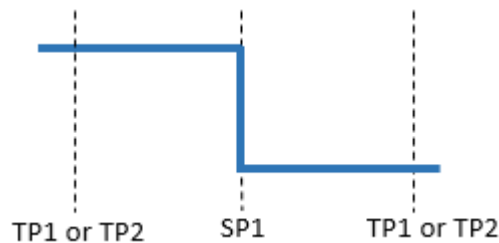

Figure 26: 2-Point Teach, switching behavior

OTQ8: $SP1 = (TP1 + TP2) / 2$

ORQ8: $SP1 = \sqrt{TP1 * TP2}$

5.2.3 Window Mode: Window Teach (Only OTQ8)

If the selected SSC is configured to Window mode (Section 4.3.2.1), following command sequence can be applied to teach-in SP1 and SP2:

Command sequence:

- Place object at desired switching distance
- Execute *Teach SP1* to teach-in the distance related to SP1
- Execute *Teach SP2* to teach-in the distance related to SP2
- Execute *Teach Apply* to store the setpoint

By executing *Teach Cancel* the teach-in procedure can be canceled at any state as long *Teach Apply* has not been used before.



Figure 27: Window Teach, switching behavior

Which SP was taught at a higher distance does not have any influence on the switching behavior ($SP1 < SP2$, $SP1 > SP2$).

5.3 Dynamic

By using the dynamic teach-in commands, it is possible to define the setpoints by evaluating the minimum and maximum measurement values within a time frame. Accepted duration: 2 ... 15 sec.

When to apply?

- For moving and/or small objects

The command sequence to perform a dynamic teach-in is the same for all switching modes.

Command sequence:

- Execute *Dynamic Teach Start* to start the data acquisition
- Execute *Dynamic Teach Stop* to stop the data acquisition
- Execute *Teach Apply* to store the setpoint

By executing *Teach Cancel* the teach-in procedure can be canceled at any state as long *Teach Apply* has not been used.

Parameter name	Short Description	Rights	Unit / Allowed values
Dynamic Teach SP Start	Starts the data acquisition.	wo	
Dynamic Teach SP Stop	Stops the data acquisition	wo	
Teach Apply		wo	
Teach Cancel		wo	

5.3.1 Dynamic in Single Point Mode

If the selected SSC is configured to Single Point mode (Section 4.3.2.1), during the dynamic teach-in the minimum and maximum values are evaluated and the setpoint SP1 set to the middle

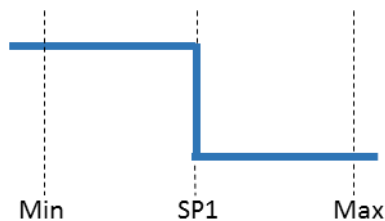

Figure 28: Dynamic Single Point Teach, switching behavior

OTQ8: $SP1 = (Min + Max) / 2$

ORQ8: $SP1 = \sqrt{Min * Max}$

5.3.2 Dynamic in Window Mode (Only OTQ8)

If the selected SSC is configured to Window mode (Section 4.3.2.1) during the dynamic teach-in the minimum and maximum values are evaluated. Setpoint SP1 is set to Min, SP2 is set to Max.

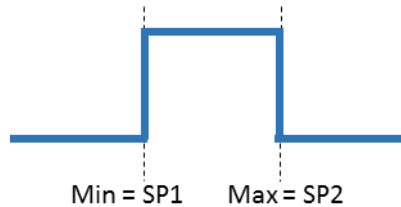

Figure 29: Dynamic Window Teach, switching behavior

6 Diagnosis

In addition to solving the primary application, the simple evaluation of secondary data, such as temperature, supply voltage or operating time, allows for predictive maintenance and thus optimum machine availability.

6.1 Device Status

Parameter name	Short Description	Rights	Unit / Allowed values
Device Status	Indicates if the sensor is working properly	ro	0=Device is OK 2=Out of Specification 4=Failure
Detailed Device Status		ro	

6.2 Device Temperature

An integrated temperature sensor allows to track the internal temperature of the sensor.

Please be aware that compared to the ambient temperature the indicated values are higher due to the internal heating of the sensor.

The temperature may also vary due to mounting conditions and due to the electric load connected to the output.

Parameter name	Short Description	Rights	Unit / Allowed values
Device Temperature.Current		ro	
Unit Selection.Temperature	Choice of temperature unit (Default: °C)	rw	°C, °F, K

7 Glossar

wo	Write only access
rw	Read and write access
ro	Read only access
SSC	Switching Signal Channel
MDC	Measurement Data Channel
SP	Switching Point
AdSS	Adjustable switching sensor

