

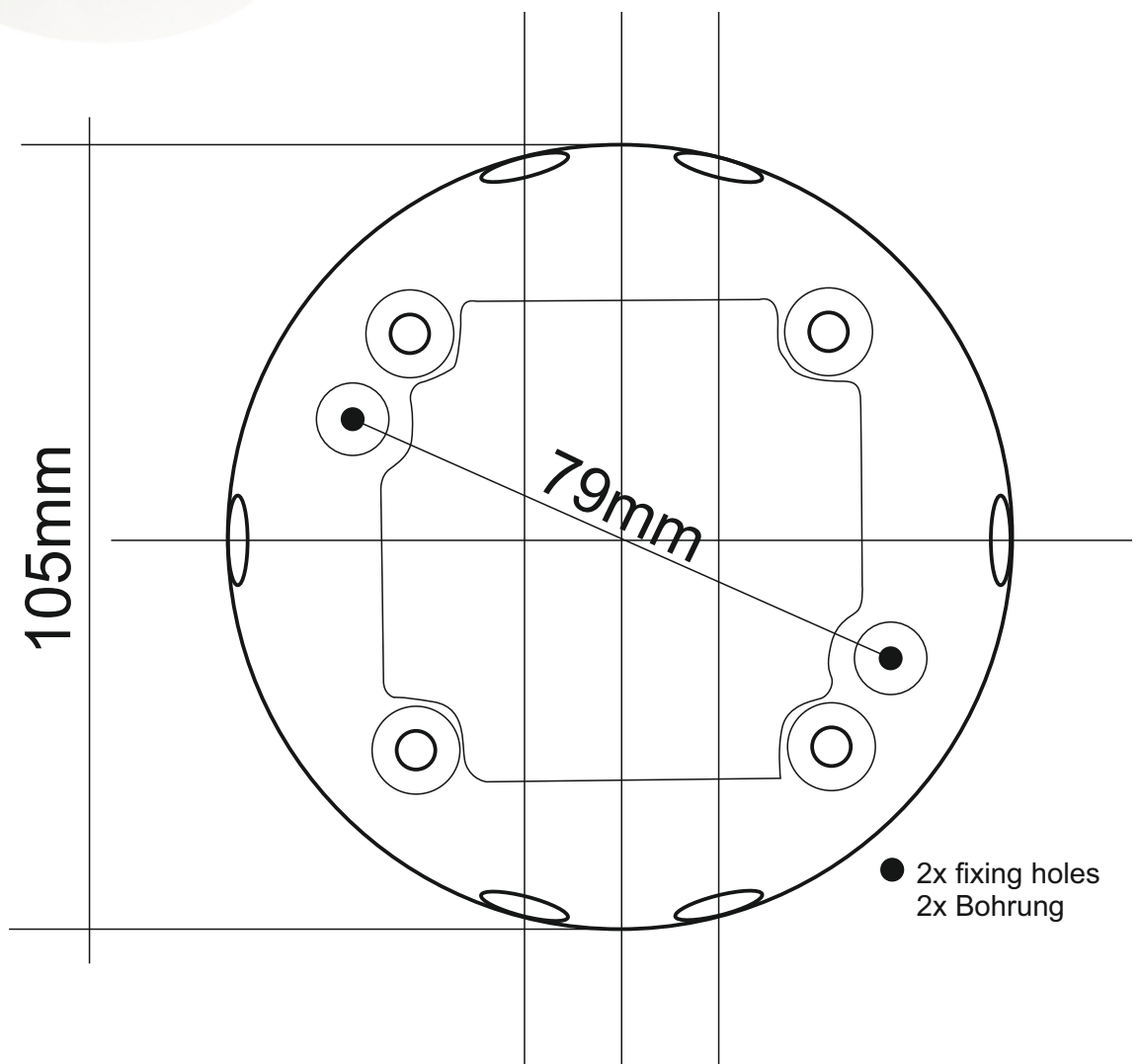



Drilling pattern for surface mount frame 25420

Bohrschablone für AP-Rahmen Art. 25420



 Hinweis: Nicht skalieren, sondern in «Tatsächliche Grösse» drucken!

 Remarque: ne pas redimensionner, mais imprimer en «grandeur réelle»!

 N.B.: Do not resize! Always print at "actual size".