

Inhalt

- 1. Bestimmungsgemäße Verwendung2
- 2. Sicherheitshinweise2
- 3. Elektrischer Anschluss Basis- Abschlussmodul.....3
 - 3.1 BR 50-BC mit Anschlusskabel3
 - 3.2 Anschluss mit M12-Stecker3
- 4. Zusammenbau4
 - 4.1 Leuchtmittel einsetzen/ austauschen.....4
 - 4.2 Module zusammenbauen4
- 5. Funktionsmodule:.....5
 - 5.1 Easy Module.....5
 - 5.2 Flexi Module5
 - 5.3 Überwachtes LED-Modul - BR 50-LED-M6
 - 5.4 Schallgebermodul BR 50-SM7
 - 5.5 Schallgebermodul BR 50-SM HO8
 - 5.6 AS-i-Modul.....9
- 6. Montagemöglichkeiten10
- 7. Technische Daten.....11
 - 7.1 Allgemein.....11
 - 7.2 Elektrische Daten11
 - 7.3 Abmessungen.....12
- 8. Zubehör.....13
- 9. Wartung, Service, Instandhaltung14
- 10. Außerbetriebnahme, Demontage und Entsorgung.....14

Schutzvermerk nach DIN ISO 16016 beachten!

Originalsprache

1. Bestimmungsgemäße Verwendung





Signalsäulen der Intense-Serie BR 50 dienen der Signalisierung von z.B. Gefahr-/ Zustandsanzeigen in Industrie, Gewerbe- und Gebäudebereichen.

Die verschiedenen Funktionsmodule bieten unterschiedliche Möglichkeiten der Signalisierung wie Dauerlicht, Blinklicht oder XENON-Blitzlicht.

Die Nutzung des Schallgebers BR 50-SM HO bietet außerdem eine zusätzliche akustische Alarmierung.

Die Geräte sind für den Einsatz im Innen- und Außenbereich geeignet und nur für die ortsfeste Montage bestimmt.

2. Sicherheitshinweise

	<p>GEFAHR - Lebensgefahr durch Stromschlag Spannungsführende Geräte und freiliegende Anschlussleitungen können Stromschläge erzeugen und schwere Unfälle verursachen.</p> <ul style="list-style-type: none"> - Arbeiten an elektrischen Anschlüssen dürfen nur elektrotechnisch geschulte und autorisierte Fachkräfte durchführen. - Vor der Montage alle Zuleitungen spannungsfrei schalten und gegen Wiedereinschalten sichern. Spannungsfreiheit immer sicherstellen. - BR 50-FL: Entladungsphase von 2 Minuten für die elektrischen Komponenten abwarten. Erst danach Gerät öffnen. - Das Anlegen der Betriebsspannung darf nur bei fest verschlossenem Gehäuse erfolgen.
	<p>WARNUNG - Gefahr durch unzulässigen Einsatz der Geräte</p> <ul style="list-style-type: none"> - Der nicht bestimmungsgemäße Einsatz kann zu schweren Unfällen führen. - Die Geräte nur in unbeschädigtem Zustand innerhalb der spezifizierten Kenndaten betreiben. - Die Funktion des Gerätes ist nur gewährleistet, wenn die Funktionsmodule korrekt zusammengefügt sind. - Die Geräte sind nur für die ortsfeste Montage bestimmt.
	<p>GEFAHR - Gefahr durch Beschädigung der Geräte</p> <ul style="list-style-type: none"> - Bei Installation und Wartung der Geräte immer die Angaben auf dem Typenschild beachten.
	<p>VORSICHT - Verletzungsgefahr durch scharfe Kanten oder erhitzte Bauteile</p> <ul style="list-style-type: none"> - Bei Installations-, Montage-, oder Service-/ Wartungsarbeiten geeignete Persönliche Schutzausrüstung (PSA) tragen. - Verdrahtung entfernt von scharfen Kanten, Ecken und internen Komponenten vornehmen, Kollisionen mit Bauteilen vermeiden.
	<p>VORSICHT – Beeinträchtigung des Sehvermögens</p> <ul style="list-style-type: none"> - Um eine Beeinträchtigung des Sehvermögens zu verhindern, den dauernden, direkten Blick in die aktivierte Leuchte vermeiden. - BR 50-FL: Unvermittelte Blitzauslösung kann zu Schreckreaktionen führen.

3. Elektrischer Anschluss Basis- Abschlussmodul

3.1 BR 50-BC mit Anschlusskabel

12 – 230 V
Kabelanschluss:
Drehmoment 0,6 Nm

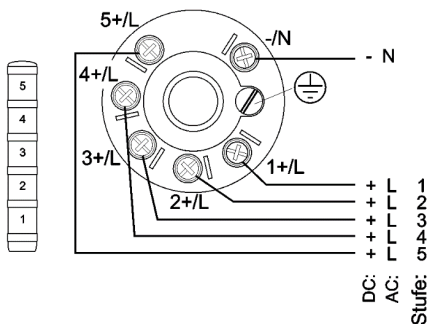

Ø Zuleitung max. 1,5 mm²
Aderendhülse 8mm

Erdungsanschluss
Drehmoment 0,6 Nm

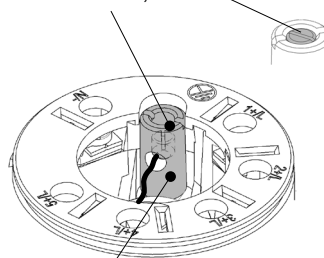

Bei Rohr- oder Stativmontage (Option):
Äußere Schraube lösen, Rohr montieren und Schraube wieder festziehen
Drehmoment: 1,5 Nm

115/ 230V AC bei Stativ- oder Rohrmontage:
Elektrischen Anschluss mit einer Mantelleitung ausführen.

BR 50-BC

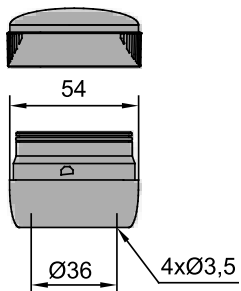

P/N: 28250010000

3.2 Anschluss mit M12-Stecker

12 – 24 V AC/DC

BR 50-BC-M12

BR 50-BC-Sxxx-M12

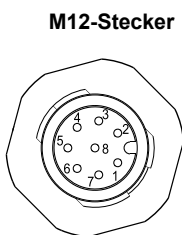

M12-Stecker	Anschluss BR 50- Stufe...
1	1 / +
2	2 / +
3	3 / +
4	4 / +
5	5 / +
6	/
7	- (COM)
8	/

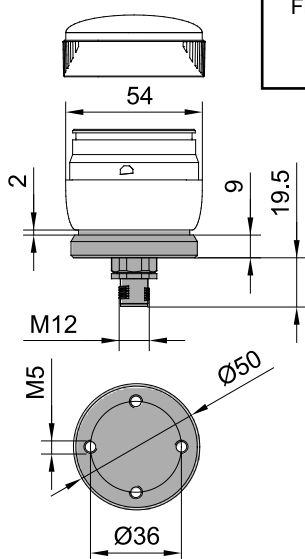

P/N: 28250126000

Flächendichtung im
Lieferumfang
enthalten.

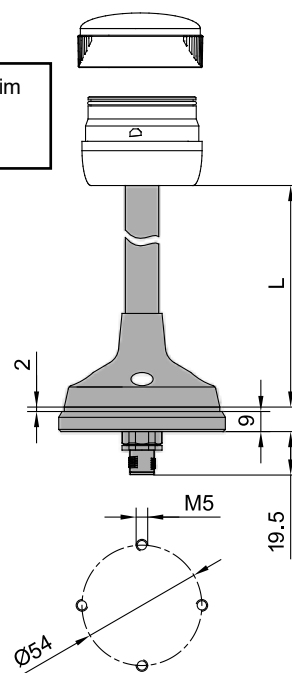

P/N: 28250126010 97,5
P/N: 28250126020 237,5
P/N: 28250126040 387,5
L [mm]

4. Zusammenbau

4.1 Leuchtmittel einsetzen/ austauschen

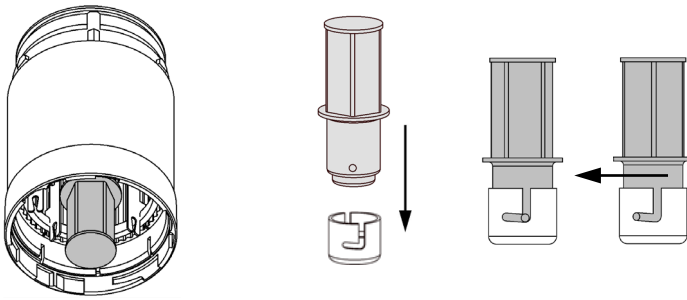

Zur einfacheren Handhabung beim Tauschen eines Leuchtmittels kann das Flexi-Tool als Zubehör verwendet werden, siehe [Flexi Tool](#).

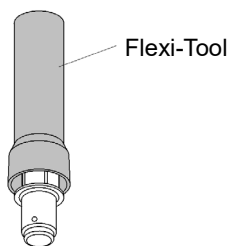

4.2 Module zusammenbauen

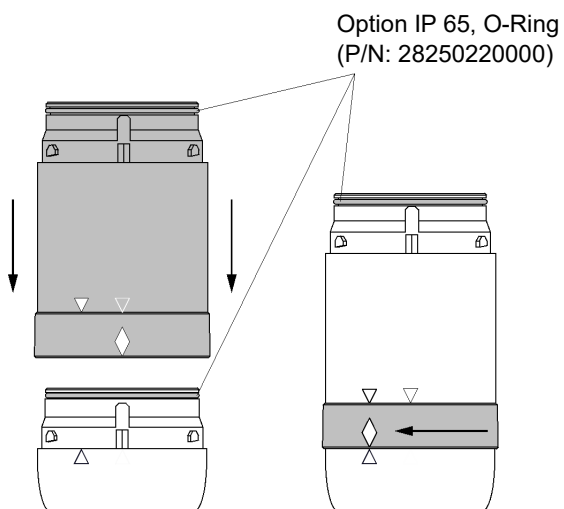

Einbau O-Ring IP 65 (P/N: 28250230000)
für Stativ- oder Rohrmontage

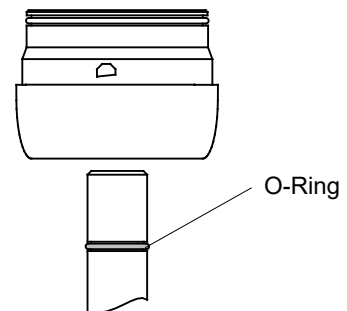

5. Funktionsmodule:

5.1 Easy Module

Das Modul ist bestückt mit schon montierter Lichtquelle.

Fully Coloured Module

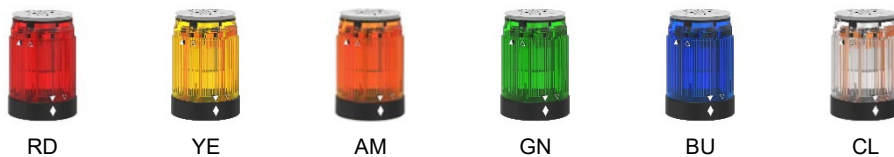

		Spannung		
Farbiges Modul P/N: 2825037*	bestückt mit LED-Einsatz (Dauerlicht) LED-Farben: weiß, rot, gelb, grün	24V AC/ DC	230V AC	115V AC
		Daten siehe 7.2 Elektrische Daten		
Farbiges Modul P/N: 2825007xx#0 xx: 10=230V AC, 16=115V AC, 80=24VAC/DC #: 1-CL, 3-YE, 4-AM, 5-RD, 6-GN, 7-BU	bestückt mit Xenon-Blitzröhre	24V AC/ DC	230V AC	115V AC
		Daten siehe BR50 FL Daten		

Crystal Clear Module

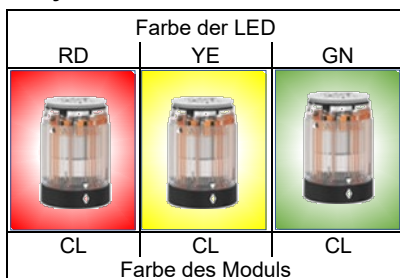

		Spannung		
Klares Modul P/N: 2825037xx1# xx: 10=230V AC, 16=115V AC, 60=24VAC/DC #: 1-CL, 3-YE, 4-AM, 5-RD, 6-GN, 7-BU	bestückt mit LED-Einsatz (Dauerlicht) LED-Farben: rot, gelb, grün	24V AC/ DC	230V AC	115V AC
		Daten siehe 7.2 Elektrische Daten		

5.2 Flexi Module

Leeres Modul, folgende Einsätze separat verfügbar:

Fully Coloured Module



		Spannung		
Farbiges Modul P/N: 282500400#0 #: 1-CL, 3-YE, 4-AM, 5-RD, 6-GN, 7-BU	LED-Einsatz: Dauerlicht	Daten siehe 7.2 Elektrische Daten		
	LED-Einsatz: Blinklicht			

5.3 Überwachtes LED-Modul - BR 50-LED-M

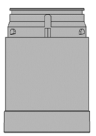

Das funktionsüberwachte LED-Modul für die Intense Signalsäule BR 50 kann einfach in Kombination mit anderen Funktionsmodulen für z.B. sicherheitsrelevante Anwendungen verwendet werden. Der Diagnosekanal des Moduls (Alarmkontakt) kann hierbei als Rückmeldung in ein übergeordnetes Steuersystem eingebunden werden.

Es können maximal 3 Module verwendet werden. *

Nennspannung	24 V DC
Funktionsbereich	21,6 V – 26,4 V DC
Nennstrom	35 mA
Alarmausgang	1 ——— 2 Max. 230 V AC/DC / 80 mA $R_{ON\ max}$ 35 Ohm geschlossen bei fehlerfreiem Betrieb

Überwachtes Modul oben:

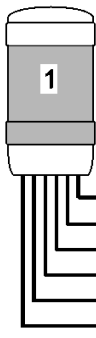

- 5+/L NC (not connected)
- 4+/L NC (not connected)
- 3+/L Alarmkontakt 2
- 2+/L Alarmkontakt 1
- 1+/L 24V DC
- /N 0V

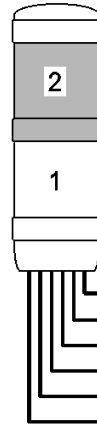

- 5+/L NC (not connected)
- 4+/L Alarmkontakt 2
- 3+/L Alarmkontakt 1
- 2+/L 24V DC 2. Stufe
- 1+/L 24V DC 1. Stufe
- /N 0V

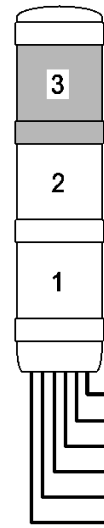

- 5+/L Alarmkontakt 2
- 4+/L Alarmkontakt 1
- 3+/L 24V DC 3. Stufe
- 2+/L 24V DC 2. Stufe
- 1+/L 24V DC 1. Stufe
- /N 0V

Überwachtes Modul unten:

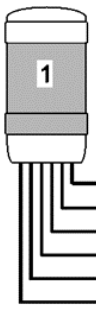

- 5+/L Alarmkontakt 2
- 4+/L Alarmkontakt 1
- 3+/L NC (not connected)
- 2+/L NC (not connected)
- 1+/L 24V DC
- /N 0V

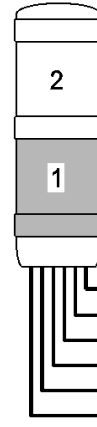

- 5+/L Alarmkontakt 2
- 4+/L Alarmkontakt 1
- 3+/L NC (not connected)
- 2+/L 24V DC 2. Stufe
- 1+/L 24V DC 1. Stufe
- /N 0V



- 5+/L Alarmkontakt 2
- 4+/L Alarmkontakt 1
- 3+/L 24V DC 3. Stufe
- 2+/L 24V DC 2. Stufe
- 1+/L 24V DC 1. Stufe
- /N 0V

*
Überwachtes Modul oben und unten: (max. 2)

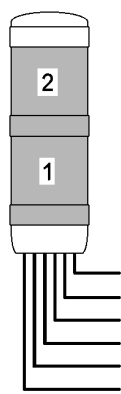

- 5+/L Alarmkontakt 2, Modul 1
- 4+/L Alarmkontakt 1, gemeinsamer Alarmkontakt 1
- 3+/L Alarmkontakt 2, Modul 2
- 2+/L 24V DC, 2. Stufe
- 1+/L 24V DC, 1. Stufe
- /N 0V

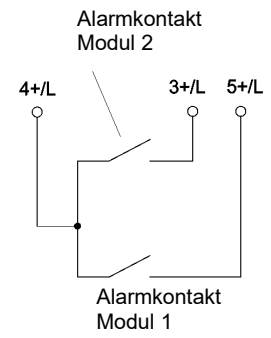



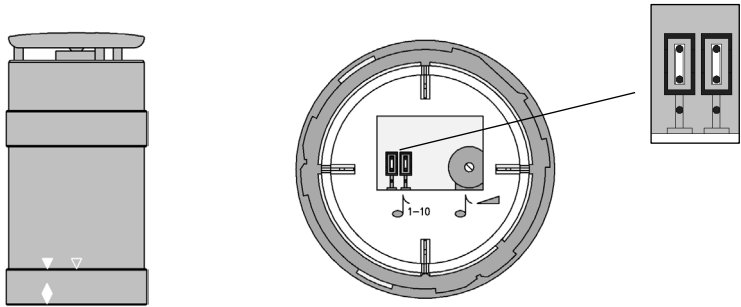

5.4 Schallgebermodul BR 50-SM

 Unvermittelte Schallauslösung kann zu Schreckreaktionen führen.

Daten siehe BR 50-SM.

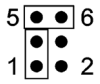

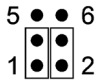
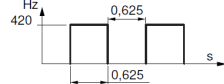
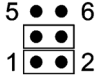
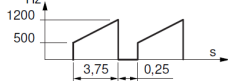
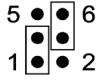
Tontabelle

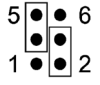
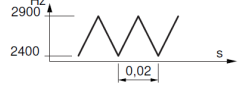
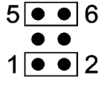
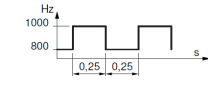
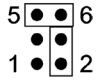
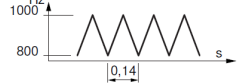
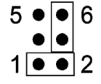
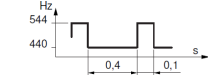
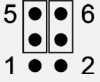
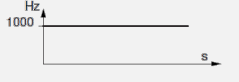
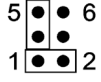
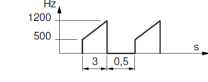
2			109		
16			110		
29			131		
35			146		
56*			167		

* Werkseinstellung

5.5 Schallgebermodul BR 50-SM HO

 Unvermittelte Schallauslösung kann zu Schreckreaktionen führen.

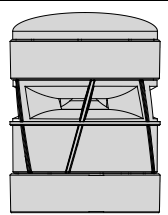

Das Schallgebermodul BR 50-SM HO kann zusätzlich zur Intense Signalsäule BR 50 als Akustikmodul eingesetzt werden. Mit dem Modul kann einer von 31 unterschiedlichen Tönen ausgewählt sowie die Lautstärke reguliert werden. Das BR50 SM-HO Modul ist immer an oberster Position zu verwenden.

Daten siehe [BR 50-SM HO](#).

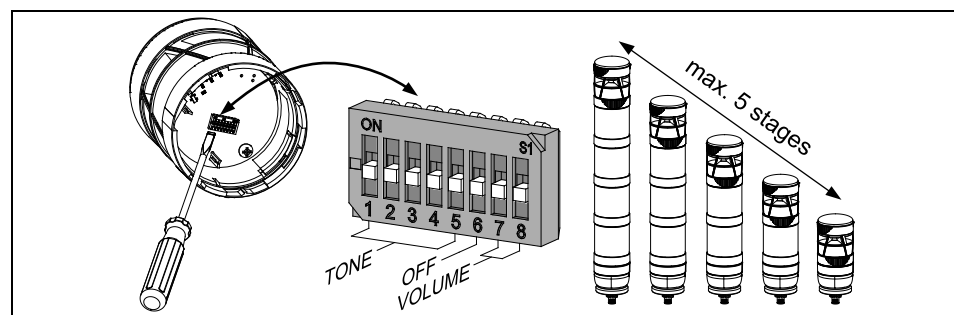

S1 (DIP1)		Volume
7	8	dB
		max. *
ON		-7
	ON	-13
ON	ON	-20

*Werkseinstellung

Selector switch S1 (DIP1) (Adjusting the base tone)						Tone-No. (♯)
1	2	3	4	5	6	
					OFF	162*
ON					OFF	2
	ON				OFF	9
ON	ON				OFF	15
		ON			OFF	18
ON		ON			OFF	22
	ON	ON			OFF	24
ON	ON	ON			OFF	26
			ON		OFF	27
ON			ON		OFF	29
	ON		ON		OFF	36
ON	ON		ON		OFF	54
		ON	ON		OFF	56
ON		ON	ON		OFF	60
	ON	ON	ON		OFF	63
ON	ON	ON	ON		OFF	71
				ON	OFF	82
ON				ON	OFF	83
	ON			ON	OFF	100
ON	ON			ON	OFF	102
		ON		ON	OFF	103
ON		ON		ON	OFF	104
	ON	ON		ON	OFF	112
ON	ON	ON		ON	OFF	123
			ON	ON	OFF	130
ON			ON	ON	OFF	131
	ON		ON	ON	OFF	146
ON	ON		ON	ON	OFF	160
		ON	ON	ON	OFF	161
ON		ON	ON	ON	OFF	163
	ON	ON	ON	ON	OFF	164
ON	ON	ON	ON	ON	OFF	1

5.6 AS-i-Modul

Das AS-i -Modul immer an unterster Position verwenden:

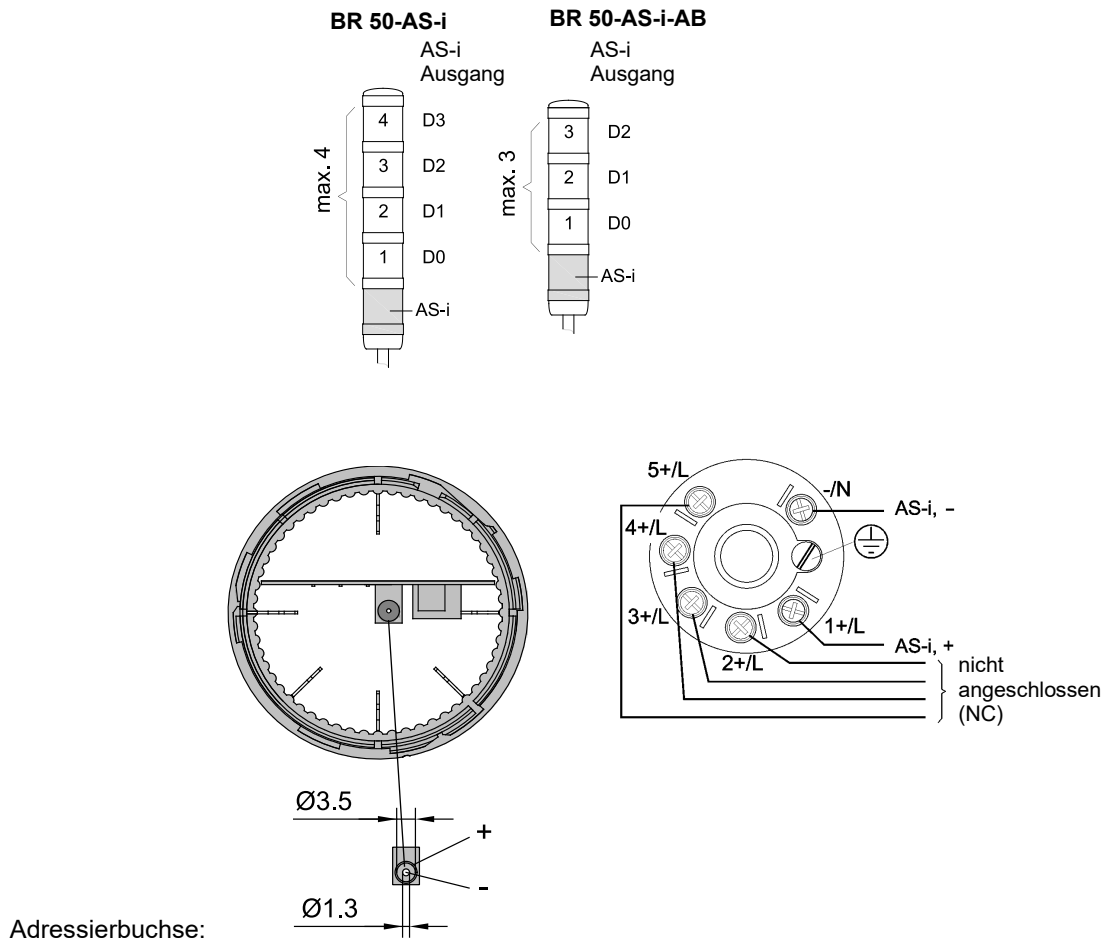

Technische Daten:

	BR 50-AS-i	BR 50-AS-i-AB
Nennspannung	26,5 V .. 31,6 V4	
max. Nennstromaufnahme	285 mA	
Maximale Anzahl der Stufen	4	3
Art der Stufen	LED-Module, Schallgebermodul BR 50-SM	
Ausgangsstrom Σ :	275 mA	
As-i -Spezifikation	AS-i 3.0 / EN 50295	
As-i-Profil	S-8.F.E	S-8.A.E
E/A -Konfiguration / configuration [HEX]	8	
ID-Code [HEX]	F.E	A.E
max. Anzahl von Slaves pro Master	31	62
Auslieferungsadresse	0	

6. Montagemöglichkeiten

Direktmontagesatz BR 50-BG

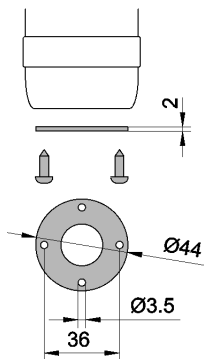

P/N: 28250210000

Rohr mit Winkel BR 50-T###

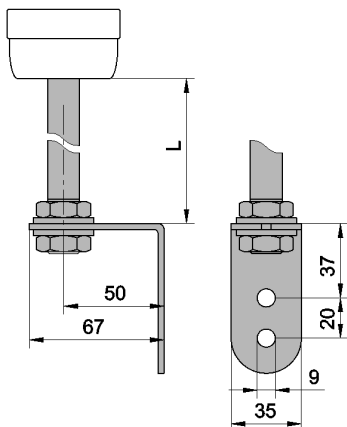

L [mm]
 BR 50-T100 62,5 P/N: 28250160010
 BR 50-T250 212,5 P/N: 28250160020
 BR 50-T400 362,5 P/N: 28250160040

Stativmontage BR 50-S###

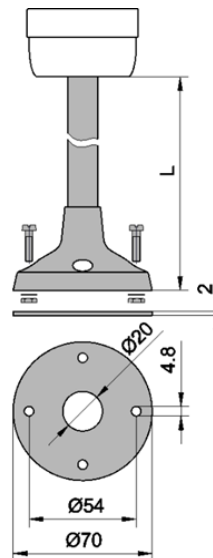

L [mm]
 BR 50-S100 97,5
 BR 50-S250 237,5
 BR 50-S400 387,5

P/N: 28250150010
 P/N: 28250150020
 P/N: 28250150040

Direktmontage mit Zugentlastung BR 50-BC-SR

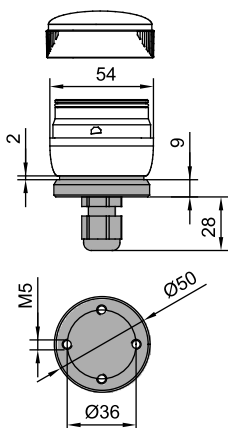

P/N: 28250280000

Flächendichtung im Lieferumfang enthalten.

Stativmontage mit Zugentlastung BR 50-BC-Sxxx-SR

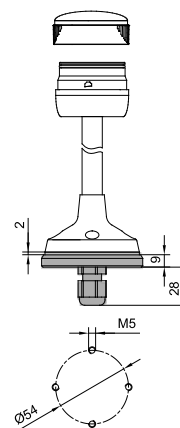

P/N: 28250290000

Winkel für Direktmontage BR 50-W (VA)

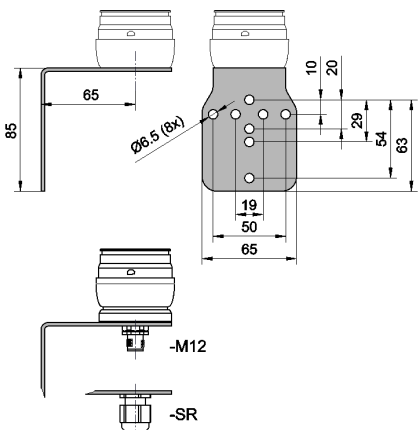

P/N: 28250180000

Maße in mm.

Bei der Montage ist geeignetes Befestigungsmaterial zu verwenden.

Winkel für Stativmontage BR 50-W (VA)

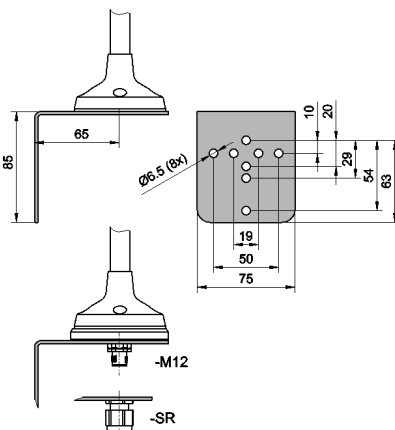

P/N: 28250190000

Winkel für Stativmontage BR 50-W (Kunststoff)

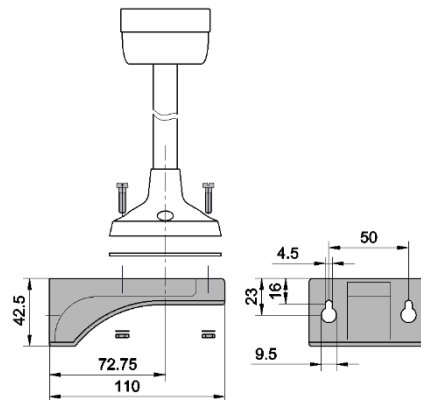

P/N: 28250200000

7. Technische Daten

7.1 Allgemein

Anzahl Module (gesamt)	max. 5	
Betriebstemperatur	-25 °C .. +50 °C	
Lagertemperatur	-40 °C .. +70 °C	
Schutzart	IP 54 (EN 60529) optional erweiterbar auf IP 65 (Ausnahme: siehe Kapitel 5.4 Schallgebermodul BR 50-SM)	
Material	Leuchtmodul: Basis- Abschlussmodul, Wandwinkel Stativ (BR 50-S) Winkel (Direkt-, Stativmontage) Rohr mit Winkel (BR 50-T###):	Polycarbonat (PC) Acrylnitril-Butadien-Styrol (ABS) Edelstahl (VA)

7.2 Elektrische Daten

	Farbe der LED	empfohlen für Modulfarbe ...	Nennspannung	Funktionsbereich	Nennstromaufnahme max.		P/N	
					AC	DC		
LED-EinsatzBA 15d <u>Dauerlicht</u>	weiß	WH, BU, AM	24V AC/DC	10 .. 30V AC/ DC	114 mA	85 mA	28213000102	
	gelb	YE			171 mA	85 mA	28213000099	
	rot	RD			121 mA	85 mA	28213000100	
	grün	GN			113 mA	85 mA	28213000101	
	weiß	WH, BU, AM	115 V AC	+/- 10%	22 mA	--	28213000118	
	gelb	YE			22 mA	--	28213000115	
	rot	RD			26 mA	--	28213000116	
	grün	GN			24 mA	--	28213000117	
	weiß	WH, BU, AM	230 V AC	220 .. 240V AC	22 mA	--	28213000106	
	gelb	YE			19 mA	--	28213000103	
	rot	RD			21 mA	--	28213000104	
	grün	GN			22 mA	--	28213000105	
	LED-Einsatz BA 15d <u>Blinklicht</u> (1 Hz)	weiß	WH, BU, AM	24V AC/DC	10 .. 30V AC/ DC	57 mA	58 mA	28213000110
		gelb	YE			86 mA	51 mA	28213000107
		rot	RD			61 mA	37 mA	28213000108
		grün	GN			57 mA	53 mA	28213000109
weiß		WH, BU, AM	115 V AC	+/- 10%	22 mA	--	28213000122	
gelb		YE			22 mA	--	28213000119	
rot		RD			26 mA	--	28213000120	
grün		GN			24 mA	--	28213000121	
weiß		WH, BU, AM	230 V AC	220 .. 240V AC	11 mA	--	28213000114	
gelb		YE			10 mA	--	28213000111	
rot		RD			11 mA	--	28213000112	
grün		GN			11 mA	--	28213000113	

	Nennspannung	Funktionsbereich	Nennstromaufnahme		Blitzenergie	Blitzenergie
			AC	DC		
Blitzlicht BR 50-FL (Xenon)	24V AC/DC	10 .. 27V AC 10 .. 35V DC	100 mA		1 J	ca. 1 Hz
	115 V AC	-10 .. +15%	20 mA	--	0,6 J	
	230 V AC	-10 .. +15%	10,5 mA	--	0,6 J	



	Nennspannung	Funktionsbereich	AC	DC	max. Schallpegel	Töne
	115 V AC	-10 .. +10%	15 mA	--		
	230 V AC	-10 .. +10%	15 mA	--		

	Nennspannung	Funktionsbereich	AC	DC	max. Schallpegel	Töne

Überwachtes Modul BR 50-M	Daten siehe 5.3 Überwachtes LED-Modul - BR 50-LED-M					
------------------------------	---	--	--	--	--	--



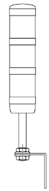
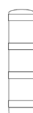

BR 50 AS-i	Daten siehe 5.6 AS-I Modul					
------------	--	--	--	--	--	--

7.3 Abmessungen

Gesamthöhe der zusammgebauten Module Gesamthöhe mit Schallgeber-Modul: + 21 mm							
Durchmesser: Ø 54mm 							
Anzahl Signalmodule	Stativmontage BR 50-S### 			Rohrmontage BR 50-Txxx 			Direktmontage 
	Rohrlänge			Rohrlänge			-
	100	250	400	100	250	400	
1	183	333	483	209	359	509	107
2	246	396	546	272	422	572	170
3	309	459	609	335	485	635	233
4	372	522	672	398	584	698	296
5	435	585	735	461	611	761	359

Maße in mm

8. Zubehör

Bezeichnung	Artikel-Nr.		
Flexi Tool	28250250000		Vereinfacht die Montage des Leuchtmittels
Moduldichtung für IP 65	28250220000		1x pro Modul plus 1x für Basismodul (BR 50-BC..)
Rohrdichtung für IP 65	28250230000		für Stativ- oder Rohrmontage
LED-Einsatz für Flexi Module <u>Dauerlicht</u>	Siehe 7.2 Elektrische Daten		Siehe 6. Montagemöglichkeiten
LED-Einsatz für Flexi Module <u>Blinklicht</u>			
BR 50-BG Direktmontagesatz	28250210000		
BR 50-T100 Rohr mit Winkel BR 50-T250 Rohr mit Winkel BR 50-T400 Rohr mit Winkel	28250160010 28250160020 28250160040		
BR 50-S100 Rohr Stativmontage	28250150010 28250150020 28250150040		
BR 50-W Winkel Direktmontage (VA)	28250180000		
BR 50-W Winkel für Stativmontage (VA)	28250190000		
BR 50-W Winkel für Stativmontage (Kunststoff)	28250200000		

9. Wartung, Service, Instandhaltung

- Bei allen Arbeiten am Gerät [Sicherheitshinweise](#) beachten.

Das Gerät erfordert keine besondere Wartung.

- Äußere Reinigung nur mit einer schwachen Seifenlösung ohne Verwendung von Lösungsmittel vornehmen.
- Zum Reinigen keine scharfkantigen Werkzeuge verwenden, insbesondere die Leuchthaube nicht zerkratzen.
- Nicht mit Hochdruck reinigen.
- Austausch von Komponenten nur mit Originalersatzteilen.
- Reparaturen grundsätzlich nur im Herstellerwerk ausführen lassen.

Umbauten, Änderungen, fehlerhafter und unzulässiger Einsatz sowie die Nichtbeachtung der Hinweise dieser Betriebsanleitung schließen eine Gewährleistung aus.

10. Außerbetriebnahme, Demontage und Entsorgung

- Bei allen Arbeiten am Gerät [Sicherheitshinweise](#) beachten.

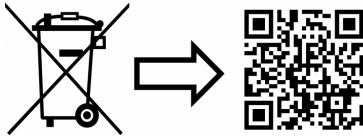

www.pfannenberg.com/disposal



Pfannenberg 
ELECTRO-TECHNOLOGY FOR INDUSTRY

Pfannenberg GmbH

Werner-Witt-Straße 1 • D- 21035 Hamburg

Tel.: +49/ (0)40/ 734 12-0

Fax: +49/ (0)40/ 734 12-101

service@pfannenberg.com

<http://www.pfannenberg.com>

Table of contents

1. Intended use2
2. Safety information2
3. Electrical connection base module3
3.1 BR 50-BC with connecting cable3
3.2 Connection with M12 plug3
4. Assembly4
4.1 Inserting/replacing the lamp4
4.2 Assembling the modules4
5. Function modules:5
5.1 Easy Module5
5.2 Flexi Module5
5.3 Monitored LED module - BR 50-LED-M6
5.4 Sounder module BR 50-SM7
5.5 Sounder module BR 50-SM HO8
5.6 AS-i module9
6. Assembly possibilities10
7. Technical data11
7.1 General11
7.2 Electrical data11
7.3 Dimensions12
8. Accessories13
9. Maintenance, service, repairs14
10. Decommissioning, dismantling and disposal14

Observe proprietary notice in accordance with DIN ISO 16016!

English translation

1. Intended use





Signal towers of the Intense BR 50 series serve for signaling hazards/statuses, for example, in industry, trade and building areas.

The various function modules offer different signaling possibilities such as continuous light, blinking light or XENON flashing light.

Use of the BR 50-SM HO sound generator element also offers an additional acoustic alarm.

The devices are designed for indoor and outdoor use and are only intended for fixed assembly.

2. Safety information

	<p>DANGER - Danger to life due to electric shock Voltage-carrying units and exposed connection cables may cause electric shocks and serious accidents.</p> <ul style="list-style-type: none"> - Work on electrical connections may only be carried out by trained and authorized electrical specialists. - De-energize all supply cables and secure against switching back on prior to assembly. Always ensure absence of voltage. - BR 50-FL: Wait for the discharge phase of 2 minutes for the electrical components. The unit should only be opened afterwards. - The operating voltage must only be applied when the housing is firmly closed.
	<p>WARNING - Danger due to unauthorized use of the devices</p> <ul style="list-style-type: none"> - Improper use may lead to serious accidents. - The devices must only be operated when undamaged and within the specified parameters. - The function of the device can only be guaranteed if the function modules are correctly joined together. - The devices are only intended for fixed assembly.
	<p>DANGER - Danger due to damage to the devices</p> <ul style="list-style-type: none"> - Always observe the information on the type plate when installing and maintaining the units.
	<p>CAUTION - Risk of injury due to sharp edges or heated components</p> <ul style="list-style-type: none"> - Wear suitable personal protective equipment (PPE) for installation, assembly or service/maintenance work. - Lay wires well away from sharp edges, corners and internal components; avoid collisions with parts.
	<p>CAUTION - Impairment of vision</p> <ul style="list-style-type: none"> - Avoid constant, direct glances into the activated lights to prevent impairment of vision. - BR 50-FL: Unexpected triggering of the flash can lead to startled reactions.

3. Electrical connection base module

3.1 BR 50-BC with connecting cable

12 – 230 V
Cable connection:
Torque 0.6 Nm

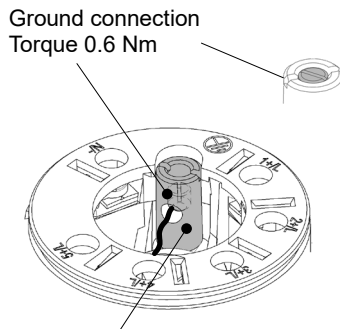
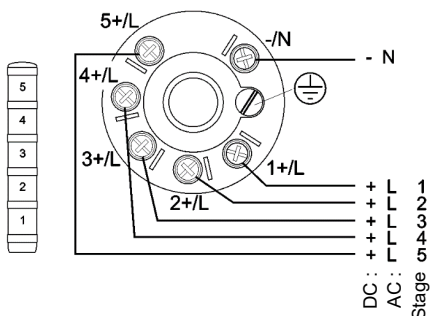

For tube or stand assembly (option):
Loosen the external screw, fit the tube and
tighten the screw again.
Torque: 1.5 Nm

Ø supply cable max. 1.5 mm²
cable end sleeve 8mm

115/ 230V AC for stand or tube assembly:
Make the electrical connection with a sheathed cable.

BR 50-BC

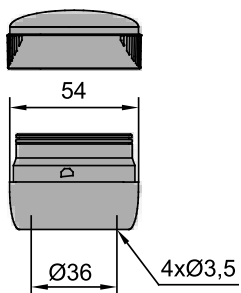

P/N: 28250010000

3.2 Connection with M12 plug

12 – 24 V AC/DC

BR 50-BC-M12

BR 50-BC-Sxxx-M12

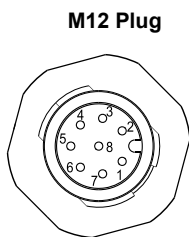

Connection	BR50- stage...
1	1 / +
2	2 / +
3	3 / +
4	4 / +
5	5 / +
6	/
7	- (COM)
8	/

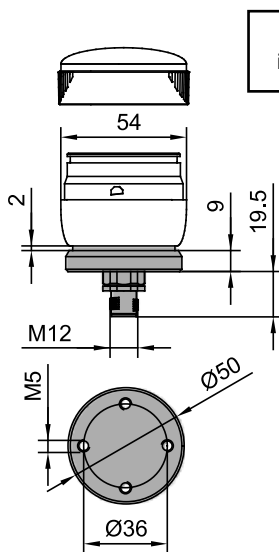

Surface seal
included in delivery.

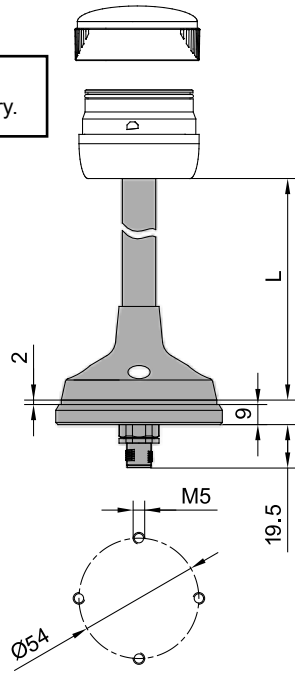

P/N: 28250126000

P/N: 28250126010 97,5
P/N: 28250126020 237,5
P/N: 28250126040 387,5
L [mm]

4. Assembly

4.1 Inserting/replacing the lamp

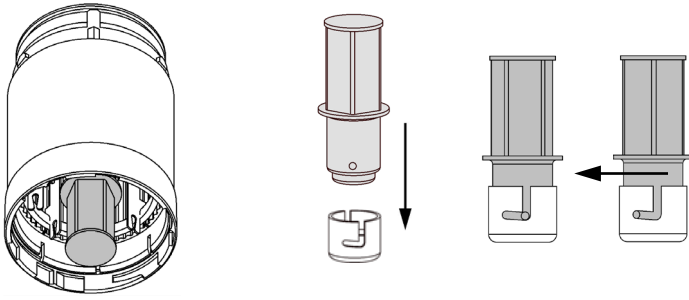

The flexi-tool can be used as an accessory for easier handling when replacing a lamp, see [Flexi Tool](#). Flexi-tool

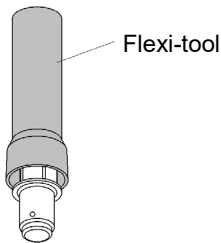

4.2 Assembling the modules

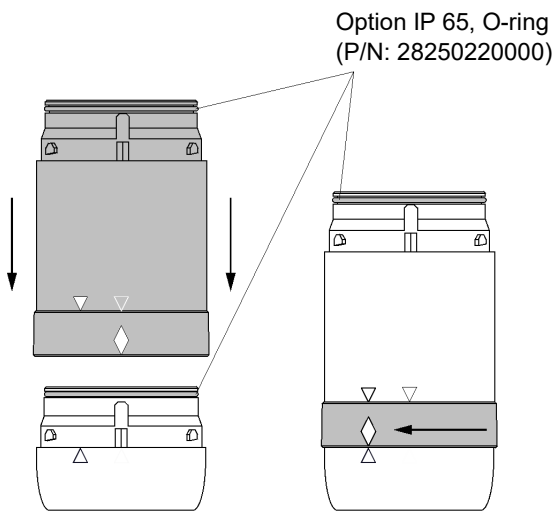

Installation O-ring IP 65 (P/N: 28250230000)
for stand or tube assembly

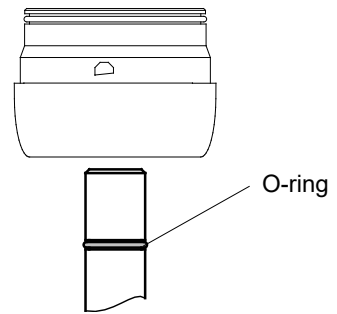

5. Function modules:

5.1 Easy Module

The module is equipped with a pre-assembled light source.

Fully Colored Module



		Voltage		
Colored module P/N: 2825037*	Equipped with LED insert (continuous light) LED colors: white, red, yellow, green	24 V AC/DC	230 V AC	115 V AC
		For data, see chapter 7.2 Electrical data		
Colored module P/N: 2825007xx#0 xx: 10=230 V AC, 16=115 V AC, 80=24 V AC/DC #: 1-CL, 3-YE, 4-AM, 5-RD, 6-GN, 7-BU	Equipped with Xenon flash tube	24 V AC/DC	230 V AC	115 V AC
		For data, see BR50 FL Data		

Crystal Clear Module

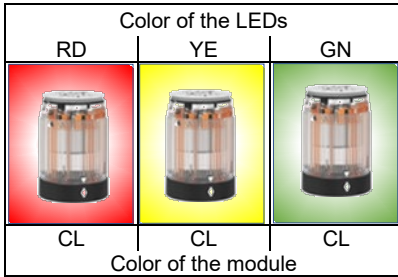

		Voltage		
Clear module P/N: 2825037xx1# xx: 10=230 V AC, 16=115 V AC, 60=24 V AC/DC #: 1-CL, 3-YE, 4-AM, 5-RD, 6-GN, 7-BU	Equipped with LED insert (continuous light) LED colors: red, yellow, green	24 V AC/DC	230 V AC	115 V AC
		For data, see 7.2 Electrical data		

5.2 Flexi Module

Empty module, following inserts available separately:

Fully Colored Module

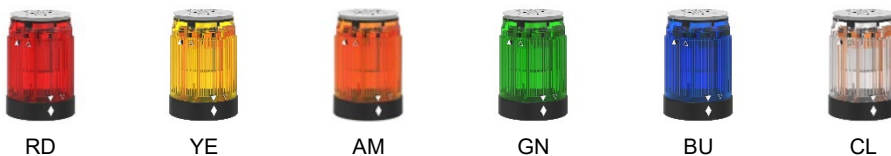

		Voltage		
Colored module P/N: 282500400#0 #: 1-CL, 3-YE, 4-AM, 5-RD, 6-GN, 7-BU	LED insert: Continuous light	For data, see 7.2 Electrical data		
	LED insert: Blinking light			

5.3 Monitored LED module - BR 50-LED-M

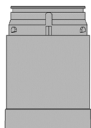

The function-monitored LED module for the Intense BR 50 signal tower can be used easily in combination with other function modules for safety-relevant applications, for example. The diagnosis channel of the module (alarm contact) can be incorporated here into a higher-level control system as a feedback signal.

A maximum of 3 modules can be used. *

Nominal voltage	24 V DC
Functional area	21.6 V – 26.4 V DC
Nominal current	35 mA
Alarm output	1 ——— 2 Max. 230 V AC/DC / 80 mA R _{ON max} 35 Ohm closed in error-free operation

Monitored module top:

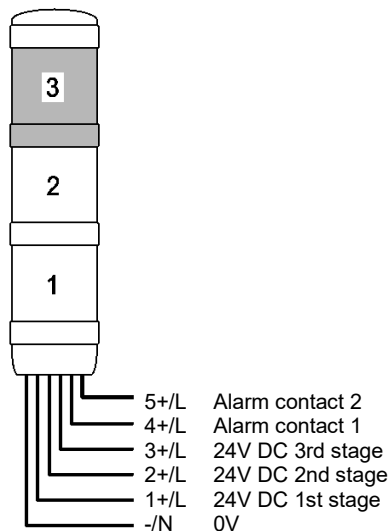
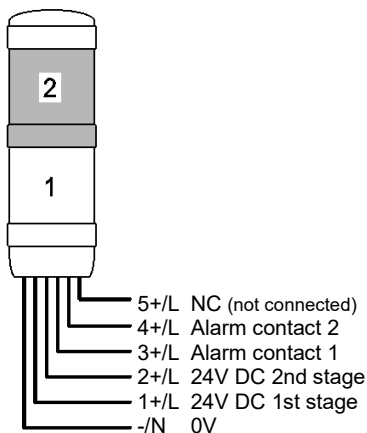
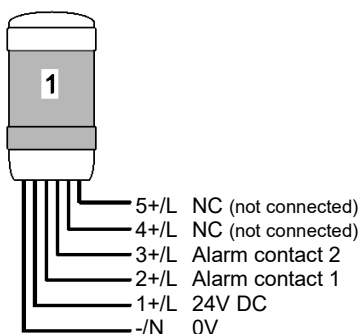

Monitored module bottom:

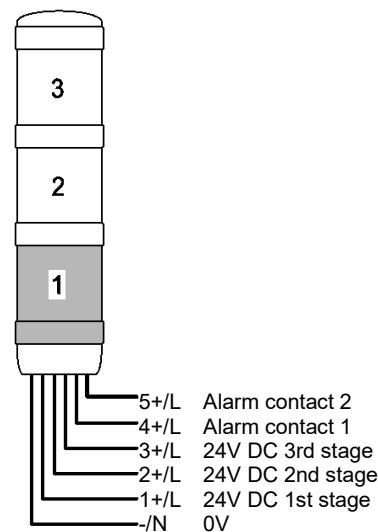
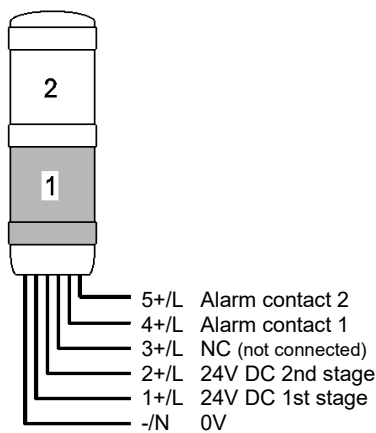
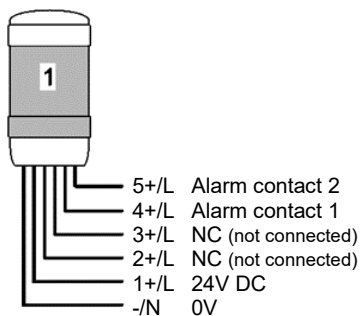

*
Monitored module top and bottom: (max. 2)

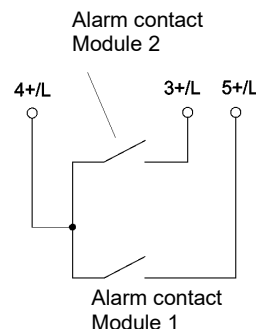
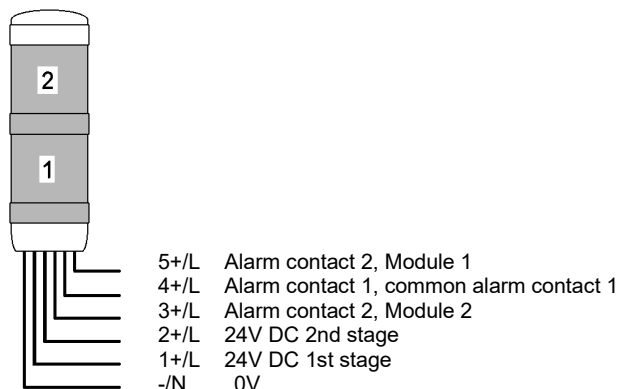







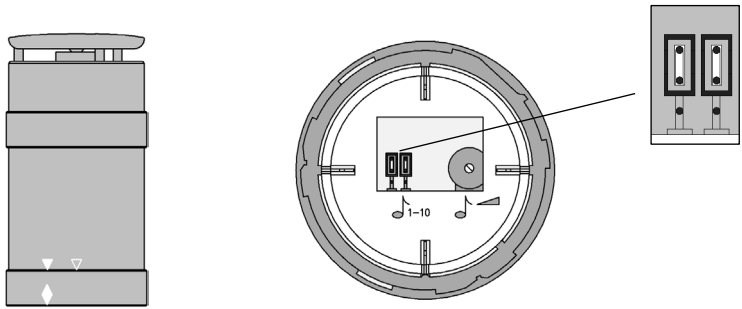

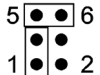

5.4 Sounder module BR 50-SM

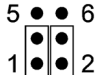
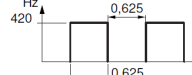
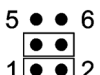
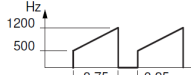
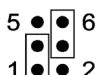
 Unexpected triggering of the sound can lead to startled reactions.

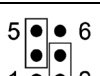
For data, see [BR 50-SM](#).

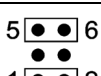
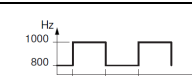
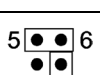

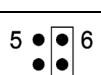
Tone table

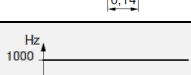
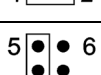
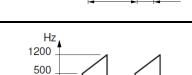
2			109		
16			110		
29			131		
35			146		
56*			167		

* Factory setting

5.5 Sounder module BR 50-SM HO

 Sudden sound activation can lead to startle reactions.

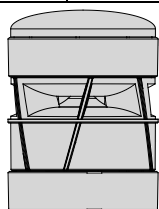

The BR 50-SM HO sound module can be used as an acoustic module in addition to the Intense signal tower BR 50. The module allows for the selection of one of 31 different tones, and the volume can be adjusted. The BR 50-SM HO module must always be installed at the top position.

For data, see [BR 50-SM HO](#).

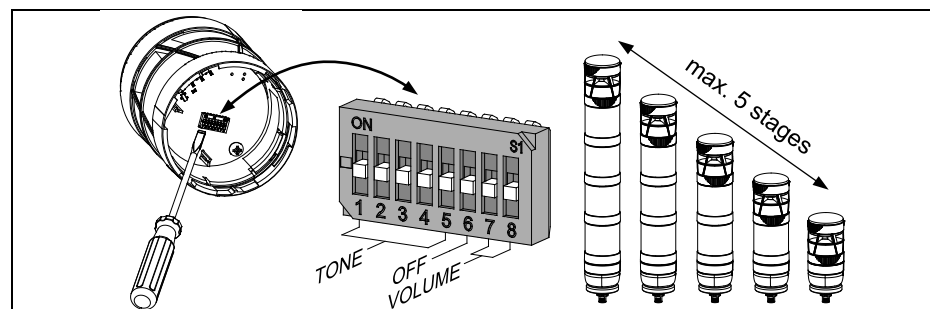

S1 (DIP1)		Volume
7	8	dB
		max. *
ON		-7
	ON	-13
ON	ON	-20

*factory setting

Selector switch S1 (DIP1) (Adjusting the base tone)						Tone-No. (♯)
1	2	3	4	5	6	
					OFF	162*
ON					OFF	2
	ON				OFF	9
ON	ON				OFF	15
		ON			OFF	18
ON		ON			OFF	22
	ON	ON			OFF	24
ON	ON	ON			OFF	26
			ON		OFF	27
ON			ON		OFF	29
	ON		ON		OFF	36
ON	ON		ON		OFF	54
		ON	ON		OFF	56
ON		ON	ON		OFF	60
	ON	ON	ON		OFF	63
ON	ON	ON	ON		OFF	71
				ON	OFF	82
ON				ON	OFF	83
	ON			ON	OFF	100
ON	ON			ON	OFF	102
		ON		ON	OFF	103
ON		ON		ON	OFF	104
	ON	ON		ON	OFF	112
ON	ON	ON		ON	OFF	123
			ON	ON	OFF	130
ON			ON	ON	OFF	131
	ON		ON	ON	OFF	146
ON	ON		ON	ON	OFF	160
		ON	ON	ON	OFF	161
ON		ON	ON	ON	OFF	163
	ON	ON	ON	ON	OFF	164
ON	ON	ON	ON	ON	OFF	1

5.6 AS-i module

Always use the AS-i module at the lowest position:

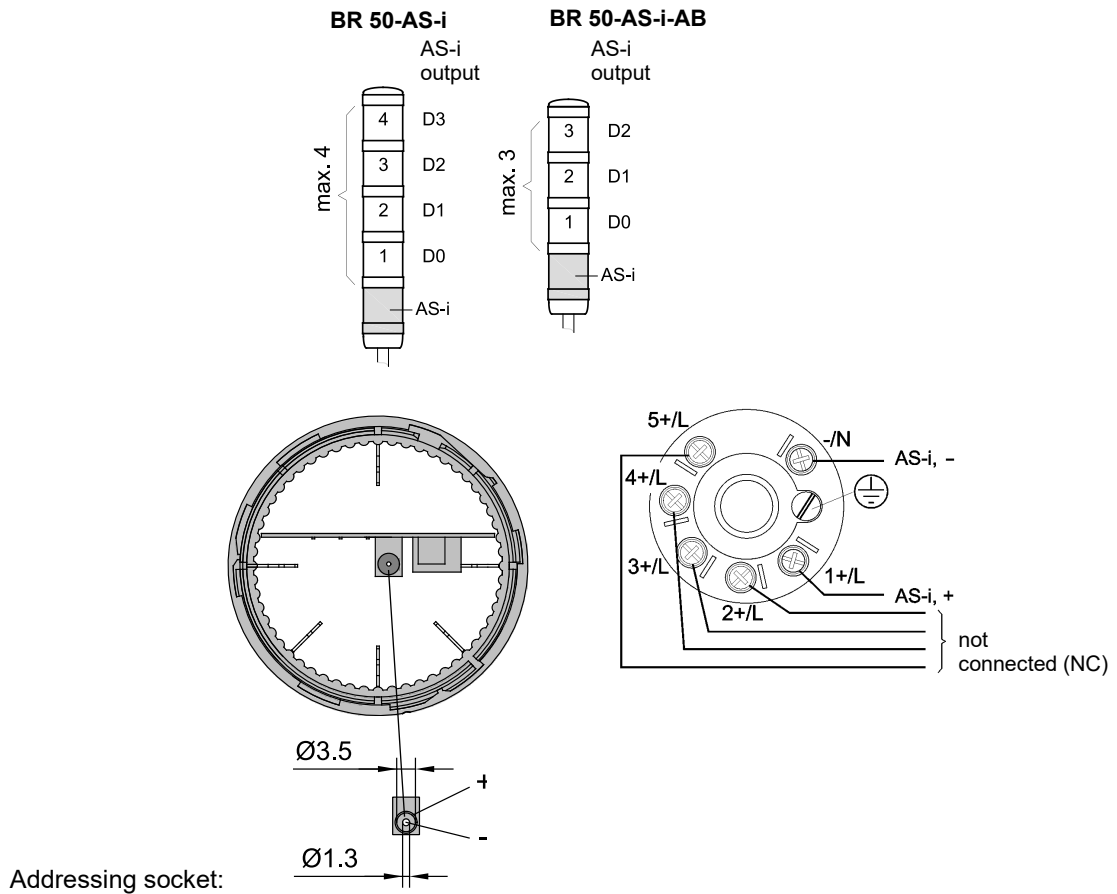

Technical data:

	BR 50-AS-i	BR 50-AS-i-AB
Nominal voltage	26.5 V .. 31.6 V	
Max. nominal current consumption	285 mA	
Maximum number of stages	4	3
Type of stages	LED modules, sound generator module BR 50-SM	
Output current total Σ :	275 mA	
As-i specification	AS-i 3.0 / EN 50295	
As-i profile	S-8.F.E	S-8.A.E
I/O configuration / configuration [HEX]	8	
ID code [HEX]	F.E	A.E
Max. number of slaves per master	31	62
Delivery address	0	

6. Assembly possibilities

Direct assembly kit BR 50-BG

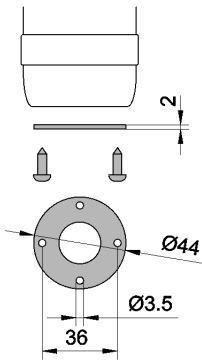

P/N: 28250210000

Tube with bracket BR 50-T###

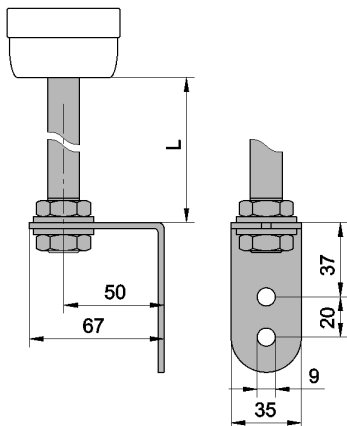

L [mm]		
BR 50-T100	62.5	P/N: 28250160010
BR 50-T250	212.5	P/N: 28250160020
BR 50-T400	362.5	P/N: 28250160040

Stand assembly BR 50-S###

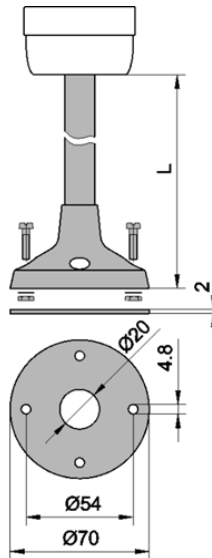

	L [mm]
BR 50-S100	97.5
BR 50-S250	237.5
BR 50-S400	387.5

P/N: 28250150010
P/N: 28250150020
P/N: 28250150040

Direct mounting with strain relief
BR 50-BC-SR

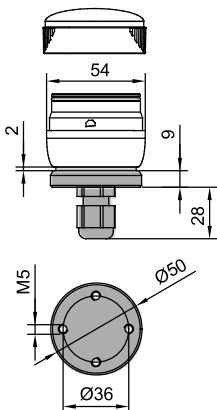

P/N: 28250280000

Surface seal included in delivery.

Stand mounting with strain relief
BR 50-BC-Sxxx-SR

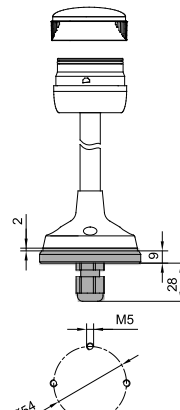

P/N: 28250290000

Bracket for direct assembly BR 50-W (VA)

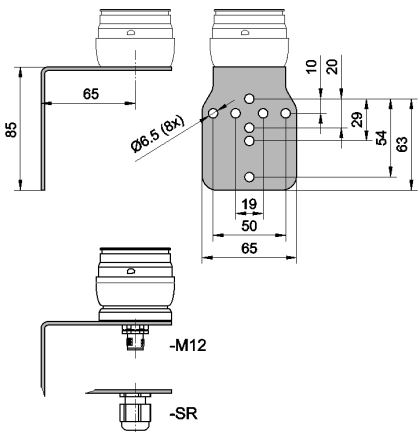

P/N: 28250180000
Dimensions in mm.
Suitable fastening material must be used for assembly.

Bracket for stand assembly BR 50-W (VA)

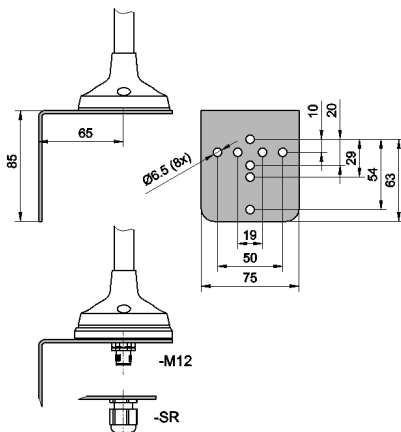

P/N: 28250190000

Bracket for stand assembly BR 50-W (plastic)

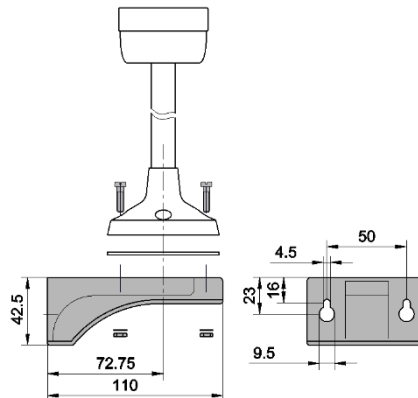

P/N: 28250200000

7. Technical data

7.1 General

Number of modules (total)	max. 5	
Operating temperature	-25 °C .. +50 °C	
Storage temperature	-40 °C .. +70 °C	
Ingress protection	IP 54 (EN 60529) optionally extendable to IP 65 (exception: see chapter 5.4 Sounder module BR 50-SM)	
Material	Lamp module:	Polycarbonate (PC)
	Base-/ Cover module, wall bracket stand (BR 50-S)	Acrylonitrile butadiene styrene (ABS)
	Bracket (direct, stand assembly) Tube with bracket (BR 50-T###):	Stainless steel (VA)

7.2 Electrical data

	Color of the LEDs	Recommended for module color ...	Rated voltage	Voltage range	Max. current consumption		P/N
					AC	DC	
LED insertBA 15d Continuous light	white	WH, BU, AM	24 V AC/DC	10 .. 30 V AC/DC	114 mA	85 mA	28213000102
	yellow	YE			171 mA	85 mA	28213000099
	red	RD			121 mA	85 mA	28213000100
	green	GN			113 mA	85 mA	28213000101
	white	WH, BU, AM	115 V AC	+/- 10%	22 mA	--	28213000118
	yellow	YE			22 mA	--	28213000115
	red	RD			26 mA	--	28213000116
	green	GN			24 mA	--	28213000117
	white	WH, BU, AM	230 V AC	220 .. 240V AC	22 mA	--	28213000106
	yellow	YE			19 mA	--	28213000103
	red	RD			21 mA	--	28213000104
	green	GN			22 mA	--	28213000105
LED insert BA 15d Blinking light (1 Hz)	white	WH, BU, AM	24 V AC/DC	10 .. 30 V AC/DC	57 mA	58 mA	28213000110
	yellow	YE			86 mA	51 mA	28213000107
	red	RD			61 mA	37 mA	28213000108
	green	GN			57 mA	53 mA	28213000109
	white	WH, BU, AM	115 V AC	+/- 10%	22 mA	--	28213000122
	yellow	YE			22 mA	--	28213000119
	red	RD			26 mA	--	28213000120
	green	GN			24 mA	--	28213000121
	white	WH, BU, AM	230 V AC	220 .. 240V AC	11 mA	--	28213000114
	yellow	YE			10 mA	--	28213000111
	red	RD			11 mA	--	28213000112
	green	GN			11 mA	--	28213000113

	Rated voltage	Voltage range	Current consumption		Flash energy	Flash energy
			AC	DC		
Flashing light BR 50-FL (Xenon)	24 V AC/DC	10 .. 27 V AC 10 .. 35 V DC	100 mA		1 J	approx. 1 Hz
	115 V AC	-10 .. +15 %	20 mA	--	0.6 J	
	230 V AC	-10 .. +15 %	10.5 mA	--	0.6 J	





	Rated voltage	Voltage range	AC	DC	Max. sound level	Tones
	115 V AC	-10 .. +10%	15 mA	--		
	230 V AC	-10 .. +10%	15 mA	--		

	Rated voltage	Voltage range	AC	DC	Max. sound level	Tones

Monitored module BR 50-M	For data, see 5.3 Monitored LED module - BR 50-LED-M					
-----------------------------	--	--	--	--	--	--





BR 50 AS-i	For data, see 5.6 AS-i module					
------------	---	--	--	--	--	--

7.3 Dimensions

Total height of the assembled modules Total height with sound generator module: + 21 mm							
Diameter: Ø 54 mm 							
	Stand assembly BR 50-S### 			Tube assembly BR 50-Txxx 			Direct assembly 
Number of signal modules	Tube length			Tube length			-
	100	250	400	100	250	400	
1	183	333	483	209	359	509	107
2	246	396	546	272	422	572	170
3	309	459	609	335	485	635	233
4	372	522	672	398	584	698	296
5	435	585	735	461	611	761	359

Dimensions in mm

8. Accessories

Designation	Item No.	
Flexi-tool	28250250000	 <p>simplifies assembly of the lamp</p>
Module seal for IP 65	28250220000	 <p>1x per module plus 1x for base module (BR 50-BC..)</p>
Tube seal for IP 65	28250230000	 <p>for stand or tube assembly</p>
LED insert for Flexi Module <u>Continuous light</u>	See 7.2 Electrical data	
LED insert for Flexi Module <u>Blinking light</u>		
BR 50-BG direct assembly kit	28250210000	See chapter 6. Assembly possibilities
BR 50-T100 tube with bracket	28250160010	
BR 50-T250 tube with bracket	28250160020	
BR 50-T400 tube with bracket	28250160040	
BR 50-S100 tube stand assembly	28250150010 28250150020 28250150040	
BR 50-W bracket direct assembly (VA)	28250180000	
BR 50-W bracket for stand assembly (VA)	28250190000	
BR 50-W bracket for stand assembly (plastic)	28250200000	

9. Maintenance, service, repairs

- Observe the [Safety information](#) during all work on the device.

The device requires no special maintenance.

- Clean the outside only with a weak soap solution without using solvents.
- Do not use sharp tools for cleaning and especially avoid scratching the lens.
- Do not clean with high pressure.
- Only replace components using original spare parts.
- Only have repairs carried out at the manufacturer's premises.

Conversions, modifications, improper and impermissible use as well as failure to observe the notes in this operating instructions shall void any warranty.

10. Decommissioning, dismantling and disposal

- Observe the [Safety information](#) during all work on the device.

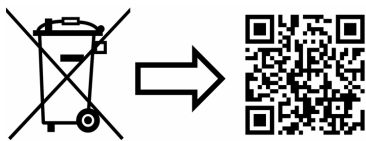

www.pfannenberg.com/disposal



Pfannenberg GmbH

Werner-Witt-Strasse 1 · D- 21035 Hamburg

Tel.: +49/ (0)40/ 734 12-0

Fax: +49/ (0)40/ 734 12-101

service@pfannenberg.com

<http://www.pfannenberg.com>

Sommaire

1. Utilisation conforme.....	2
2. Consignes de sécurité.....	2
3. Branchement électrique du module de terminaison de base.....	3
3.1 BR 50-BC avec câble de raccordement	3
3.2 Branchement avec connecteur M12	3
4. Assemblage	4
4.1 Insertion / remplacement de la source lumineuse	4
4.2 Assemblage des modules	4
5. Modules fonctionnels:	5
5.1 Modules Easy	5
5.2 Modules Flexi	5
5.3 Module à DEL surveillé – BR 50-DEL-M.....	6
5.4 Module de sirène BR 50-SM.....	7
5.5 Module de sirène BR 50-SM HO	8
5.6 Module AS-i.....	9
6. Possibilités de montage	10
7. Données techniques	11
7.1 Généralités	11
7.2 Données électriques.....	11
7.3 Dimensions.....	12
8. Accessoires.....	13
9. Maintenance, entretien, réparation.....	14
10. Mise hors service, démontage et élimination	14

1. Utilisation conforme





Les colonnes lumineuses de la série Intense BR 50 ont été conçues en vue de la signalisation, par ex. d'indicateurs de danger ou d'état dans l'industrie, le commerce et les bâtiments.

Les différents modules fonctionnels offrent différentes possibilités de signalisation, comme le feu fixe, le feu clignotant ou le flash au XÉNON.

De plus, l'utilisation de l'élément de sirène BR 50-SM HO offre une alarme sonore supplémentaire.

Les appareils conviennent à une utilisation intérieure comme extérieure et sont strictement réservés à une installation stationnaire.

2. Consignes de sécurité

	<p>DANGER – Danger de mort par électrocution</p> <p>Les appareils sous tension et les câbles de raccordement dénudés peuvent provoquer des décharges électriques et des accidents graves.</p> <ul style="list-style-type: none"> - Les travaux sur les branchements électriques sont strictement réservés aux techniciens dûment autorisés et formés en électrotechnique. - Avant l'installation, mettre tous les câbles d'alimentation électrique hors tension et les sécuriser contre tout rétablissement de la tension. Contrôler systématiquement l'absence de tension. - BR 50-FL : attendre la fin de la phase de décharge de 2 minutes pour les composants électriques. Ne pas ouvrir l'appareil auparavant. - La tension de service doit uniquement être appliquée lorsque le boîtier est solidement fermé.
	<p>AVERTISSEMENT – Danger en cas d'utilisation non conforme des appareils</p> <ul style="list-style-type: none"> - Une utilisation non conforme peut entraîner des accidents graves. - Utiliser uniquement les appareils à condition que ceux-ci soient intacts et conformes aux caractéristiques spécifiées. - Le fonctionnement de l'appareil est uniquement garanti à condition que les modules fonctionnels soient correctement assemblés. - Les appareils sont uniquement destinés à une installation stationnaire.
	<p>DANGER - Risques liés à la détérioration des appareils</p> <ul style="list-style-type: none"> - Lors de l'installation et de la maintenance des appareils, prenez toujours en compte les indications figurant sur la plaque signalétique.
	<p>ATTENTION - Risques de blessures par des arêtes vives ou des composants chauds</p> <ul style="list-style-type: none"> - Pendant les travaux d'installation, de montage ou d'entretien / maintenance, porter l'équipement de protection individuelle (EPI) approprié. - Poser les câbles à l'écart des arêtes vives, des coins et des composants internes, éviter toute collision avec les composants.
	<p>ATTENTION - Déficience de la vue</p> <ul style="list-style-type: none"> - Pour éviter toute altération de la vision, évitez de regarder fixement et directement le feu flash activé. - BR 50-FL : le déclenchement soudain du flash peut effrayer le personnel.

3. Branchement électrique du module de terminaison de base

3.1 BR 50-BC avec câble de raccordement

12 – 230 V

Raccord de câbles :

Couple de rotation 0,6 Nm

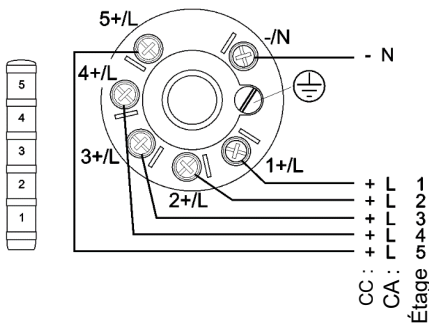

Ø câble d'alimentation max. 1,5 mm²
embout de fil 8mm

Prise de terre
Couple de rotation :
0,6 Nm

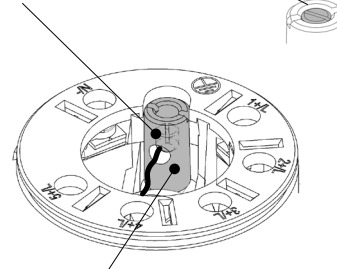

En cas de montage sur tube ou sur trépied (option) :
Desserrer la vis extérieure, monter le tube puis resserrer la vis
Couple de serrage : 1,5 Nm



115/230 V CA en cas de montage sur trépied ou sur tube :
Réaliser le branchement électrique à l'aide d'un câble gainé.

BR 50-BC

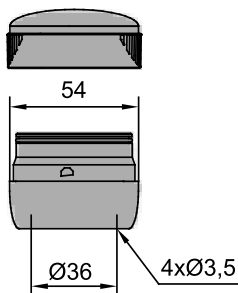

Réf. : 28250010000

3.2 Branchement avec connecteur M12

12 – 24 V CA/CC

BR 50-BC-M12

BR 50-BC-Sxxx-M12

Connecteur M12

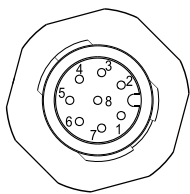

Branchement
BR 50- étage...

1	1 / +
2	2 / +
3	3 / +
4	4 / +
5	5 / +
6	/
7	- (COM)
8	/

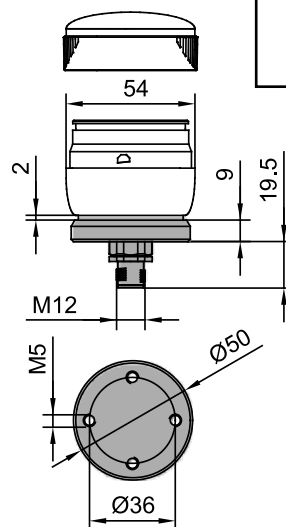

Réf. : 28250126000

Joint de surface
inclus dans la
livraison.

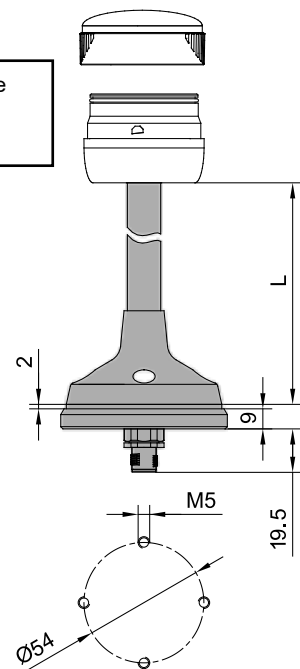

Réf. : 28250126010 97,5
Réf. : 28250126020 237,5
Réf. : 28250126040 387,5
L [mm]

4. Assemblage

4.1 Insertion / remplacement de la source lumineuse

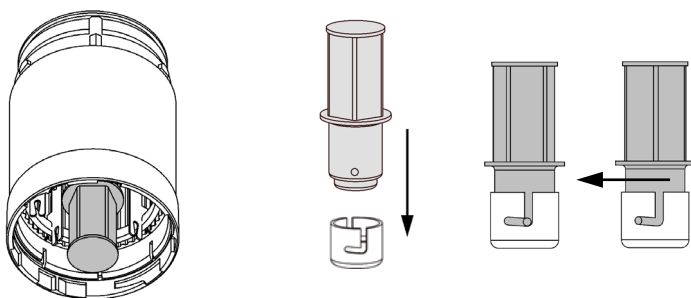

Pour faciliter la manipulation lors du remplacement d'une source lumineuse, il est possible d'employer l'outil d'extraction de bulbe comme accessoire, voir [Outil d'extraction de bulbe](#).

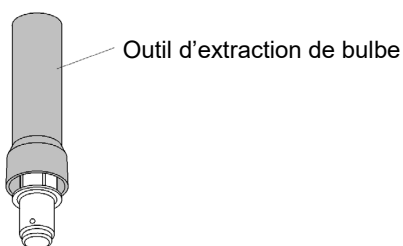

4.2 Assemblage des modules

28250230000)

Option IP 65, joint torique

(Réf. : 28250220000)

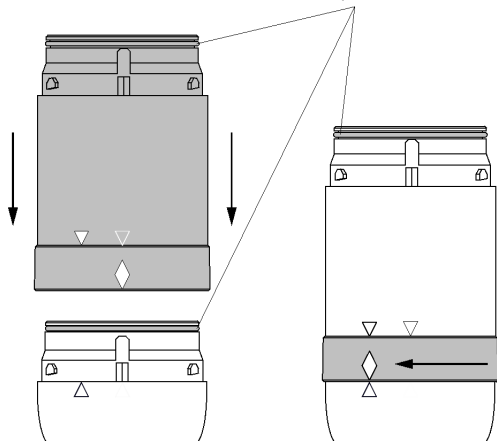

Montage joint torique IP 65 (réf. :

en cas de montage sur trépied ou sur tube

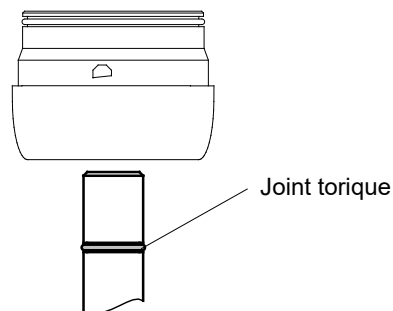

5. Modules fonctionnels:

5.1 Modules Easy

Le module est équipé d'une source lumineuse déjà montée.

Fully Coloured Module



RD



YE



AM



GN



BU



CL

		Tension		
Module de couleur Réf. : 2825037*	équipé d'un insert à DEL (feu fixe) Couleurs des DEL : blanc, rouge, jaune, vert	24 V CA/CC	230 V CA	115 V CA
		Caractéristiques, voir 7.2 Données électriques		
Module de couleur Réf. : 2825007xx#0 xx : 10=230 V CA, 16=115 V CA, 80=24 V CA/CC # : 1-CL, 3-YE, 4-AM, 5-RD, 6-GN, 7-BU	équipé de flashes au xénon	24 V CA/CC	230 V CA	115 V CA
		Caractéristiques, voir BR50 FL		

Modules Crystal Clear

Couleur de la DEL		
RD	YE	GN
CL	CL	CL
Couleur du module		

		Tension		
Module clair Réf. : 2825037xx1# xx : 10=230 V CA, 16=115 V CA, 60=24 V CA/CC # : 1-CL, 3-YE, 4-AM, 5-RD, 6-GN, 7-BU	équipé d'un insert à DEL (feu fixe) Couleurs des DEL : rouge, jaune, vert	24 V CA/CC	230 V CA	115 V CA
		Caractéristiques, voir 7.2 Données électriques		

5.2 Modules Flexi

Module vide, inserts suivants disponibles séparément :

Fully Coloured Module



RD



YE



AM



GN



BU



CL

		Tension		
Module de couleur Réf. : 282500400#0 # : 1-CL, 3-YE, 4-AM, 5-RD, 6-GN, 7-BU	Insert à DEL : feu fixe	Caractéristiques, voir 7.2 Données électriques		
	Insert à DEL : feu clignotant			

5.3 Module à DEL surveillé – BR 50-DEL-M

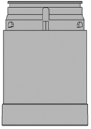

Le module à DEL à fonction surveillée pour la colonne lumineuse Intense BR 50 peut être facilement employé en combinaison avec d'autres modules fonctionnels, par ex. pour les applications dédiées à la sécurité. Le canal de diagnostic du module (contact d'alarme) peut alors être intégré à un système de commande supérieur en tant qu'information en retour.

Il est possible d'employer au maximum 3 modules. *

Tension nominale	24 V CC
Plage de fonctionnement	21,6 V – 26,4 V CC
Courant nominal	35 mA
Sortie de l'alarme 1 ——— 2	Max. 230 V CA/CC / 80 mA $R_{ON\ max}$ 35 Ω fermé en cas de fonctionnement sans défaut

Module surveillé en haut :

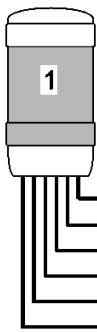

5+/L NC (non connecté)
4+/L NC (non connecté)
3+/L Contact d'alarme 2
2+/L Contact d'alarme 1
1+/L 24 V CC
-/N 0 V

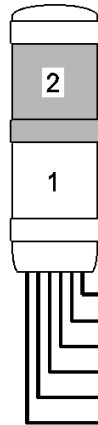

5+/L NC (non connecté)
4+/L Contact d'alarme 2
3+/L Contact d'alarme 1
2+/L 24 V CC 2^e étage
1+/L 24 V CC 1^{er} étage
-/N 0 V

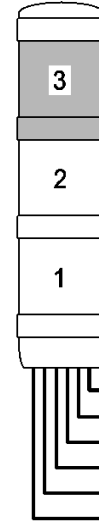

5+/L Contact d'alarme 2
4+/L Contact d'alarme 1
3+/L 24 V CC 3^e étage
2+/L 24 V CC 2^e étage
1+/L 24 V CC 1^{er} étage
-/N 0 V

Module surveillé en bas :

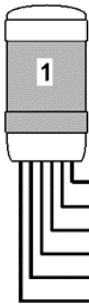

5+/L Contact d'alarme 2
4+/L Contact d'alarme 1
3+/L NC (non connecté)
2+/L NC (non connecté)
1+/L 24 V CC
-/N 0 V

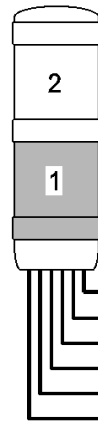

5+/L Contact d'alarme 2
4+/L Contact d'alarme 1
3+/L NC (non connecté)
2+/L 24 V CC 2^e étage
1+/L 24 V CC 1^{er} étage
-/N 0 V

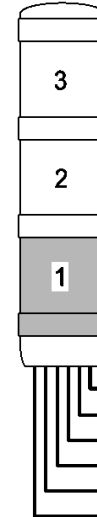

5+/L Contact d'alarme 2
4+/L Contact d'alarme 1
3+/L 24 V CC 3^e étage
2+/L 24 V CC 2^e étage
1+/L 24 V CC 1^{er} étage
-/N 0 V

* Module surveillé en haut et en bas : (max. 2)

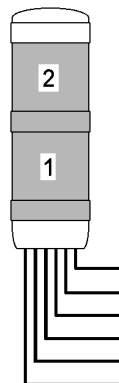

5+/L Contact d'alarme 2, module 1
4+/L Contact d'alarme 1, contact d'alarme commun
1
3+/L Contact d'alarme 2, module 2
2+/L 24 V CC, 2^e étage
1+/L 24 V CC, 1^{er} étage
-/N 0 V

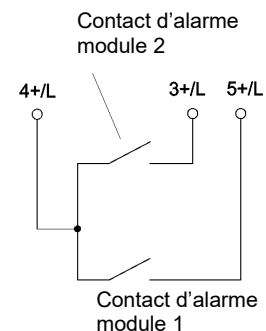

5.4 Module de sirène BR 50-SM

 Le déclenchement soudain de la sirène peut effrayer le personnel.

Caractéristiques, voir [BR 50-SM](#).



Tableau des tonalités

2			109		
16			110		
29			131		
35			146		
56*			167		

* Réglage d'usine

5.5 Module de sirène BR 50-SM HO

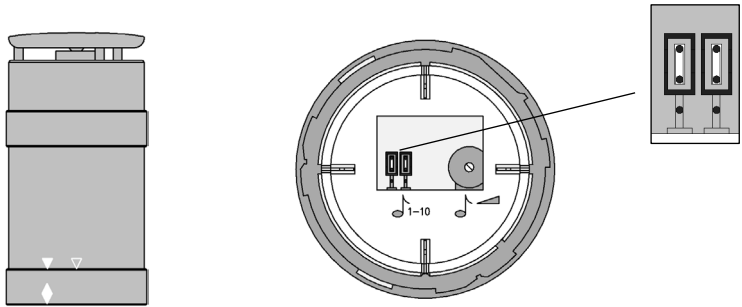

Une activation soudaine du son peut provoquer des réactions de surprise.

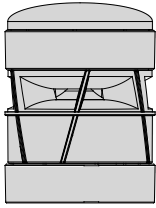

Le module sonore BR 50-SM HO peut être utilisé comme module acoustique en complément de la tour de signalisation Intense BR 50. Ce module permet de sélectionner l'un des 31 sons différents et de régler le volume. Le module BR 50-SM HO doit toujours être installé en position supérieure.

Caractéristiques, voir [BR 50-SM HO](#).

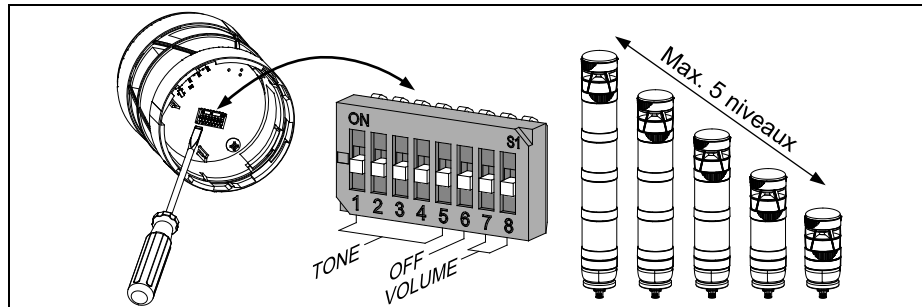

S1 (DIP1)		Volume
7	8	dB
		max. *
ON		-7
	ON	-13
ON	ON	-20

*Paramètres d'usine

Selector switch S1 (DIP1) (Adjusting the base tone)						Tone-No. (J')
1	2	3	4	5	6	
					OFF	162*
ON					OFF	2
	ON				OFF	9
ON	ON				OFF	15
		ON			OFF	18
ON		ON			OFF	22
	ON	ON			OFF	24
ON	ON	ON			OFF	26
			ON		OFF	27
ON			ON		OFF	29
	ON		ON		OFF	36
ON	ON		ON		OFF	54
		ON	ON		OFF	56
ON		ON	ON		OFF	60
	ON	ON	ON		OFF	63
ON	ON	ON	ON		OFF	71
				ON	OFF	82
ON				ON	OFF	83
	ON			ON	OFF	100
ON	ON			ON	OFF	102
		ON		ON	OFF	103
ON		ON		ON	OFF	104
	ON	ON		ON	OFF	112
ON	ON	ON		ON	OFF	123
			ON	ON	OFF	130
ON			ON	ON	OFF	131
	ON		ON	ON	OFF	146
ON	ON		ON	ON	OFF	160
		ON	ON	ON	OFF	161
ON		ON	ON	ON	OFF	163
	ON	ON	ON	ON	OFF	164
ON	ON	ON	ON	ON	OFF	1

5.6 Module AS-i

Toujours utiliser le module AS-i à la position la plus basse :

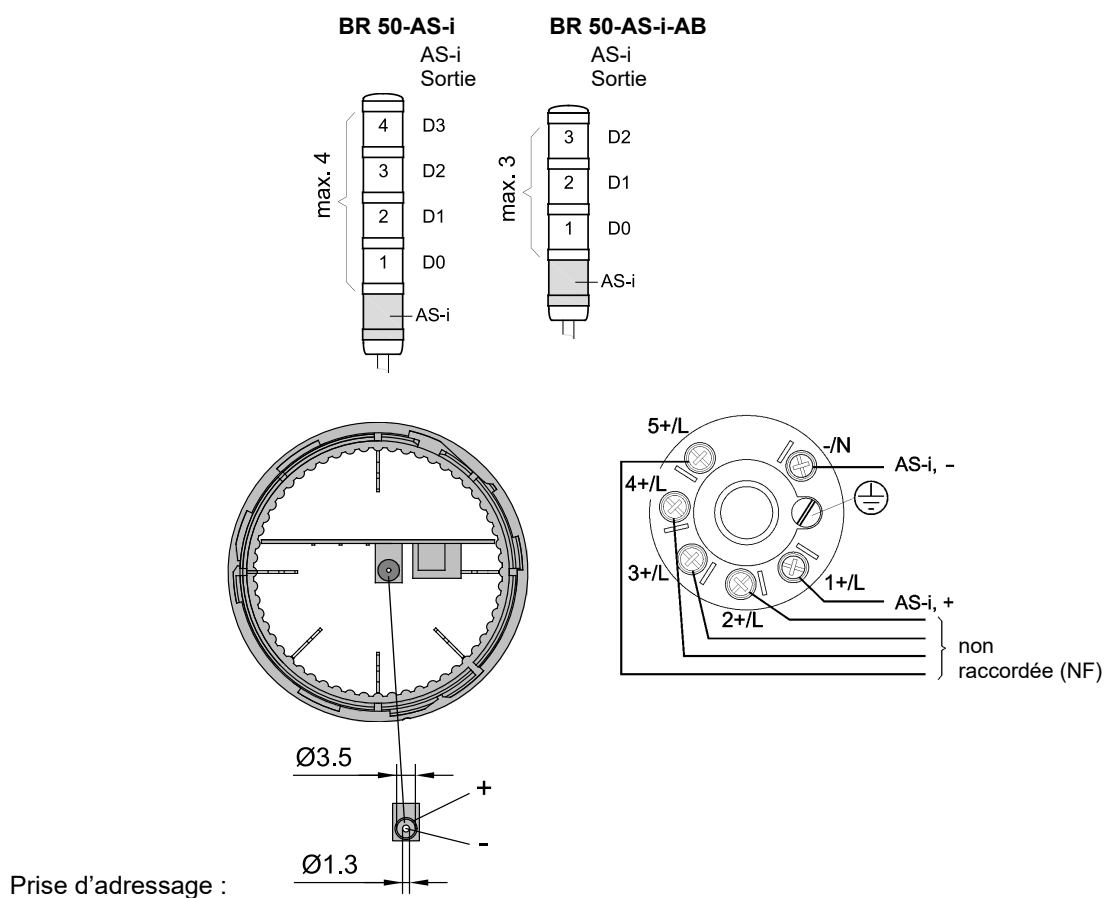

Données techniques

	BR 50-AS-i	BR 50-AS-i-AB
Tension nominale	26,5 V... 31,6 V	
Consommation de courant nominale max.	285 mA	
Nombre maximal d'étages	4	3
Type d'étages	Modules à DEL, module sirène BR 50-SM	
Courant de sortie total Σ :	275 mA	
Spécification AS-i	AS-i 3.0 / EN 50295	
Profil AS-i	S-8.F.E	S-8.A.E
Configuration E/S / configuration [HEX]	8	
Code ID [HEX]	F.E	A.E
Nombre max. d'esclaves par maître	31	62
Adresse de livraison	0	

6. Possibilités de montage

Kit de montage direct BR 50-BG

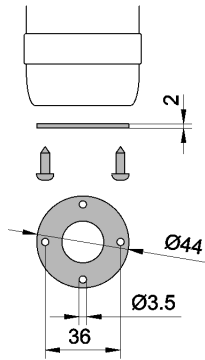

Réf. : 28250210000

Tube avec équerre BR 50-T###

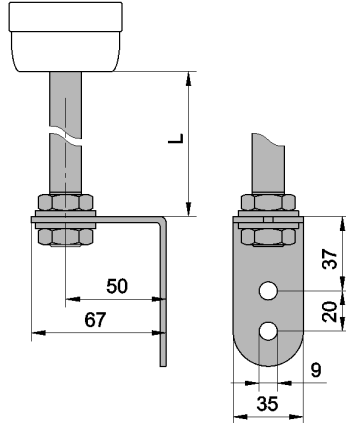

L [mm]
 BR 50-T100 62,5 Réf. : 28250160010
 BR 50-T250 212,5 Réf. : 28250160020
 BR 50-T400 362,5 Réf. : 28250160040

Montage sur trépied BR 50-S###

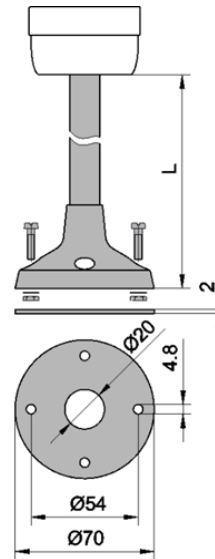

L [mm]
 BR 50-S100 97,5
 BR 50-S250 237,5
 BR 50-S400 387,5

Réf. : 28250150010
 Réf. : 28250150020
 Réf. : 28250150040

Montage direct avec décharge de traction
 BR 50-BC-SR

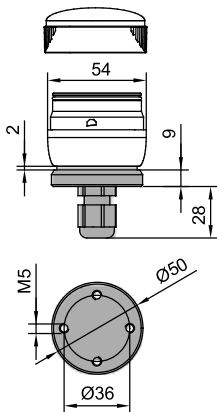

Réf. : 28250280000

Montage sur trépied avec décharge de traction
 BR 50-BC-Sxxx-SR

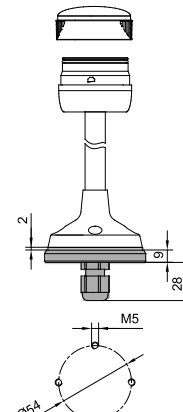

Réf. : 28250290000

Joint de surface
 inclus dans la
 livraison.

Équerre pour montage direct BR 50-
 W (VA)

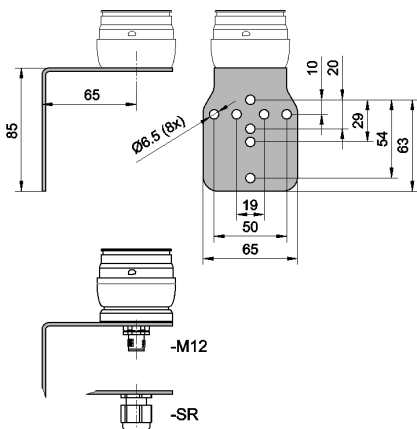

Réf. : 28250180000
 Dimensions en mm.

Lors du montage, employer du matériel de fixation approprié.

Équerre pour montage sur trépied
 BR 50-W (VA)

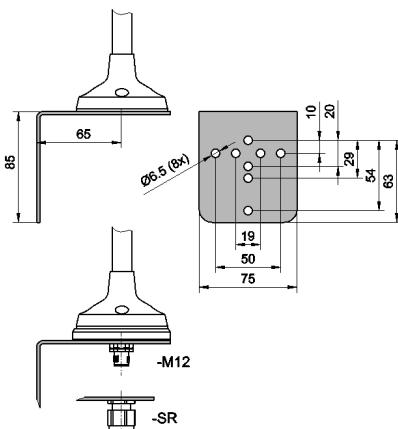

Réf. : 28250190000

Équerre pour montage sur trépied
 BR 50-W (plastique)

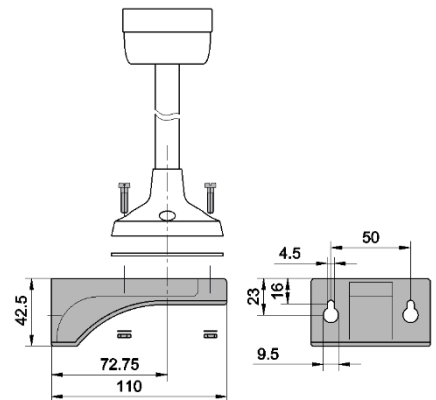

Réf. : 28250200000

7. Données techniques

7.1 Généralités

Nombre de modules (total)	max. 5	
Température de service	-25 °C... +50 °C	
Température de stockage	-40 °C... +70 °C	
Type de protection	IP 54 (EN 60529) extensible en option à IP 65 (Exception: voir chapitre 5.4 Module de sirène BR 50-SM)	
Matériau	Module lumineux :	Polycarbonate (PC)
	Module de terminaison de base, équerre murale trépied (BR 50-S)	Acrylonitrile-butadiène-styrène (ABS)
	Équerre (montage direct, sur trépied) Tube avec équerre (BR 50-T###) :	Acier inoxydable (VA)

7.2 Données électriques

	Couleur de la DEL	recommandé pour la couleur du module...	Tension nominale	Plage de fonctionnement	Consommation de courant nominale max.		Réf.
					CA	CC	
Insert à DELBA 15d <u>Feu fixe</u>	blanc	WH, BU, AM	24 V CA/CC	10... 30 V CA/CC	114 mA	85 mA	28213000102
	jaune	YE			171 mA	85 mA	28213000099
	rouge	RD			121 mA	85 mA	28213000100
	vert	GN			113 mA	85 mA	28213000101
	blanc	WH, BU, AM	115 V CA	+/- 10 %	22 mA	--	28213000118
	jaune	YE			22 mA	--	28213000115
	rouge	RD			26 mA	--	28213000116
	vert	GN			24 mA	--	28213000117
	blanc	WH, BU, AM	230 V CA	220... 240 V CA	22 mA	--	28213000106
	jaune	YE			19 mA	--	28213000103
	rouge	RD			21 mA	--	28213000104
	vert	GN			22 mA	--	28213000105
Insert à DEL BA 15d <u>Feu clignotant (1 Hz)</u>	blanc	WH, BU, AM	24 V CA/CC	10... 30 V CA/CC	57 mA	58 mA	28213000110
	jaune	YE			86 mA	51 mA	28213000107
	rouge	RD			61 mA	37 mA	28213000108
	vert	GN			57 mA	53 mA	28213000109
	blanc	WH, BU, AM	115 V CA	+/- 10 %	22 mA	--	28213000122
	jaune	YE			22 mA	--	28213000119
	rouge	RD			26 mA	--	28213000120
	vert	GN			24 mA	--	28213000121
	blanc	WH, BU, AM	230 V CA	220... 240 V CA	11 mA	--	28213000114
	jaune	YE			10 mA	--	28213000111
	rouge	RD			11 mA	--	28213000112
	vert	GN			11 mA	--	28213000113

	Tension nominale	Plage de fonctionnement	Consommation de courant nominale		Énergie du flash	Énergie du flash
			CA	CC		
Flash BR 50-FL (xénon)	24 V CA/CC	10... 27 V CA 10... 35 V CC	100 mA		1 J	env. 1 Hz
	115 V CA	-10... +15 %	20 mA	--	0,6 J	
	230 V CA	-10... +15 %	10,5 mA	--	0,6 J	





	Tension nominale	Plage de fonctionnement	CA	CC	Niveau sonore max.	Tonalités
Module de sirène BR 50-SM	24 V CC	-10... +20 %	--	12 mA	87 dB (A) Possibilité de réduction : -10 dB(A)	10
	115 V CA	-10... +10 %	15 mA	--		
	230 V CA	-10... +10 %	15 mA	--		

	Tension nominale	Plage de fonctionnement	CA	CC	Niveau sonore max.	Tonalités
BR 50-SM HO	24V DC	-10 ... +20%	--	31 mA	96 dB	31

Module surveillé BR 50-M	Caractéristiques, voir 5.3 Module à DEL surveillé – BR 50-DEL-M					
-----------------------------	---	--	--	--	--	--



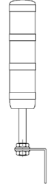

BR 50 AS-i	Caractéristiques, voir 5.6 Module AS-i					
------------	--	--	--	--	--	--

7.3 Dimensions

Hauteur totale des modules assemblés Hauteur totale avec module de sirène : + 21 mm							
Diamètre : Ø 54 mm 							
	Montage sur trépied BR 50-S### 			Montage sur tube BR 50-Txxx 			Montage direct 
Nombre de modules de signalisation	Longueur du tube			Longueur du tube			-
	100	250	400	100	250	400	
1	183	333	483	209	359	509	107
2	246	396	546	272	422	572	170
3	309	459	609	335	485	635	233
4	372	522	672	398	584	698	296
5	435	585	735	461	611	761	359

Dimensions en mm

8. Accessoires

Description	Référence		
Outil d'extraction de bulbe	28250250000		Simplifie l'installation de la source lumineuse
Joint de module pour IP 65	28250220000		1 par module plus 1 pour le module de base (BR 50-BC..)
Joint de tube pour IP 65	28250230000		pour montage sur trépied ou sur tube
Insert à DEL pour modules Flexi <u>Feu fixe</u>	Voir 7.2 Données électriques		
Insert à DEL pour modules Flexi <u>Feu clignotant</u>			
Kit de montage direct BR 50-BG	28250210000		
Tube avec équerre BR 50-T100 Tube avec équerre BR 50-T250 Tube avec équerre BR 50-T400	28250160010 28250160020 28250160040		
Tube montage sur trépied BR 50-S100	28250150010 28250150020 28250150040		Voir chapitre 6. Possibilités de montage
Équerre montage direct (VA) BR 50-W	28250180000		
Équerre pour montage sur trépied (VA) BR 50-W	28250190000		
Équerre pour montage sur trépied (plastique) BR 50-W	28250200000		

9. Maintenance, entretien, réparation

- Pendant tous les travaux sur l'appareil, observer les [Consignes de sécurité](#).

L'appareil ne nécessite aucune maintenance particulière.

- Procéder uniquement au nettoyage extérieur à l'aide d'une solution légèrement savonneuse, sans solvant.
- Pour le nettoyage, ne pas employer d'outils à arêtes vives, veiller notamment à ne pas rayer le capot lumineux.
- Ne pas employer de nettoyeur haute pression.
- Tous les composants doivent être remplacés uniquement par des pièces d'origine.
- Les réparations doivent en principe être effectuées dans les ateliers du fabricant.

Toute transformation, modification, utilisation incorrecte ou interdite ainsi que le non-respect des instructions de service entraînent une exclusion de garantie.

10. Mise hors service, démontage et élimination

- Pendant tous les travaux sur l'appareil, observer les [Consignes de sécurité](#).

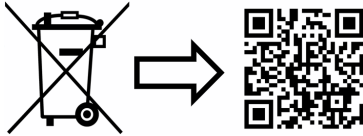

www.pfannenberg.com/disposal



Pfannenberg 
ELECTRO-TECHNOLOGY FOR INDUSTRY

Pfannenberg GmbH

Werner-Witt-Strasse 1 · D-21035 Hamburg (Hambourg)

Tél. : +49/ (0)40/ 734 12-0

Fax : +49/ (0)40/ 734 12-101

service@pfannenberg.com

<http://www.pfannenberg.com>

Contenuto

1. Utilizzo conforme alle disposizioni.....	2
2. Istruzioni di sicurezza.....	2
3. Collegamento elettrico modulo base e terminale	3
3.1 BR 50-BC con cavo di collegamento	3
3.2 Collegamento con connettore M12.....	3
4. Montaggio	4
4.1 Inserimento/sostituzione delle lampadine.....	4
4.2 Montaggio dei moduli	4
5. Moduli funzionali:	5
5.1 Easy Module.....	5
5.2 Flexi Module	5
5.3 Modulo LED supervisionato - BR 50-LED-M	6
5.4 Modulo segnalatore acustico BR 50-SM	7
5.5 Modulo segnalatore acustico BR 50-SM HO	8
5.6 Modulo AS-i.....	9
6. Possibilità di montaggio	10
7. Dati tecnici.....	11
7.1 Caratteristiche generali.....	11
7.2 Dati elettrici.....	11
7.3 Dimensioni.....	12
8. Accessori.....	13
9. Manutenzione, assistenza, riparazione	14
10. Messa fuori servizio, smontaggio e smaltimento.....	14

1. Utilizzo conforme alle disposizioni





Le torrette di segnalazione della serie Intense BR 50 servono per la segnalazione ad esempio di indicazioni di pericolo/stato nei settori industriale, commerciale e degli edifici.

I diversi moduli funzionali offrono diverse possibilità di segnalazione come luce continua, luce intermittente o luce flash allo xeno.

L'utilizzo del segnalatore acustico BR 50-SM HO offre inoltre un allarme acustico aggiuntivo.

L'attrezzatura è adatta all'impiego all'aperto e in ambienti chiusi, ma solo per il montaggio fisso.

2. Istruzioni di sicurezza

	<p>PERICOLO - Scosse elettriche letali</p> <p>Le parti sotto tensione e i cavi di collegamento liberi possono generare scosse elettriche causando gravi incidenti.</p> <ul style="list-style-type: none"> - Solo personale autorizzato e con formazione in elettrotecnica è autorizzato a eseguire interventi sui collegamenti elettrici. - Prima del montaggio togliere tensione a tutte le linee in ingresso e metterle in sicurezza in modo che non possano riattivarsi. Accertarsi sempre che non ci sia tensione. - BR 50-FL: Attendere 2 minuti affinché i componenti elettrici siano privi di tensione. Solo allora aprire il dispositivo. - È possibile riattivare la tensione operativa solo con l'alloggiamento perfettamente chiuso.
	<p>AVVERTENZA - Pericolo per uso non conforme</p> <ul style="list-style-type: none"> - L'uso non conforme dell'apparecchio può causare gravi incidenti. - Utilizzare l'attrezzatura solo se non danneggiata e nel rispetto delle specifiche del cliente. - Il funzionamento dell'apparecchio è garantito solo se i moduli funzionali sono montati in modo corretto. - L'apparecchio è progettato per installazioni fisse.
	<p>PERICOLO - Pericolo per danneggiamento dell'apparecchio</p> <ul style="list-style-type: none"> - Durante le operazioni di installazione e manutenzione dell'apparecchio osservare sempre i dati riportati sulla targhetta identificativa.
	<p>ATTENZIONE - Pericolo di lesioni per bordi taglienti o parti calde</p> <ul style="list-style-type: none"> - Durante le operazioni di installazione, montaggio o assistenza/manutenzione indossare dispositivi di protezione individuale (DPI) adatti. - Realizzare i collegamenti lontano da bordi taglienti, spigoli o componenti interni, ed evitare di urtare contro componenti.
	<p>ATTENZIONE - Compromissione di vista</p> <ul style="list-style-type: none"> - per non compromettere la vista, evitare di rivolgere lo sguardo direttamente alla luce continua attiva. - BR 50-FL: L'improvvisa attivazione del lampeggio può causare reazioni di spavento.

3. Collegamento elettrico modulo base e terminale

3.1 BR 50-BC con cavo di collegamento

12 – 230 V

Collegamento mediante cavo:
Coppia 0,6 Nm

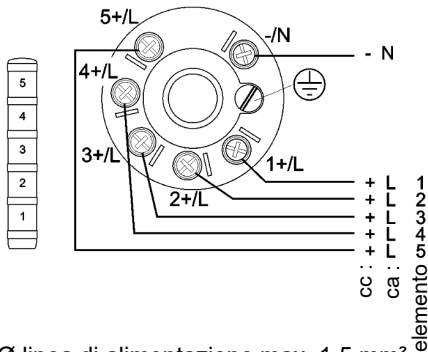

Terminale di messa a terra
Coppia 0,6 Nm

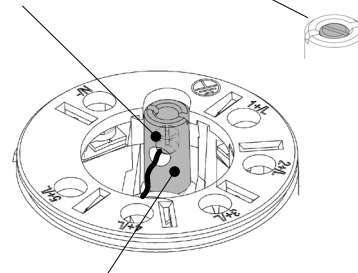

In caso di montaggio su tubo o piedistallo (opzionale):
Allentare la vite esterna, montare il tubo e riserrare a fondo la vite
Coppia: 1,5 Nm

Ø linea di alimentazione max. 1,5 mm²
capocorda tubolare 8mm

 115/ 230V ca in caso di montaggio su piedistallo o tubo:
Realizzare il collegamento elettrico con un cavo inguainato.

BR 50-BC

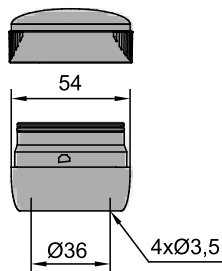

P/N: 28250010000

3.2 Collegamento con connettore M12

12 – 24 V ca/cc

BR 50-BC-M12

BR 50-BC-Sxxx-M12

Connettore M12

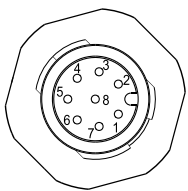

Collegamento
BR 50-
elemento ..

1	1 / +
2	2 / +
3	3 / +
4	4 / +
5	5 / +
6	/
7	- (COM)
8	/

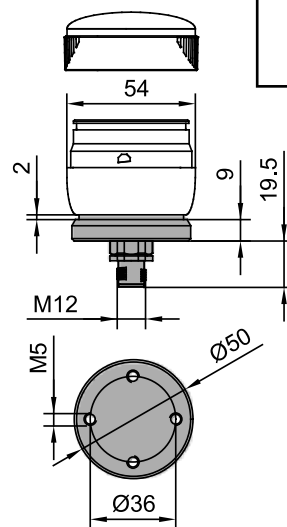

Guarnizione di
superficie inclusa
nella fornitura.

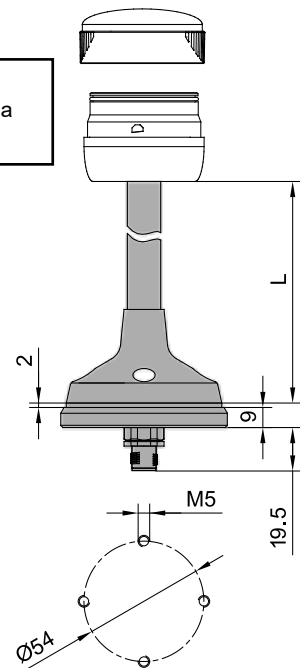

P/N: 28250126000

P/N: 28250126010 97,5
P/N: 28250126020 237,5
P/N: 28250126040 387,5
L [mm]

4. Montaggio

4.1 Inserimento/sostituzione delle lampadine

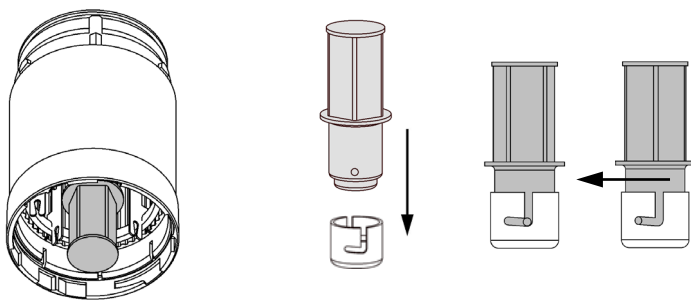

Per una facile manipolazione durante la sostituzione di una lampadina, è possibile utilizzare il Flexi-Tool come accessorio, vedi [Flexi Tool](#).

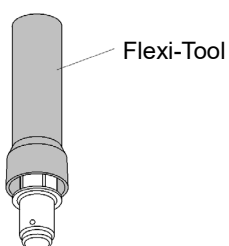

4.2 Montaggio dei moduli

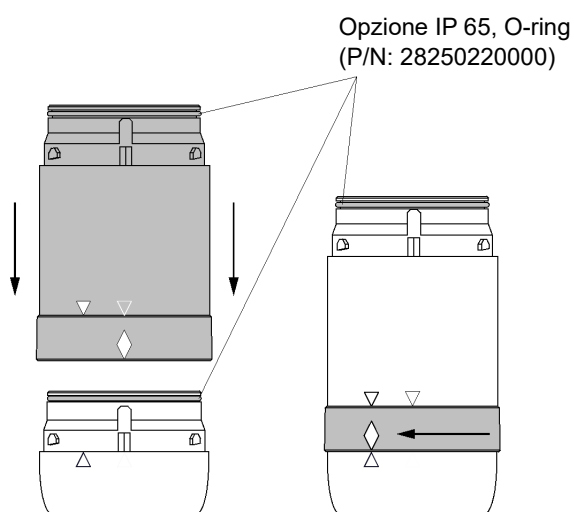

Montaggio O-ring IP 65 (P/N: 28250230000)
per montaggio su piedistallo o tubo

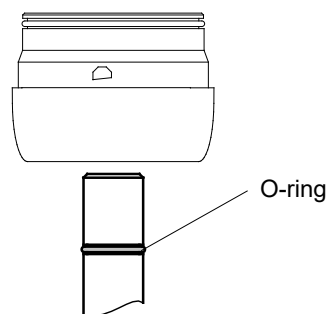

5. Moduli funzionali:

5.1 Easy Module

Il modulo è dotato di una sorgente luminosa già montata.

Fully Coloured Module



RD



YE



AM



GN



BU



CL

		Tensione		
Modulo colorato P/N: 2825037*	dotato di inserto LED (luce continua) Colori LED: bianco, rosso, giallo, verde	24 V ca/cc	230 V ca	115 V ca
		Per i dati, vedi 7.2 Dati elettrici		
Modulo colorato P/N: 2825007xx#0 xx: 10=230V AC, 16=115V AC, 80=24VAC/DC #: 1-CL, 3-YE, 4-AM, 5-RD, 6-GN, 7-BU	dotato di tubi lampeggianti allo xeno	24 V ca/cc	230 V ca	115 V ca
		Per i dati, vedi BR50 FL		

Crystal Clear Module

Colore dei LED		
RD	YE	GN
CL	CL	CL
Colore del modulo		

		Tensione		
Modulo chiaro P/N: 2825037xx1# xx: 10=230V AC, 16=115V AC, 60=24VAC/DC #: 1-CL, 3-YE, 4-AM, 5-RD, 6-GN, 7-BU	dotato di inserto LED (luce continua) Colori LED: rosso, giallo, verde	24 V ca/cc	230 V ca	115 V ca
		Per i dati, vedi 7.2 Dati elettrici		

5.2 Flexi Module

Modulo vuoto, i seguenti inserti sono disponibili separatamente:

Fully Coloured Module



RD



YE



AM



GN



BU



CL

		Tensione		
Modulo colorato P/N: 282500400#0 #: 1-CL, 3-YE, 4-AM, 5-RD, 6-GN, 7-BU	Inserto LED: Luce continua	Per i dati, vedi 7.2 Dati elettrici		
	Inserto LED: Luce intermittente			

5.3 Modulo LED supervisionato - BR 50-LED-M

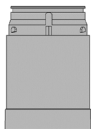

Il modulo LED con monitoraggio del funzionamento per la torretta di segnalazione Intense BR 50 può essere utilizzato in combinazione con altri moduli funzionali ad es. per applicazioni rilevanti per la sicurezza. Il canale diagnostico del modulo (contatto di allarme) può essere integrato in un sistema di comando superiore come feedback.

Si possono utilizzare fino a 3 moduli. *

Tensione nominale	24 V cc
Range di funzionamento	21,6 V – 26,4 V cc
Corrente nominale	35 mA
Uscita allarme	1 ——— 2 Max. 230 V ca/cc / 80 mA $R_{ON\ max}$ 35 Ohm chiusa in caso di funzionamento privo di anomalie

Modulo supervisionato in alto:

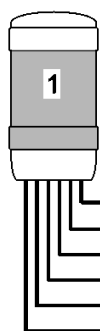

5+/L NC (not connected)
4+/L NC (not connected)
3+/L Contatto allarme 2
2+/L Contatto allarme 1
1+/L 24V cc
-/N 0V

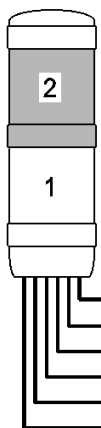

5+/L NC (not connected)
4+/L Contatto allarme 2
3+/L Contatto allarme 1
2+/L 24V cc 2° elemento
1+/L 24V cc 1° elemento
-/N 0V



5+/L Contatto allarme 2
4+/L Contatto allarme 1
3+/L 24V cc 3° elemento
2+/L 24V cc 2° elemento
1+/L 24V cc 1° elemento
-/N 0V

Modulo supervisionato in basso:

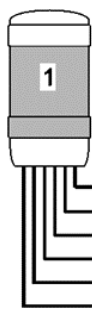

5+/L Contatto allarme 2
4+/L Contatto allarme 1
3+/L NC (not connected)
2+/L NC (not connected)
1+/L 24V cc
-/N 0V

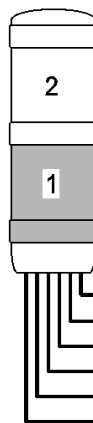

5+/L Contatto allarme 2
4+/L Contatto allarme 1
3+/L NC (not connected)
2+/L 24V cc 2° elemento
1+/L 24V cc 1° elemento
-/N 0V



5+/L Contatto allarme 2
4+/L Contatto allarme 1
3+/L 24V cc 3° elemento
2+/L 24V cc 2° elemento
1+/L 24V cc 1° elemento
-/N 0V

*
Modulo supervisionato
in alto e in basso:
(max. 2)

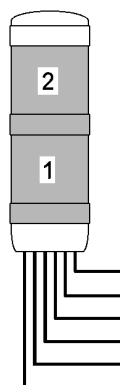

5+/L Contatto allarme 2, modulo 1
4+/L Contatto allarme 1, contatto allarme congiunto 1
3+/L Contatto allarme 2, modulo 2
2+/L 24V cc, 2° elemento
1+/L 24V cc, 1° elemento
-/N 0V

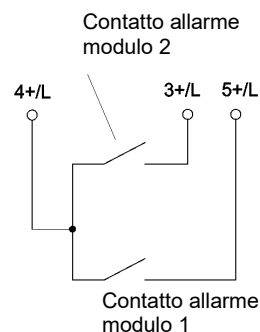

5.4 Modulo segnalatore acustico BR 50-SM



L'improvvisa attivazione del segnale acustico può causare reazioni di spavento.

Per i dati, vedi [BR 50-SM](#).



Tabella toni

2			109		
16			110		
29			131		
35			146		
56*			167		

* Impostazione di fabbrica

5.5 Modulo segnalatore acustico BR 50-SM HO

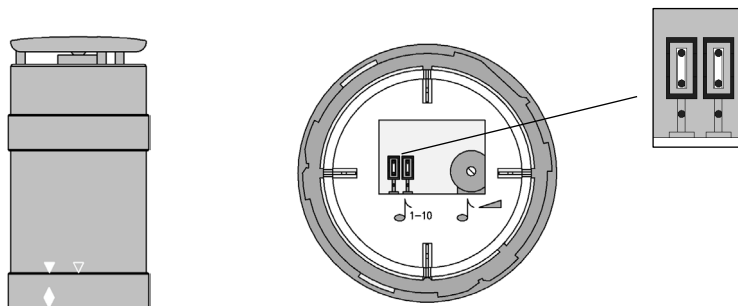

L'attivazione improvvisa del suono può causare reazioni di spavento.

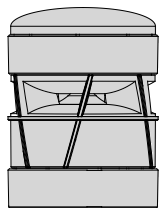

Il modulo acustico BR 50-SM HO può essere utilizzato come modulo sonoro in aggiunta alla colonna di segnalazione Intense BR 50. Il modulo consente di selezionare uno dei 31 suoni disponibili e di regolare il volume. Il modulo BR 50-SM HO deve essere sempre installato nella posizione superiore.

Per i dati, vedi [BR 50-SM HO](#).

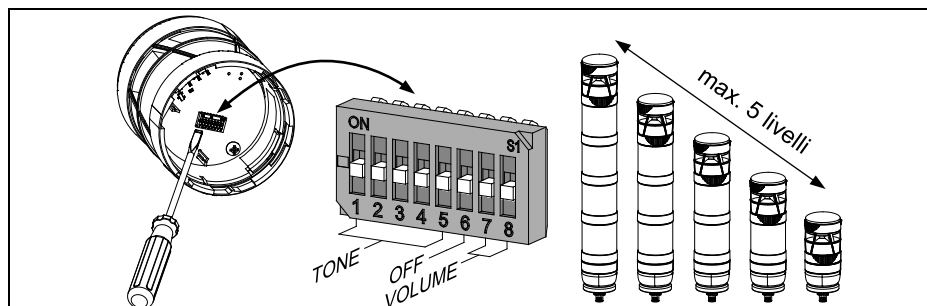

S1 (DIP1)		Volume
7	8	dB
		max. *
ON		-7
	ON	-13
ON	ON	-20

* Impostazione di fabbrica

Selector switch S1 (DIP1) (Adjusting the base tone)						Tone-No. (J')
1	2	3	4	5	6	
					OFF	162*
ON					OFF	2
	ON				OFF	9
ON	ON				OFF	15
		ON			OFF	18
ON		ON			OFF	22
	ON	ON			OFF	24
ON	ON	ON			OFF	26
			ON		OFF	27
ON			ON		OFF	29
	ON		ON		OFF	36
ON	ON		ON		OFF	54
		ON	ON		OFF	56
ON		ON	ON		OFF	60
	ON	ON	ON		OFF	63
ON	ON	ON	ON		OFF	71
				ON	OFF	82
ON				ON	OFF	83
	ON			ON	OFF	100
ON	ON			ON	OFF	102
		ON		ON	OFF	103
ON		ON		ON	OFF	104
	ON	ON		ON	OFF	112
ON	ON	ON		ON	OFF	123
			ON	ON	OFF	130
ON			ON	ON	OFF	131
	ON		ON	ON	OFF	146
ON	ON		ON	ON	OFF	160
		ON	ON	ON	OFF	161
ON		ON	ON	ON	OFF	163
	ON	ON	ON	ON	OFF	164
ON	ON	ON	ON	ON	OFF	1

5.6 Modulo AS-i

Utilizzare sempre il modulo AS-i nella posizione inferiore:

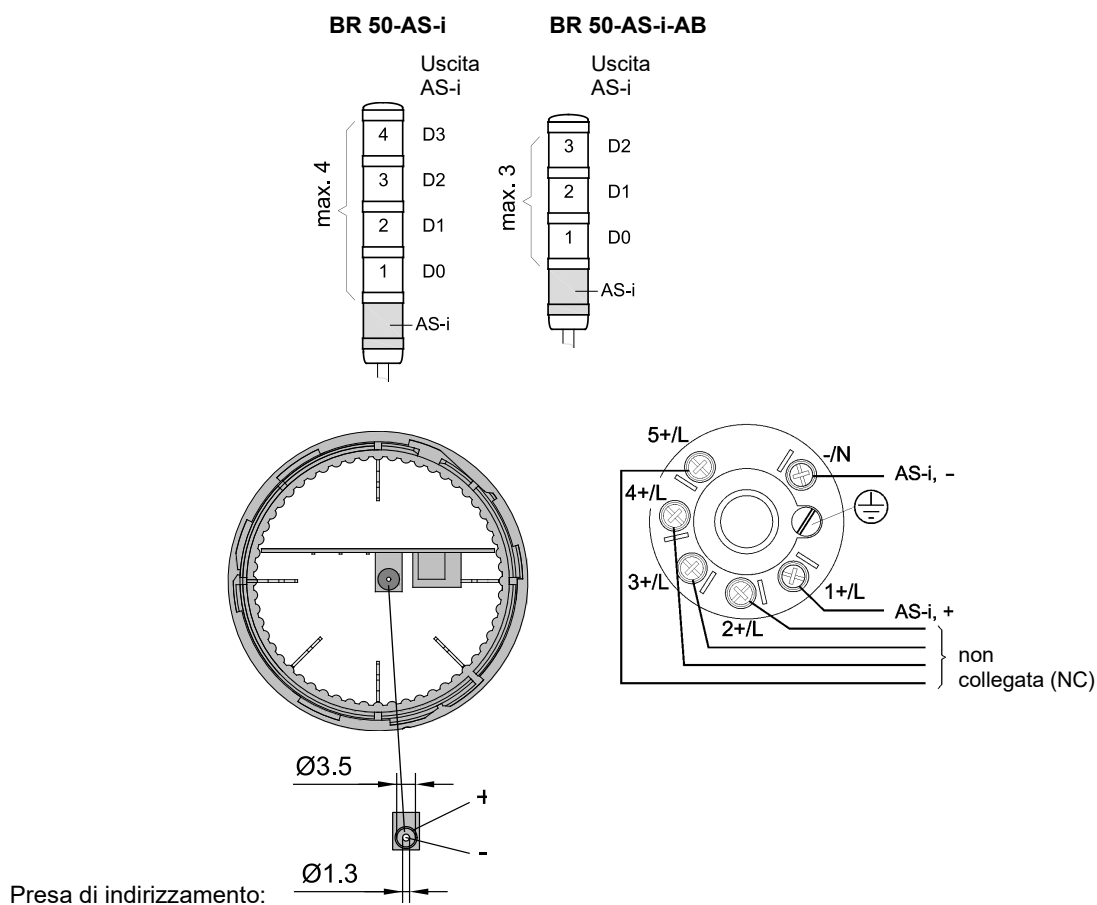

Dati tecnici:

	BR 50-AS-i	BR 50-AS-i-AB
Tensione nominale	26,5 V .. 31,6 V	
Consumo di corrente nominale max.	285 mA	
Numero massimo di elementi	4	3
Tipo di elementi	Moduli LED, modulo segnalatore acustico BR 50-SM	
Corrente di uscita totale Σ :	275 mA	
Specifica AS-i	AS-i 3.0 / EN 50295	
Profilo AS-i	S-8.F.E	S-8.A.E
Configurazione I/O / configuration [HEX]	8	
Codice ID [HEX]	F.E	A.E
Numero max. di slave per master	31	62
Indirizzo di consegna	0	

6. Possibilità di montaggio

Set di montaggio diretto BR 50-BG

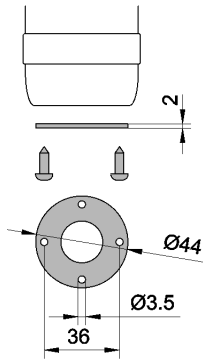

P/N: 28250210000

Tubo con staffa angolare BR 50-T###

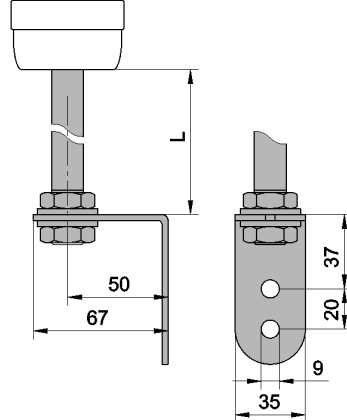

	L [mm]	P/N:
BR 50-T100	62,5	28250160010
BR 50-T250	212,5	28250160020
BR 50-T400	362,5	28250160040

Montaggio su piedistallo BR 50-S###

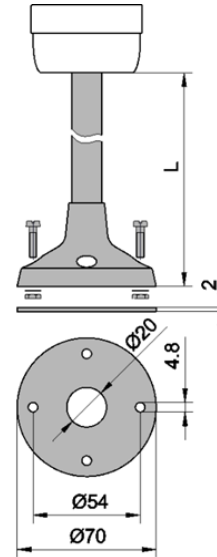

	L [mm]
BR 50-S100	97,5
BR 50-S250	237,5
BR 50-S400	387,5

P/N: 28250150010
P/N: 28250150020
P/N: 28250150040

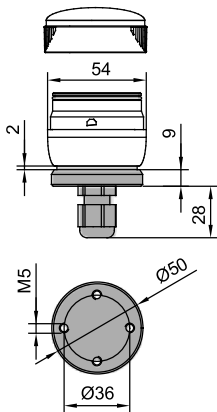
Montaggio diretto con scarico della trazione
BR 50-BC-SR

P/N: 28250280000

Guarnizione di
superficie inclusa
nella fornitura.

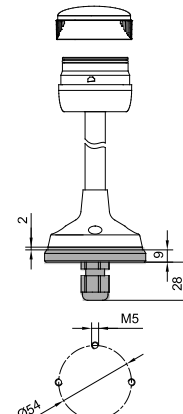
Montaggio su treppiede con scarico della trazione
BR 50-BC-Sxxx-SR

P/N: 28250290000

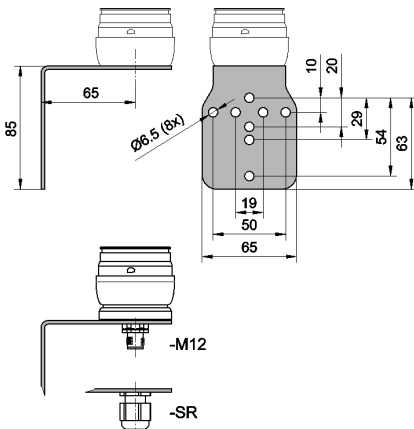
Staffa angolare per montaggio
diretto BR 50-W (VA)

P/N: 28250180000

Dimensioni in mm.

Per il montaggio si deve utilizzare materiale di fissaggio adatto.

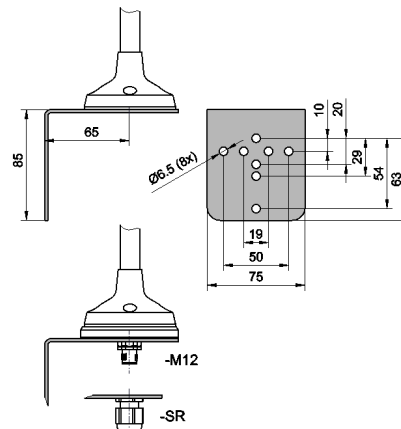
Staffa angolare per montaggio su
pedistallo BR 50-W (VA)

P/N: 28250190000

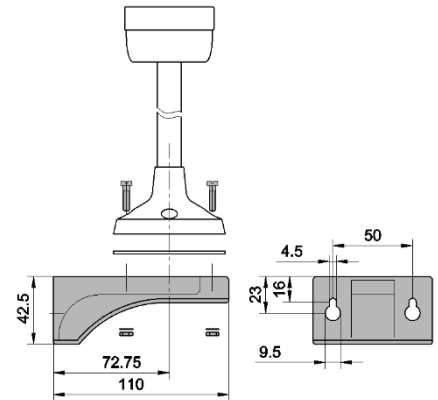
Staffa angolare per montaggio su
pedistallo BR 50-W (plastica)

P/N: 28250200000

7. Dati tecnici

7.1 Caratteristiche generali

Numero moduli (totale)	max. 5	
Temperatura d'esercizio	-25 °C .. +50 °C	
Temperatura di stoccaggio	-40 °C .. +70 °C	
Grado di protezione	IP 54 (EN 60529) ampliabile opzionalmente a IP 65 (Eccezione: Vedi capitolo 5.4 Modulo segnalatore acustico BR 50-SM)	
Materiale	Modulo luminoso: Modulo base/terminale, staffa a parete piedistallo (BR 50-S) Staffa angolare (montaggio diretto, su piedistallo) Tubo con staffa angolare (BR 50-T###):	Polycarbonato (PC) Acrilonitrile butadiene stirene (ABS) Acciaio inossidabile (VA)

7.2 Dati elettrici

	Colore dei LED	Raccomandato per colore modulo...	Tensione-nominale	Range di funzionamento	Consumo di corrente nominale max.		P/N
					CA	CC	
Inserito LEDBA 15d <u>Luce continua</u>	bianco	WH, BU, AM	24V ca/cc	10 .. 30V ca/cc	114 mA	85 mA	28213000102
	giallo	YE			171 mA	85 mA	28213000099
	rosso	RD			121 mA	85 mA	28213000100
	verde	GN			113 mA	85 mA	28213000101
	bianco	WH, BU, AM	115 V ca	+/- 10%	22 mA	--	28213000118
	giallo	YE			22 mA	--	28213000115
	rosso	RD			26 mA	--	28213000116
	verde	GN			24 mA	--	28213000117
	bianco	WH, BU, AM	230 V ca	220 .. 240V ca	22 mA	--	28213000106
	giallo	YE			19 mA	--	28213000103
	rosso	RD			21 mA	--	28213000104
	verde	GN			22 mA	--	28213000105

Inserito LED BA 15d <u>Luce intermittente (1 Hz)</u>	bianco	WH, BU, AM	24V ca/cc	10 .. 30V ca/cc	57 mA	58 mA	28213000110
	giallo	YE			86 mA	51 mA	28213000107
	rosso	RD			61 mA	37 mA	28213000108
	verde	GN			57 mA	53 mA	28213000109
	bianco	WH, BU, AM	115 V ca	+/- 10%	22 mA	--	28213000122
	giallo	YE			22 mA	--	28213000119
	rosso	RD			26 mA	--	28213000120
	verde	GN			24 mA	--	28213000121
	bianco	WH, BU, AM	230 V ca	220 .. 240V ca	11 mA	--	28213000114
	giallo	YE			10 mA	--	28213000111
	rosso	RD			11 mA	--	28213000112
	verde	GN			11 mA	--	28213000113

	Tensione nominale	Range di funzionamento	Consumo di corrente nominale		Energia flash	Energia flash
			CA	CC		
Luce flash BR 50-FL (xeno)	24V ca/cc	10 .. 27V ca 10 .. 35V cc	100 mA		1 J	ca. 1 Hz
	115 V ca	-10 .. +15%	20 mA	--	0,6 J	
	230 V ca	-10 .. +15%	10,5 mA	--	0,6 J	





	Tensione nominale	Range di funzionamento	CA	CC	Pressione acustica max.	Toni
Modulo segnalatore acustico BR 50-SM	24V cc	-10 .. +20%		12 mA	87 dB (A) Riducibile: -10 dB(A)	10
	115 V ca	-10 .. +10%	15 mA	--		
	230 V ca	-10 .. +10%	15 mA	--		

	Tensione nominale	Range di funzionamento	CA	CC	Pressione acustica max.	Toni
Modulo segnalatore acustico BR 50-SM HO	24V DC	-10 .. +20%	--	31 mA	96 dB	31

Modulo supervisionato BR 50-M	Per i dati, vedi 5.3 Modulo LED supervisionato - BR 50-LED-M					
-------------------------------	--	--	--	--	--	--



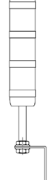

BR 50 AS-i	Per i dati, vedi 5.6 Modulo AS-i					
------------	--	--	--	--	--	--

7.3 Dimensioni

Altezza totale dei moduli montati							
Altezza totale con modulo segnalatore acustico: + 21 mm							
Diametro: Ø 54 mm 							
	Montaggio su piedistallo BR 50-S### 			Montaggio su tubo BR 50-Txxx 			Montaggio diretto 
Numero moduli di segnalazione	Lunghezza tubo			Lunghezza tubo			-
	100	250	400	100	250	400	
1	183	333	483	209	359	509	107
2	246	396	546	272	422	572	170
3	309	459	609	335	485	635	233
4	372	522	672	398	584	698	296
5	435	585	735	461	611	761	359

Dimensioni in mm

8. Accessori

Denominazione	N. art.		
Flexi Tool	28250250000		Semplifica il montaggio della lampadina
Guarnizione modulo per IP 65	28250220000		1x per modulo più 1x per modulo base (BR 50-BC..)
Guarnizione tubo per IP 65	28250230000		per montaggio su piedistallo o tubo
Inserto LED per moduli Flexi <u>Luce continua</u>	Vedi 7.2 Dati elettrici		Vedi capitolo 6. Possibilità di montaggio
Inserto LED per moduli Flexi <u>Luce intermittente</u>			
BR 50-BG Set per montaggio diretto	28250210000		
BR 50-T100 Tubo con staffa angolare BR 50-T250 Tubo con staffa angolare BR 50-T400 Tubo con staffa angolare	28250160010 28250160020 28250160040		
BR 50-S100 Tubo montaggio su piedistallo	28250150010 28250150020 28250150040		
BR 50-W Staffa angolare per montaggio diretto (VA)	28250180000		
BR 50-W Staffa angolare per montaggio su piedistallo (VA)	28250190000		
BR 50-W Staffa angolare per montaggio su piedistallo (plastica)	28250200000		

9. Manutenzione, assistenza, riparazione

- Per l'esecuzione di tutti gli interventi sull'apparecchio osservare le [Istruzioni di sicurezza](#).

L'apparecchio non richiede una particolare manutenzione.

- Pulire le parti esterne solo con una soluzione detergente delicata senza usare solventi.
- Per la pulizia non utilizzare attrezzi appuntiti, in particolare non graffiare la calotta della luce.
- Non pulire con alta pressione.
- Sostituire i componenti con ricambi originali.
- Fare eseguire le riparazioni solo presso il fabbricante.

Interventi, modifiche, interventi errati e non consentiti insieme all'inosservanza delle istruzioni contenute nel presente manuale d'uso rendono nulla la garanzia.

10. Messa fuori servizio, smontaggio e smaltimento

- Per l'esecuzione di tutti gli interventi sull'apparecchio osservare le [Istruzioni di sicurezza](#).

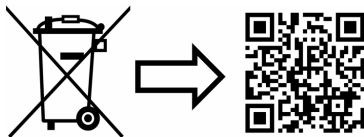

www.pfannenbergl.com/disposal



Содержание

1. Применение по назначению	2
2. Правила техники безопасности	2
3. Электрическое соединение базового оконечного модуля	3
3.1 BR 50-BC с соединительным кабелем	3
3.2 соединение с M12 разъемом	3
4. Монтаж	4
4.1 Вставить/заменить источник света	4
4.2 Монтаж модулей	4
5. Функциональные модули:	5
5.1 Модуль Easy	5
5.2 Модули Flexi	5
5.3 Контролируемый светодиодный модуль - BR 50-LED-M.	6
5.4 Звуковой оповещатель BR 50-SM	7
5.5 Звуковой оповещатель BR 50-SM HO	8
5.6 Модуль AS-i	9
6. Варианты монтажа	10
7. Технические данные	11
7.1 Общие сведения	11
7.2 Электрические данные	11
7.3 Размеры	12
8. Дополнительные принадлежности	13
9. Техническое обслуживание, сервис, поддержание в исправном состоянии	14
10. Вывод из эксплуатации, демонтаж и утилизация	14

1. Применение по назначению





Сигнальные колонки серии Intense BR 50 используются для сигнализации, например, опасности или отображения состояний в промышленных, коммерческих и строительных зонах.

Различные функциональные модули предлагают различные варианты сигнализации, такие как постоянный свет, мигающий свет или Ксеноновая вспышка.

Использование сирены BR 50-SM HO также обеспечивает дополнительный звуковой сигнал.

Устройства предусмотрены для применения внутри и вне помещений и предназначены только для стационарного монтажа.

2. Правила техники безопасности

	<p>ОПАСНОСТЬ - Опасность для жизни в результате поражения электрическим током</p> <p>Находящиеся под напряжением устройства и открытые соединительные линии создают опасность поражения электрическим током и могут вызывать тяжелые несчастные случаи.</p> <ul style="list-style-type: none"> - Работы над подключениями к электросети разрешается выполнять только обученным и авторизованным специалистам-электрикам. - Перед монтажом все подводящие линии необходимо обесточить и заблокировать от повторного включения. Необходимо всегда удостоверяться в отсутствии напряжения. - BR 50-FL Выждать фазу разряда электрических компонентов длительностью в 2 минуты. Лишь затем открывать устройство. - Включение рабочего напряжения должно производиться только при плотно закрытом корпусе.
	<p>ПРЕДОСТЕРЕЖЕНИЕ - Опасность в результате недопустимого применения устройств</p> <ul style="list-style-type: none"> - Применение не по назначению может привести к тяжелым авариям. - Эксплуатировать устройства только в неповрежденном состоянии в пределах указанных параметров. - Функционирование устройства гарантируется только при правильной сборке функциональных узлов. - Устройства предназначены исключительно для стационарного монтажа.
	<p>ОПАСНОСТЬ - Опасность в результате повреждения устройств</p> <ul style="list-style-type: none"> - При установке и техническом обслуживании устройств следует всегда учитывать данные на типовой табличке.
	<p>ВНИМАНИЕ - Опасность травмирования острыми кромками или горячими деталями</p> <ul style="list-style-type: none"> - Используйте подходящие средства индивидуальной защиты (СИЗ) для установки, сборки или обслуживания/технического обслуживания. - Разводку кабелей выполнять вдали от острых кромок, углов и внутренних компонентов, избегать столкновений с компонентами.
	<p>ВНИМАНИЕ - Опасность ухудшения зрения</p> <ul style="list-style-type: none"> - Чтобы не допустить ухудшения зрения, избегать длительного прямого зрительного контакта с включенной лампой. - BR 50-FL: Внезапное срабатывание вспышки может привести к реакциям испуга.

3. Электрическое соединение базового оконечного модуля

3.1 BR 50-BC с соединительным кабелем

12 – 230 В

Подключение кабеля:

Момент затяжки 0,6 Нм

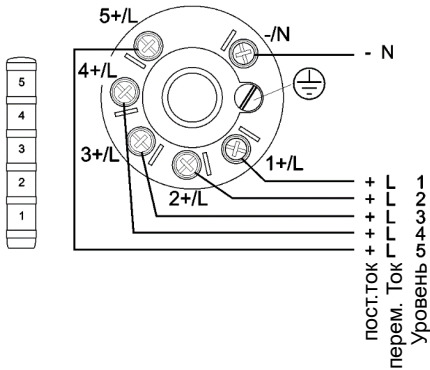

Заземление
Момент затяжки 0,6 Нм:

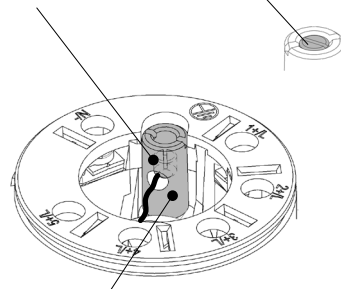

Для крепления на трубе или штативе (опция):
Ослабьте наружный винт, установите трубу и затяните винт еще раз
Момент затяжки: 1,5 Нм

Ø Подводящий провод макс. 1,5 мм²
гильза для провода 8 мм



115/ 230В перем. ток для установки на штатив или трубу:

Выполните электрическое соединение с проводом в оболочке.

BR 50-BC

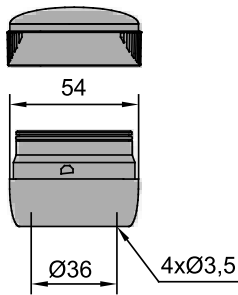

Номер по каталогу: 28250010000

3.2 соединение с M12 разъемом

12 – 24 В перем. ток / пост. ток

BR 50-BC-M12

BR 50-BC-Sxxx-M12

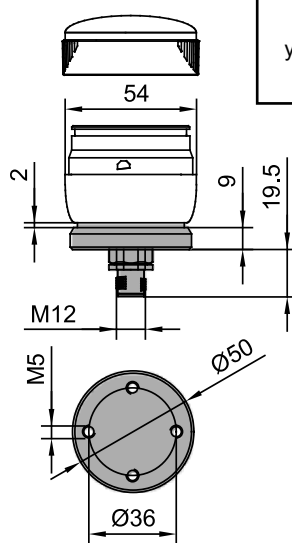
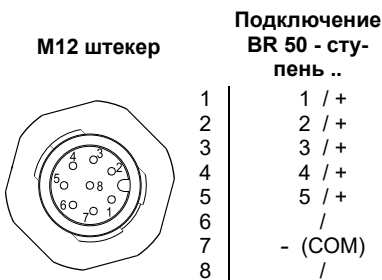

Поверхностное уплотнение входит в комплект по-

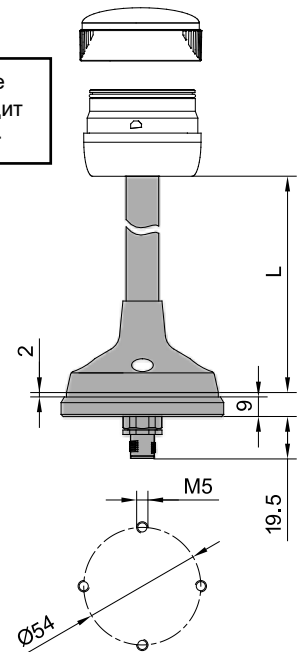

Номер по каталогу: 28250126000

Номер по каталогу: 28250126010 97,5
Номер по каталогу: 28250126020 237,5
Номер по каталогу: 28250126040 387,5
L [mm]

4. Монтаж

4.1 Вставить/заменить источник света

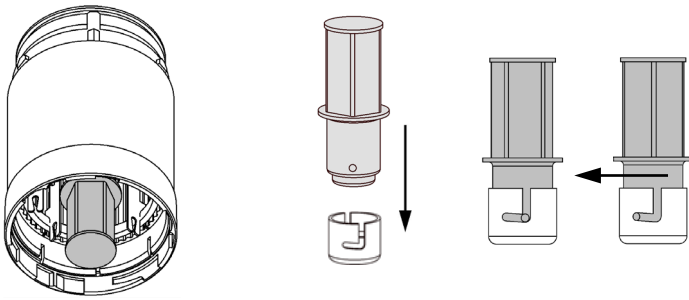

Для облегчения работы при замене источника света можно использовать в качестве принадлежности инструмент Flexi см. [Инструмент Flexi](#).

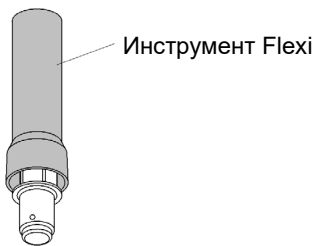

4.2 Монтаж модулей

Опция IP 65, уплотнительное кольцо установка уплотнительного кольца IP 65
(Номер по каталогу: 28250230000)
(Номер по каталогу: 28250220000) для установки на штатив или трубу

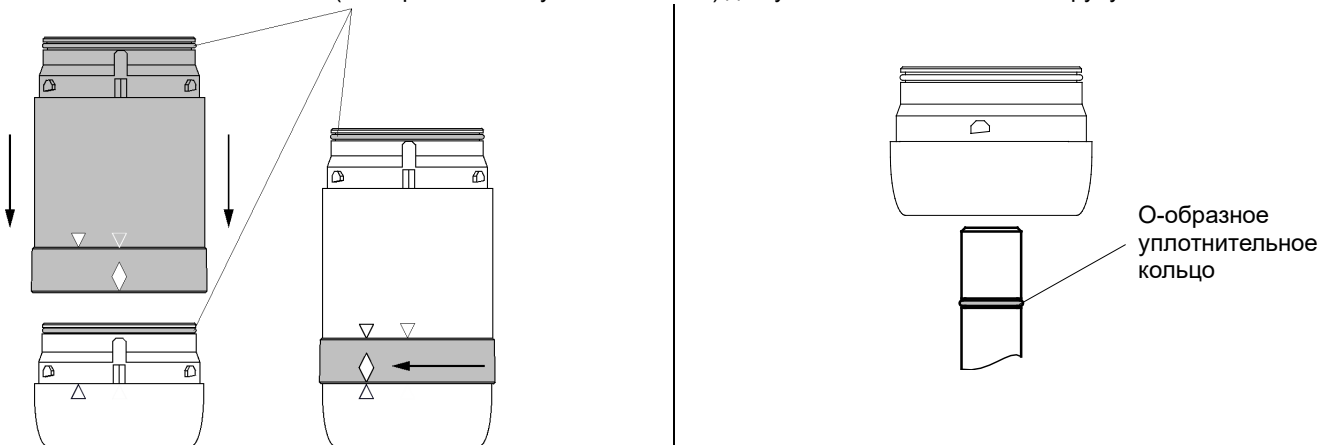

5. Функциональные модули:

5.1 Модуль Easy

Модуль оснащен источником света, который уже установлен.

Fully Coloured Module (Цветные модули)



RD (красный)



YE (желтый)



AM (оранжевый)



GN (зеленый)



BU (синий)



CL (прозрачный)

		Напряжение		
Цветной модуль Номер по каталогу: 2825037*	оснащен светодиодным индикатором (постоянный свет) Цвета светодиодов: белый, красный, желтый, зеленый	24 В перем. ток / пост.ток	230 В перем. ток	115 В перем. ток
		Данные см. в разделе 7.2 Электрические данные		
Цветной модуль Номер по каталогу: 2825007хх#0 хх: 10=230В перем. ток, 16=115В перем. ток, 80=24В перем ток/ пост. ток #: 1-CL, 3-YE, 4-AM, 5-RD, 6-GN, 7-BU	Оборудован ксеноновой лампой-вспышкой	24 В перем. ток / пост.ток	230 В перем. ток	115 В перем. ток
		Данные см. в разделе BR 50-FL		

Модули Crystal Clear

Цвет светодиода		
RD (красный)	YE (желтый)	GN (зеленый)
CL (прозрачный)	CL (прозрачный)	CL (прозрачный)
Цвет модуля		

		Напряжение		
Прозрачный модуль Номер по каталогу: 2825037хх1# хх: 10=230В перем. ток, 16=115В перем. ток, 60=24В перем ток/ пост. ток #: 1-CL, 3-YE, 4-AM, 5-RD, 6-GN, 7-BU	оснащен светодиодным индикатором (постоянный свет) Цвета светодиодов: красный, желтый, зеленый	24 В перем. ток / пост.ток	230 В перем. ток	115 В перем. ток
		Данные см. в разделе 7.2 Электрические данные		

5.2 Модули Flexi

Пустой модуль, следующие вставки доступны отдельно:

Fully Coloured Module (Цветные модули)



RD (красный)



YE (желтый)



AM (оранжевый)



GN (зеленый)



BU (синий)



CL (прозрачный)

		Напряжение		
Цветной модуль Номер по каталогу: 282500400#0 #: 1-CL, 3-YE, 4-AM, 5-RD, 6-GN, 7-BU	Светодиодная вставка: Постоянный свет	Данные см. в разделе 7.2 Электрические данные		
	Светодиодная вставка: Мигающий свет			

5.3 Контролируемый светодиодный модуль - BR 50-LED-M.

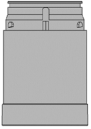

Светодиодный модуль с контролем функций для сигнальной колонки Intense BR 50 можно легко использовать в сочетании с другими функциональными модулями, например, для применения в условиях безопасности. Диагностический канал модуля (контакт сигнализации) может быть интегрирован в систему управления более высокого уровня в качестве обратной связи.

Могут использоваться максимально 3 модуля. *

Номинальное напряжение	24 В пост. ток
Диапазон функционирования	21,6 В – 26,4 В пост. ток
Номинальный ток	35 мА
Выход сигнализации	Макс. 230 В перем./пост. ток / 80 мА $R_{ON\ макс}$ 35 Ом 1 — 2

Контролируемый модуль наверху:

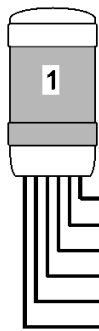

5+/L NC (not connected)
4+/L NC (not connected)
3+/L контакт сигнализации 2
2+/L контакт сигнализации 1
1+/L 24В пост. ток
-/N 0В

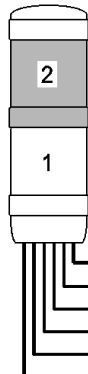

5+/L NC (not connected)
4+/L контакт сигнализации 2
3+/L контакт сигнализации 1
2+/L 24В пост. ток 2. Ступень
1+/L 24В пост. ток 1. Ступень
-/N 0В

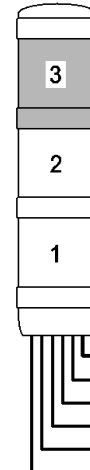

5+/L контакт сигнализации 2
4+/L контакт сигнализации 1
3+/L 24В пост. ток 3. Ступень
2+/L 24В пост. ток 2. Ступень
1+/L 24В пост. ток 1. Ступень
-/N 0В

Контролируемый модуль внизу:

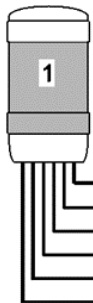

5+/L контакт сигнализации 2
4+/L контакт сигнализации 1
3+/L NC (not connected)
2+/L NC (not connected)
1+/L 24В пост. ток
-/N 0В

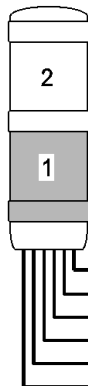

5+/L контакт сигнализации 2
4+/L контакт сигнализации 1
3+/L NC (not connected)
2+/L 24В пост. ток 2. Ступень
1+/L 24В пост. ток 1. Ступень
-/N 0В

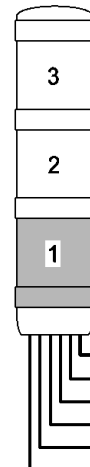

5+/L контакт сигнализации 2
4+/L контакт сигнализации 1
3+/L 24В пост. ток 3. Ступень
2+/L 24В пост. ток 2. Ступень
1+/L 24В пост. ток 1. Ступень
-/N 0В

*
Контролируемый модуль наверху и внизу: (макс. 2)

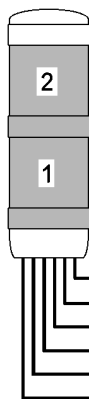

5+/L контакт сигнализации 2 Модуль 1
4+/L контакт сигнализации 1, общий контакт сигнализации 1
3+/L контакт сигнализации 2 Модуль 2
2+/L 24В пост. ток, 2. Ступень
1+/L 24В пост. ток, 1. Ступень
-/N 0В

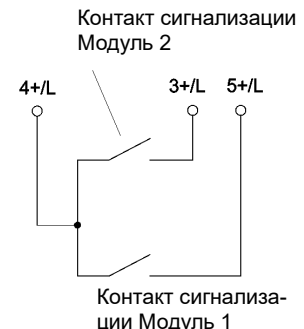

5.4 Звуковой оповещатель BR 50-SM

 Внезапное срабатывание звукового сигнала может привести к реакциям испуга.

Данные см. в разделе BR 50-SM.











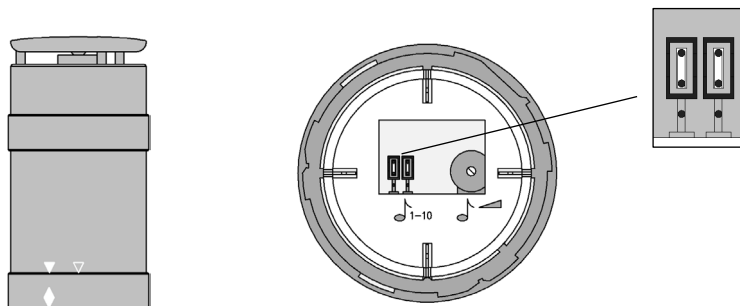
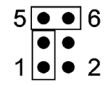

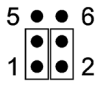
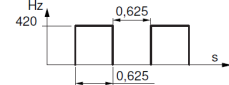
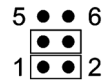
Таблица звуков

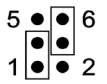
2			109		
16			110		
29			131		
35			146		
56*			167		

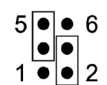
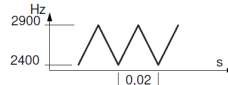
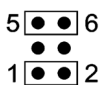
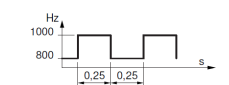
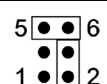
* Заводская установка

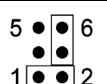
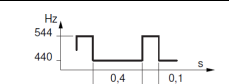
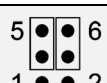
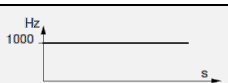
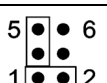
5.5 Звуковой оповещатель BR 50-SM HO



Внезапное срабатывание звука может привести к реакции испуга.

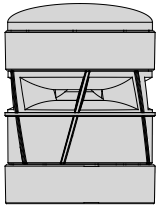

Звуковой модуль BR 50-SM HO может использоваться в качестве акустического модуля вместе с сигнальной башней Intense BR 50. Модуль позволяет выбрать один из 31 различных звуков и отрегулировать громкость. Модуль BR 50-SM HO всегда должен устанавливаться в верхней позиции.

Данные см. в разделе [BR 50-SM HO](#).

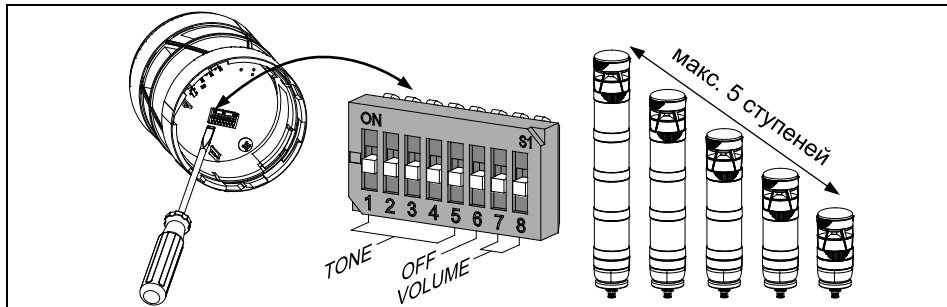

S1 (DIP1)		Громкость
7	8	дБ
		макс. *
ON		-7
	ON	-13
ON	ON	-20

* Заводские настройки

Переключатель S1 (DIP1) (Настройка основного тона)						Номер тона. (дБ)
1	2	3	4	5	6	
					OFF	162*
ON					OFF	2
	ON				OFF	9
ON	ON				OFF	15
		ON			OFF	18
ON		ON			OFF	22
	ON	ON			OFF	24
ON	ON	ON			OFF	26
			ON		OFF	27
ON			ON		OFF	29
	ON		ON		OFF	36
ON	ON		ON		OFF	54
		ON	ON		OFF	56
ON		ON	ON		OFF	60
	ON	ON	ON		OFF	63
ON	ON	ON	ON		OFF	71
				ON	OFF	82
ON				ON	OFF	83
	ON			ON	OFF	100
ON	ON			ON	OFF	102
		ON		ON	OFF	103
ON		ON		ON	OFF	104
	ON	ON		ON	OFF	112
ON	ON	ON		ON	OFF	123
			ON	ON	OFF	130
ON			ON	ON	OFF	131
	ON		ON	ON	OFF	146
ON	ON		ON	ON	OFF	160
		ON	ON	ON	OFF	161
ON		ON	ON	ON	OFF	163
	ON	ON	ON	ON	OFF	164
ON	ON	ON	ON	ON	OFF	1

5.6 Модуль AS-i

Всегда используйте модуль AS-i в крайнем нижнем положении:

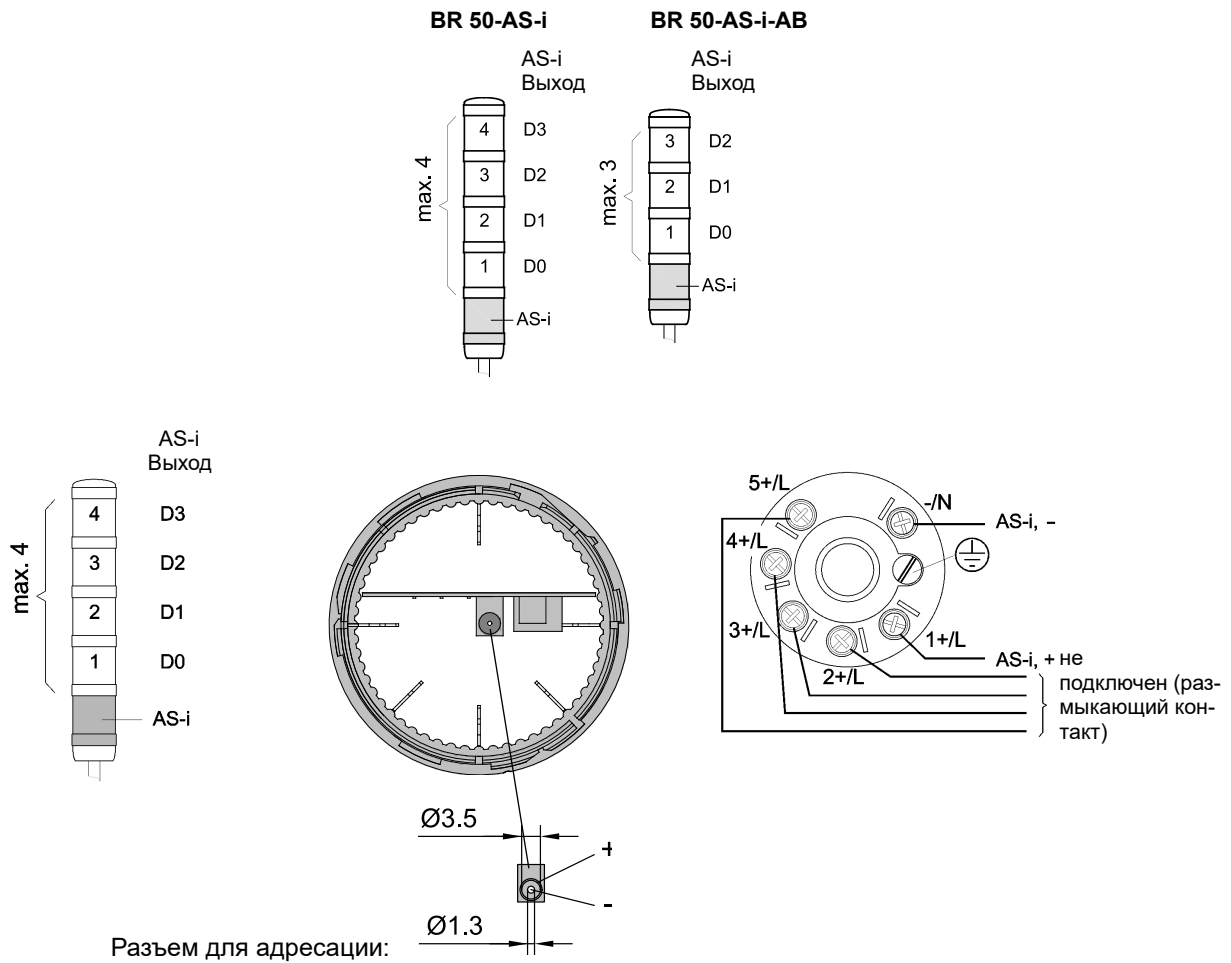

Технические данные:

	BR 50-AS-i	BR 50-AS-i-AB
Номинальное напряжение	26,5 В - 31,6 В	
макс. потребление номинального тока	285 мА	
Максимальное количество ступеней	4	3
Тип ступеней	Светодиодные модули, модуль сирены BR 50-SM	
Выходной ток общий Σ :	275 мА	
Спецификация AS-i	AS-i 3,0 / EN 50295	
Профиль AS-i	S-8.F.E	S-8.A.E
Конфигурация вводов/выводов / configuration [HEX]	8	
Идентиф. код [HEX]	F.E	A.E
макс количество ведомых устройств на главный	31	62
Адрес доставки	0	

6. Варианты монтажа

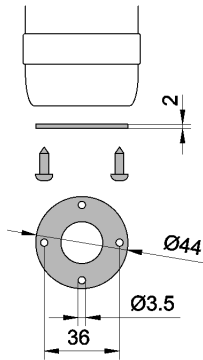
Комплект для прямого монтажа
BR 50-BG

Номер по каталогу: 28250210000

Труба с углом BR 50-T##

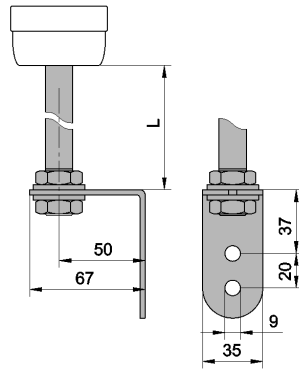

L [мм]
BR 50-T100 62,5
Номер по каталогу: 28250160010
BR 50-T250 212,5
Номер по каталогу: 28250160020
BR 50-T400 362,5
Номер по каталогу: 28250160040

Монтаж на штативе BR 50-S###

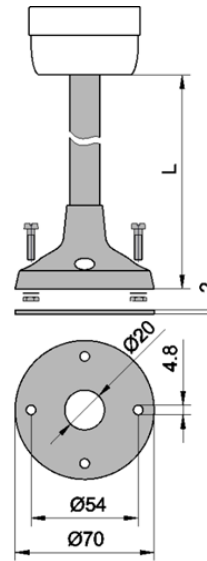

L [мм]
BR 50-S100 97,5
BR 50-S250 237,5
BR 50-S400 387,5

Номер по каталогу:
28250150010
Номер по каталогу:
28250150020
Номер по каталогу:
28250150040

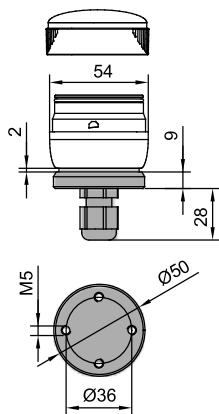
Прямой монтаж с разгрузкой от натяжения
BR 50-BC-SR

Номер по каталогу: 28250280000

Поверхностное
уплотнение входит
в комплект по-

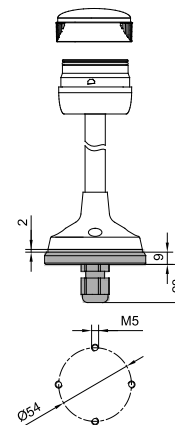
Крепление на штатив с разгрузкой от натяжения
BR 50-BC-Sxxx-SR

Номер по каталогу: 28250290000

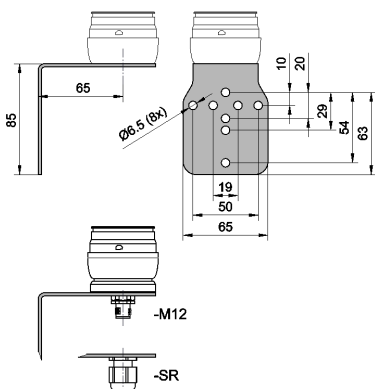
Угол для прямого монтажа BR 50-W
(нерж. сталь)

Номер по каталогу: 28250180000

Размеры в мм.

Во время установки необходимо использовать подходящий крепежный материал.

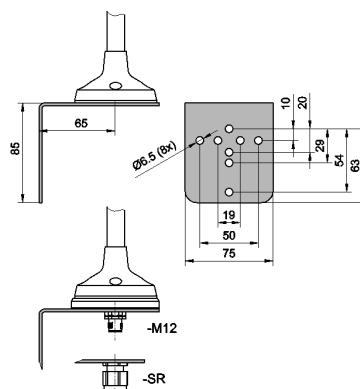
Угол для установки на штатив
BR 50-W (нерж. сталь)

Номер по каталогу: 28250190000

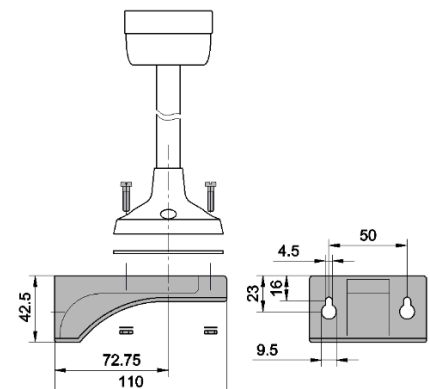
Угол для установки на штатив
BR 50-W (пластик)

Номер по каталогу: 28250200000

7. Технические данные

7.1 Общие сведения

Количество модулей (всего)	макс. 5	
Рабочая температура	-25 °C +50 °C	
Температура хранения	-40 °C +70 °C	
Степень защиты	IP 54 (EN 60529) Возможность расширения до IP 65 (Исключение: См. раздел 5.4 Звуковой оповещатель BR 50-SM)	
Материал	Модуль освещения: Базовый оконечный модуль, настенный угол для штатива (BR 50-S) Угол (прямой, крепление на штатив) Труба с углом (BR 50-T##):	Поликарбонат (PC) Acrylnitril-Butadien-Styrol (ABS) Нержавеющая сталь (VA)

7.2 Электрические данные

	Цвет светодиода	Рекомендуемый цвет модуля ...	Номинальное напряжение	Диапазон функционирования	Номинальный потребляемый ток макс.		Номер по каталогу
					перем. ток	пост. ток	
Светодиодная вставка ВА 15d <u>Постоянный свет</u>	белый	WH, BU, AM	24 В перем. ток / пост. ток	10 – 30 В перем. ток / пост. ток	114 мА	85 мА	28213000102
	желтый	YE			171 мА	85 мА	28213000099
	красный	RD			121 мА	85 мА	28213000100
	зеленый	GN			113 мА	85 мА	28213000101
	белый	WH, BU, AM	115 В перем. ток	+/- 10 %	22 мА	--	28213000118
	желтый	YE (желтый)			22 мА	--	28213000115
	красный	RD			26 мА	--	28213000116
	зеленый	GN			24 мА	--	28213000117
	белый	WH, BU, AM	230 В перем. ток	220 – 24 В перем. ток	22 мА	--	28213000106
	желтый	YE			19 мА	--	28213000103
	красный	RD			21 мА	--	28213000104
	зеленый	GN			22 мА	--	28213000105
Светодиодная вставка ВА 15d <u>Мигающий свет (1 Гц)</u>	белый	WH, BU, AM	24 В перем. ток / пост. ток	10 – 30 В перем. ток / пост. ток	57 мА	58 мА	28213000110
	желтый	YE			86 мА	51 мА	28213000107
	красный	RD			61 мА	37 мА	28213000108
	зеленый	GN			57 мА	53 мА	28213000109
	белый	WH, BU, AM	115 В перем. ток	+/- 10 %	22 мА	--	28213000122
	желтый	YE			22 мА	--	28213000119
	красный	RD			26 мА	--	28213000120
	зеленый	GN			24 мА	--	28213000121
	белый	WH, BU, AM	230 В перем. ток	220 – 24 В перем. ток	11 мА	--	28213000114
	желтый	YE			10 мА	--	28213000111
	красный	RD			11 мА	--	28213000112
	зеленый	GN			11 мА	--	28213000113

	Номинальное напряжение	Диапазон функционирования	Номинальное потребление тока		Энергия вспышки	Энергия вспышки
			перем. ток	пост. ток		
Вспышка BR 50-FL (Ксенон)	24 В перем. ток / пост.ток	10 – 27 В перем. ток 10 – 35 В пост. ток	100 мА		1 Дж	Прибл. 1 Гц
	115 В перем. ток	-10 – +15 %	20 мА	--	0,6 Дж	
	230 В перем. ток	-10 – +15 %	10,5 мА	--	0,6 Дж	

	Номинальное напряжение	Диапазон функционирования	перем.ток	пост. ток	Макс. уровень звука	Звуковые тоны
	115 В перем. ток	-10 – +10 %	15 мА	--		
	230 В перем. ток	-10 – +10 %	15 мА	--		

	Номинальное напряжение	Диапазон функционирования	перем.ток	пост. ток	Макс. уровень звука	Звуковые тоны

Контролируемый модуль BR 50-M	Данные см. в разделе 5.3 Контролируемый светодиодный модуль - BR 50-LED-M.
-------------------------------	--





BR 50 AS-i	Данные см. в разделе 5.6 Модуль AS-i
------------	--

7.3 Размеры

Общая высота собранных модулей Общая высота с модулем сирены: + 21 мм							
Диаметр: Ø 54мм 							
Количество сигнальных модулей	Монтаж на штативе BR 50-S### 			Монтаж на трубе BR 50-Txxx 			Прямой монтаж 
	Длина трубы			Длина трубы			
	100	250	400	100	250	400	-
1	183	333	483	209	359	509	107
2	246	396	546	272	422	572	170
3	309	459	609	335	485	635	233
4	372	522	672	398	584	698	296
5	435	585	735	461	611	761	359

Размеры в мм

8. Дополнительные принадлежности

Обозначение	Номер артикула		
Инструмент Flexi	28250250000		Упрощает установку источника света
Уплотнение модуля для IP 65	28250220000		1x на модуль плюс 1x для базового модуля (BR 50-BC..)
Уплотнение модуля для IP 65	28250230000		для установки на штатив или трубу
Светодиодная вставка для модулей Flexi <u>Постоянный свет</u>	См. 7.2 Электрические данные		
Светодиодная вставка для модулей Flexi <u>Мигающий свет</u>			
BR 50-BG Комплект для прямого монтажа	28250210000	См. раздел 6. Варианты монтажа	
Труба с углом BR 50-T100	28250160010		
Труба с углом BR 50-T250	28250160020		
Труба с углом BR 50-T400	28250160040		
BR 50-S100 Труба, крепление на штативе	28250150010 28250150020 28250150040		
Угол BR 50-W Прямой монтаж (нерж.сталь)	28250180000		
Угол BR 50-W для установки на штатив (нерж.сталь)	28250190000		
Угол BR 50-W для установки на штатив (пластик)	28250200000		

9. Техническое обслуживание, сервис, поддержание в исправном состоянии

- При выполнении любых работ на устройстве соблюдать [Правила техники безопасности](#).

Устройство не требует специального обслуживания.

- Выполнять наружную очистку слабым мыльным раствором без использования растворителей.
- Не используйте инструменты с острыми краями для очистки, особенно нельзя поцарапать бленду.
- Не используйте для очистки высокое давление.
- Замена компонентов только на оригинальные запасные части.
- Выполнение ремонта принципиально поручать проводить только на заводе-изготовителе.

Модификации, изменения, неправильное и недопустимое использование, а также несоблюдение указаний, приведенных в данном руководстве по эксплуатации, исключают гарантийные обязательства.

10. Вывод из эксплуатации, демонтаж и утилизация

- При выполнении любых работ на устройстве соблюдать [Правила техники безопасности](#).

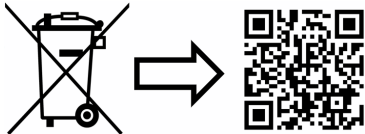

www.pfannenber.com/disposal



Pfannenberg
ELECTRO-TECHNOLOGY FOR INDUSTRY



Pfannenberg GmbH

Werner-Witt-Straße 1 · D- 21035 Hamburg

Тел.: +49/ (0)40/ 734 12-0

Факс: +49/ (0)40/ 734 12- 101

service@pfannenber.com

<http://www.pfannenber.com>