

**DE** MONTAGEANLEITUNG  
**EN** MOUNTING INSTRUCTIONS  
**FR** INSTRUCTIONS DE MONTAGE  
**IT** ISTRUZIONI DI MONTAGGIO  
**ES** INSTRUCCIONES DE MONTAJE  
**NL** MONTAGEHANDLEIDING  
**PL** INSTRUKCJA MONTAŻU



**TRILUX**  
SIMPLIFY YOUR LIGHT

## ARIMO FIT LED

ARIMO FIT M73 ...

ARIMO FIT M84-TS ...

ARIMO FIT M46 ...

ARIMO FIT M57-TS ...

ARIMO FIT M48 ...

ARIMO FIT M59-TS ...

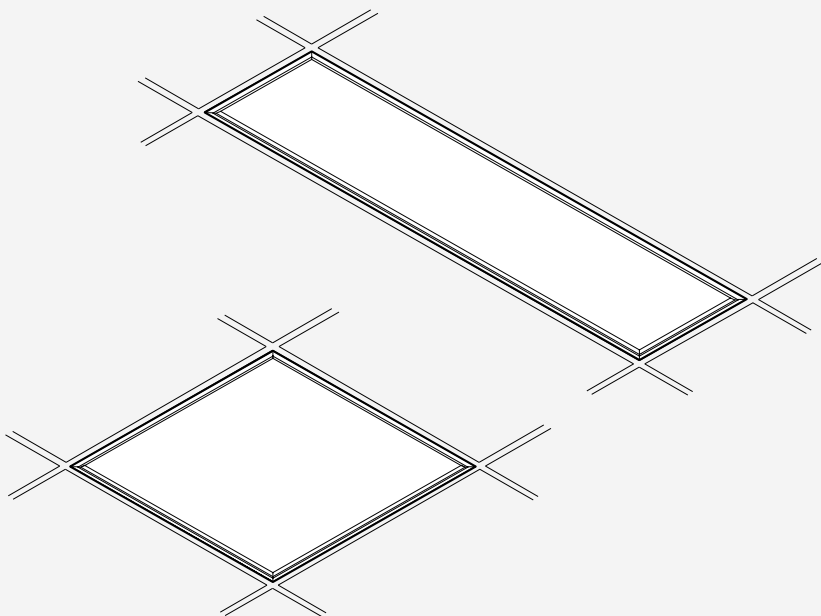

**Zu Ihrer Sicherheit**

Lesen Sie sorgfältig alle Hinweise und Montageschritte. Bewahren Sie die Anleitung für Wartungs- oder Demontearbeiten auf.

**Erläuterung der Warnstufen**

Beachten und befolgen Sie die Warnhinweise. Nichtbeachten der Warnhinweise kann zu Verletzungen oder Sachschäden führen!



**WARNUNG!** Kennzeichnet Gefahren, die schwere und/oder tödliche Verletzungen zur Folge haben können.



**VORSICHT!** Kennzeichnet Gefahren, die zu Verletzungen oder Gesundheitsgefährdungen führen können.



**WICHTIG.** Kennzeichnet Gefahren, die zu Sachschäden oder Funktionsstörungen führen können.



**TIPP.** Kennzeichnet Informationen, die einen Ratschlag oder nützlichen Hinweis enthalten.

**Erläuterung wichtiger Symboliken und Piktogramme**

Kennzeichnet fachkundiges Personal, das ausgebildet und befugt ist, den elektrischen Anschluss auszuführen.



Kennzeichnet fachkundiges Personal, das ausgebildet und befugt ist, die Montage auszuführen.

**Sicherheitshinweise**

**WARNUNG!** Gefahr eines elektrischen Schlages! Arbeiten Sie niemals bei anliegender Spannung an der Leuchte.



**WICHTIG.** Die Lichtquelle dieser Leuchte ist nicht ersetzbar! Wenn die Lichtquelle ihr Lebensdauerende erreicht hat, ersetzen Sie die gesamte Leuchte.



**WICHTIG.** Tragen Sie saubere Montagehandschuhe, um Verschmutzungen vorzubeugen.

**Wichtige Hinweise zu elektronischen Betriebsgeräten (EVG)**

Eine Neutralleiterunterbrechung im Drehstromkreis führt zu Überspannungsschäden in der Beleuchtungsanlage. Öffnen Sie die Neutralleiter-Trennklemme nur spannungsfrei und schließen Sie die Neutralleiter-Trennklemme vor Wiedereinschalten. Die maximal zulässige Umgebungstemperatur  $t_a$  der Leuchte darf nicht überschritten werden.

Eine Überschreitung reduziert die Lebensdauer, im Extremfall droht ein Frühausfall der Leuchte. Legen Sie die Anschlussleitungen für Steuereingänge dimmbarer EVG (1-10 V, DALI, etc.) 230 V netzspannungsfest (Basisisolierung) aus.

**Bestimmungsgemäße Verwendung**

Bestimmt für Innenräume mit einer Umgebungstemperatur von:  **$t_a$  25 °C**

Schutzklasse: **I**

Schutzklasse: **II**

Schutzart Anschlussraum: **IP20**

Schutzart raumseitig: **IP40**

Schutzart Anschlussraum: **IP20**

Schutzart raumseitig: **IP54**

**Entsorgung von Elektro- und Elektronik-Altgeräten**

Sammeln und entsorgen Sie Elektro- und Elektronik-Altgeräte am Ende ihrer Lebensdauer immer getrennt. Holen Sie sich im Zweifel Auskunft zur umweltgerechten Entsorgung bei der örtlichen Kommunalbehörde oder speziellen Entsorgungsfachbetrieben ein. Wichtige Informationen zur Energieeffizienz von TRILUX-Leuchten sowie zur Leuchtenwartung und -entsorgung finden Sie im Internet: [www.trilux.com/eg245](http://www.trilux.com/eg245)

**TouchDim-Steuerung \*\*\* ETDD**

TouchDim dient zur Steuerung einzelner Leuchten. Die Anzahl der Leuchten für eine TouchDim-Steuerung darf maximal 10 Leuchten betragen. Die Gesamtkabellänge (Taster bis zur letzten Leuchte) darf maximal 25 m betragen. TRILUX empfiehlt bei der Verwendung von mehreren Leuchten einer DALI-Steuerung oder bei TouchDim-Steuerung einen DALI-Repeater einzusetzen.

Ansonsten können durch Störeinflüsse im Gebäude Asynchronitäten begünstigt werden.

**TouchDim-Funktionsbeschreibung \*\*\* ETDD**

- Funktion: Operation
- Ein-/Ausschalten: Kurzer Tastendruck (<0.5 s)
- Dimmen: Mittellanger Tastendruck (>0.5 s) für ein Hoch-/Herunterdimmen
- Referenzwert speichern: Doppelklick (zweimaliges Drücken innerhalb von 0,4 s), wenn das Licht an ist.
- Taster loslassen und erneut drücken, um das Dimmen zu starten. Es erfolgt ein Herunterdimmen.
- Referenzwert löschen: Doppelklick, wenn das Licht aus ist.

**For your safety**

Read all instructions and mounting steps carefully. Keep the instructions for maintenance or disassembly work.

**Explanation of the warning levels**

Observe and follow the warnings.

Non-observance of the warnings may lead to injuries or material damage!



**WARNING!** Indicates dangers which can result in serious and/or fatal injuries.



**CAUTION!** Indicates dangers which can result in injuries or health hazards.



**NOTICE.** Indicates dangers which can result in material damage or malfunctions.



**TIP.** Indicates information containing advice or a useful note.

**Explanation of important symbols and pictograms**

Indicates professional personnel who are trained and authorised to carry out the electrical connection.



Indicates professional personnel who are trained and authorised to carry out the mounting.

**Safety notes**

**WARNING!** Risk of electric shock! Never work on the luminaire with voltage applied.



**NOTICE.** The light source of this luminaire cannot be replaced! When the light source has reached the end of its service life the whole luminaire shall be replaced.



**NOTICE.** Wear clean installation gloves to prevent soiling.

**Important information on electronic control gear units (ECG)**

A neutral conductor interruption in the three-phase circuit leads to overvoltage damage in the lighting system. Only open the neutral conductor isolating terminal in de-energised state, and close the neutral conductor isolating terminal before switching on again. Do not exceed the maximum permissible ambient temperature  $t_a$  of the luminaire.

Exceeding this limit reduces the service life and in extreme cases there is a risk of premature failure of the luminaire. Design connection cables for the control inputs of dimmable ECGs (1-10 V, DALI etc.) to be 230 V mains voltage-proof (basic insulation).

**Intended use**

Intended for indoor use with ambient temperature of: **ta 25 °C**

Safety class: **I**

Safety class: **II**

Protection rating of connection compartment: **IP20**

Protection rating on room side: **IP40**

Protection rating of connection compartment: **IP20**

Protection rating on room side: **IP54**

**Disposal of waste electrical and electronic equipment**

Always collect and dispose of old electrical and electronic equipment separately at the end of its service life.

In case of doubt, seek information about environmentally-compliant waste disposal from your local district authority or special waste disposal companies. For important information on the energy efficiency of TRILUX luminaires and on maintaining and disposing of luminaires, see the Internet at:

**[www.trilux.com/eg245](http://www.trilux.com/eg245)**

**TouchDim control ... ETDD**

TouchDim is used to control single luminaires.

The number of luminaires for a TouchDim control must not exceed 10. The total cable length (push-button up to the last luminaire) may not exceed 25 m. If several luminaires are used TRILUX recommends a DALI control, or with TouchDim control the use of a DALI repeater. Otherwise, asynchronisations are possible due to disturbances in the building.

**TouchDim function description ... ETDD**

- Function: operation
- Switch on/off: Short button press (<0.5 s)
- Dimming: Medium button press (>0.5 s) for up/down dimming
- Store the reference value: Double-click (press twice within 0.4 s) when the light is on.
- Delete reference value: Double-click when the light is off.

**Pour votre sécurité**

Lisez attentivement toutes les remarques et étapes de montage. Conservez ces instructions pour des travaux d'entretien ou de démontage.

**Explication des niveaux d'avertissement**

Respectez et suivez les avertissements. Le non-respect des avertissements peut entraîner des blessures ou des dommages matériels !



**AVERTISSEMENT !** Signale des risques pouvant résulter dans des blessures graves et/ou mortelles.



**ATTENTION !** Signale des risques pouvant entraîner des blessures ou des risques pour la santé.



**IMPORTANT.** Signale des risques pouvant entraîner des dommages matériels ou des dysfonctionnements.



**CONSEIL.** Signale des informations contenant un conseil ou une remarque utile.

**Explication des symboles et pictogrammes importants**

Signale un personnel qualifié, formé et autorisé à effectuer le raccordement électrique.



Signale un personnel qualifié, formé et autorisé à effectuer le montage.

**Recommandations de sécurité**

**AVERTISSEMENT !** Risque d'électrocution ! Ne travaillez jamais sur un luminaire sous tension.



**IMPORTANT.** La source de lumière de ce luminaire ne peut être remplacée ! Lorsque la source de lumière a atteint la fin de sa durée de vie, remplacez tout le luminaire.



**IMPORTANT.** Portez toujours des gants de montage propres afin d'éviter des encrassements.

**Remarques importantes concernant les ballasts électroniques (BE)**

Une interruption du conducteur neutre dans le circuit de courant triphasé entraîne des dommages de surtension dans l'installation d'éclairage. Ouvrez la borne de coupure du conducteur neutre lorsque l'installation est hors tension et fermez-la avant la remise sous tension. Ne dépassez jamais la température ambiante maximale admissible  $t_a$  du luminaire. Un dépassement réduit la durée de vie et peut, au pire, entraîner une défaillance prématurée du luminaire. Dimensionnez les câbles d'alimentation pour les entrées de commande de ballasts électroniques dimmables (1 à 10 V, DALI, etc.) afin qu'ils supportent une tension de secteur de 230 V (isolation de base).

**Utilisation conforme à l'usage prévu**

Conçu pour des espaces intérieurs à la température ambiante de :  $t_a$  25 °C

Classe électrique : I

Classe électrique : II

Indice de protection du compartiment de raccordement : **IP20**

Indice de protection par le dessous : **IP40**

Indice de protection du compartiment de raccordement : **IP20**

Indice de protection par le dessous : **IP54**

**Élimination de DEEE**

À la fin de leur durée de vie, collectez et éliminez toujours les DEEE de manière sélective. Si vous avez des doutes sur une élimination sans danger pour l'environnement, demandez auprès des autorités locales ou d'entreprises de valorisation. Vous trouverez des informations importantes relatives à l'efficacité énergétique des luminaires TRILUX ainsi que sur leur entretien et leur élimination sur notre site Web : [www.trilux.com/eg245](http://www.trilux.com/eg245)

**TouchDim control ... ETDD**

TouchDim is used to control single luminaires. The number of luminaires for a TouchDim control must not exceed 10. The total cable length (push-button up to the last luminaire) may not exceed 25 m. If several luminaires are used TRILUX recommends a DALI control, or with TouchDim control the use of a DALI repeater. Otherwise, asynchronisations are possible due to disturbances in the building.

**TouchDim function description ... ETDD**

- Function: operation
- Switch on/off: Short button press (<0.5 s)
- Dimming: Medium button press (>0.5 s) for up/down dimming
- Store the reference value: Double-click (press twice within 0.4 s) when the light is on.
- Delete reference value: Double-click when the light is off.



IT

## ARIMO FIT LED

**Per la propria sicurezza**

Leggere con attenzione tutti gli avvisi e le descrizioni delle varie fasi della procedura di montaggio. Conservare le istruzioni per poterle consultare al momento di eseguire lavori di manutenzione e smontaggio.

**Spiegazione dei livelli di avvertenza**

Osservare e attenersi alle avvertenze. Una mancata osservanza delle avvertenze può essere causa di lesioni o danni materiali!



**AVVERTENZA!** Mette in guardia dai pericoli che possono comportare lesioni gravi e/o mortali.



**ATTENZIONE!** Mette in guardia da pericoli che possono essere causa di lesioni o rischi per la salute.



**AVVISO.** Mette in guardia da pericoli che possono essere causa di danni materiali o disturbi di funzionamento.



**SUGGERIMENTO.** Indica informazioni comprendenti un consiglio o un avviso utile.

**Spiegazione di importanti simboli e pittogrammi**

Indica personale specializzato in possesso di formazione e autorizzazione necessarie per eseguire l'allacciamento elettrico.



Indica personale specializzato in possesso di formazione e autorizzazione necessarie per eseguire il montaggio.

**Avvertenze di sicurezza**

**AVVERTENZA!** Pericolo di scarica elettrica! Mai lavorare sull'apparecchio in presenza di tensione.



**AVVISO.** La sorgente luminosa di questo apparecchio non è sostituibile! Quando la sorgente luminosa è arrivata al termine della sua durata utile, sostituire l'intero apparecchio.



**AVVISO.** Durante le operazioni di montaggio usare guanti puliti per prevenire l'accumulo di sporco.

**Avvisi importanti sui reattori elettronici**

Un'interruzione del conduttore di neutro nel circuito trifase provoca danni da sovratensioni nell'impianto di illuminazione. Aprire il morsetto di sezionamento del conduttore di neutro solo senza tensione e chiuderlo prima del reinserimento. La massima temperatura ambiente ammissibile (ta) dell'apparecchio non deve essere oltrepassata. Questo ridurrebbe altrimenti la durata utile e, nel caso estremo, si rischierebbe un guasto precoce dell'apparecchio. Realizzare i cavi di allacciamento per ingressi di comando di reattori elettronici dimmerabili (1-10 V, DALI ecc.) in modo che presentino rigidità dielettrica con tensione di rete di 230 V (isolamento base).

**Impiego secondo destinazione**

Destinato all'impiego in interni con una temperatura ambiente **(ta) di 25 °C**

Classe di isolamento: **I**

Classe di isolamento: **II**

Grado di protezione vano di allacciamento: **IP20**

Grado di protezione verso il locale: **IP40**

Grado di protezione vano di allacciamento: **IP20**

Grado di protezione verso il locale: **IP54**

## ARIMO FIT LED

IT

**Smaltimento di rifiuti di apparecchiature elettriche ed elettroniche**

Alla fine del loro periodo di durata utile, raccogliere e smaltire i rifiuti di apparecchiature elettriche ed elettroniche sempre in modo differenziato.

Nel dubbio, si raccomanda di chiedere informazioni su uno smaltimento conforme alla normativa ambientale presso le autorità municipali del posto o aziende specializzate nello smaltimento di rifiuti.

Importanti informazioni sull'efficienza energetica di apparecchi TRILUX come anche sulla manutenzione e smaltimento degli stessi possono essere consultate in Internet:

[www.trilux.com/eg245](http://www.trilux.com/eg245)

**TouchDim control \*\*\* ETDD**

TouchDim is used to control single luminaires. The number of luminaires for a TouchDim control must not exceed 10. The total cable length (push-button up to the last luminaire) may not exceed 25 m. If several luminaires are used TRILUX recommends a DALI control, or with TouchDim control the use of a DALI repeater. Otherwise, asynchronisations are possible due to disturbances in the building.

**TouchDim function description \*\*\* ETDD**

- Function: operation
- Switch on/off: Short button press (<0.5 s)
- Dimming: Medium button press (>0.5 s) for up/down dimming
- Store the reference value: Double-click (press twice within 0.4 s) when the light is on.
- Delete reference value: Double-click when the light is off.



ES

## ARIMO FIT LED

### Para su seguridad

Por favor, lea detenidamente todas las indicaciones y los pasos de montaje. Guarde las instrucciones para los trabajos de mantenimiento y desmontaje.

### Explicación de los niveles de alerta

Por favor, tenga en cuenta y siga las indicaciones de peligro. ¡El incumplimiento de las indicaciones de peligro puede provocar lesiones o daños materiales!



**¡ADVERTENCIA!** Indica peligros que pueden provocar lesiones graves y/o mortales.



**¡ATENCIÓN!** Indica peligros que pueden provocar lesiones y riesgos de salud.



**¡IMPORTANTE!** Indica peligros que pueden provocar daños materiales o fallos de funcionamiento.



**CONSEJO.** Indica información con un consejo o una pista útil.

### Explicación de los símbolos y pictogramas importantes



Indica personal profesional formado y autorizado para la realización de la conexión eléctrica.



Indica personal profesional formado y autorizado para la realización del montaje.

### Avisos de seguridad



**¡ADVERTENCIA!** ¡Riesgo de descarga eléctrica! Nunca realice trabajos en la luminaria si esta tiene tensión.



**¡IMPORTANTE!** ¡La fuente de luz de esta luminaria no puede sustituirse! Al final de la vida útil de la fuente de luz, usted debe sustituir toda la luminaria.



**¡IMPORTANTE!** Póngase guantes de montaje limpios para evitar ensuciamiento.

### Avisos importantes en lo referente a los balastos electrónicos (EVGs)

Una interrupción del conductor neutro en el circuito de corriente trifásica provoca daños por sobretensión en la instalación de iluminación. Solamente abra el borne desconectador del conductor neutro cuando este esté desconectado de la tensión y cierre el borne desconectador del conductor neutro antes de la reconexión. No debe sobrepasarse la temperatura ambiente máxima admitida de la luminaria. Al sobrepasarla, la vida útil se reduce y, en un caso extremo, puede provocarse un fallo prematuro de la luminaria. Los cables de conexión para las entradas de control de los balastos electrónicos (EVGs) regulables (1-10 V, DALI, etc.) 230 V deben ser resistentes a la tensión de red (aislamiento básico).

### Uso previsto

Destinado para espacios interiores con una temperatura ambiente: **ta de 25 °C**

Grado de protección: I

Grado de protección: II

Grado de protección del espacio de conexión: **IP20**

Grado de protección hacia el local: **IP40**

Grado de protección del espacio de conexión: **IP20**

Grado de protección hacia el local: **IP54**

### Eliminación de dispositivos eléctricos y electrónicos antiguos



Recoja y elimine los dispositivos eléctricos y electrónicos antiguos siempre por separado al final de su vida útil. En caso de duda, consulte las autoridades comunales o las empresas especializadas en eliminación de residuos para tener información sobre la eliminación respetuosa con el medio ambiente. En Internet puede encontrar información sobre la eficiencia energética de las luminarias de TRILUX, así como sobre el mantenimiento y la eliminación de las luminarias: [www.trilux.com/eg245](http://www.trilux.com/eg245)

## ARIMO FIT LED

ES



### TouchDim control \*\*\* ETDD

TouchDim is used to control single luminaires. The number of luminaires for a TouchDim control must not exceed 10. The total cable length (push-button up to the last luminaire) may not exceed 25 m. If several luminaires are used TRILUX recommends a DALI control, or with TouchDim control the use of a DALI repeater. Otherwise, asynchronisations are possible due to disturbances in the building.

### TouchDim function description \*\*\* ETDD

- Function: operation
- Switch on/off: Short button press (<0.5 s)
- Dimming: Medium button press (>0.5 s) for up/down dimming
- Store the reference value: Double-click (press twice within 0.4 s) when the light is on.
- Delete reference value: Double-click when the light is off.

**Voor uw veiligheid**

Lees alle aanwijzingen en montagestappen zorgvuldig. Bewaar de handleiding voor latere onderhouds- of demontagewerkzaamheden.

**Verklaring van de waarschuwniveaus**

Neem de waarschuwingen in acht en volg de instructies. Bij niet-naleving kan letsel of materiële schade het gevolg zijn!



**WAARSCHUWING!** Wijst op gevaren die zware en/of dodelijke letsels tot gevolg kunnen hebben.



**VOORZICHTIG!** Wijst op gevaren die kunnen leiden tot letsels of gezondheidsrisico's.



**BELANGRIJK!** Wijst op gevaren die kunnen leiden tot materiële schade of functionele storingen.



**TIP.** Wijst op informatie die een advies of een nuttige aanwijzing bevat.

**Verklaring van belangrijke symbolen en pictogrammen**

Verwijst naar vakkundig personeel dat opgeleid en bevoegd is om de elektrische aansluiting uit te voeren.



Verwijst naar vakkundig personeel dat opgeleid en bevoegd is om de montage uit te voeren.

**Veiligheidsinstructies**

**WAARSCHUWING!** Gevaar voor een elektrische schok! Werk nooit aan de armatuur terwijl deze onder spanning staat.



**BELANGRIJK!** De lichtbron van deze armatuur kan niet worden vervangen. Als de lichtbron het einde van haar levensduur bereikt heeft, dient de hele armatuur vervangen te worden.



**BELANGRIJK!** Draag schone montagehandschoenen, om verontreiniging te voorkomen.

**Belangrijke aanwijzingen met betrekking tot elektronische voorschakelapparaten (EVSA's)**

Een onderbreking van de nulleider in de draaistroomkring veroorzaakt schade door overspanning in de verlichtingsinstallatie. Open de nullem alleen als de kring spanningsvrij is en sluit de nullem alvorens de spanning weer in te schakelen. De maximaal toelaatbare omgevingstemperatuur (ta) van de armatuur mag niet overschreden worden. Overschrijding van de maximumtemperatuur kan de levensduur van de armatuur verkorten en in extreme gevallen zelfs leiden tot vroegtijdige uitval. De aansluitleidingen voor sturingangen van dimbare EVSA's (1-10 V, DALI enz.) moeten geschikt zijn voor een netspanning van 230 V (basisisolatie).

**Bedoeld gebruik**

Bedoeld voor binnengebruik bij een omgevingstemperatuur van **ta 25 °C**

Beschermcategorie: **I**

Beschermcategorie: **II**

Beschermklasse aansluitcompartiment: **IP20**

Beschermklasse aan de zijde van de ruimte: **IP40**

Beschermklasse aansluitcompartiment: **IP20**

Beschermklasse aan de zijde van de ruimte: **IP54**

**Afvoer van afgedankte elektrische en elektronische apparaten**

Afgedankte elektrische en elektronische apparaten moeten altijd gescheiden van het andere afval worden bewaard en afgevoerd. Vraag in geval van twijfel aan de plaatselijke bevoegde openbare dienst of een gespecialiseerd afvalverwerkingsbedrijf hoe u deze apparaten afdankt met respect voor het milieu. Belangrijke informatie betreffende de energie-efficiëntie van TRILUX-armaturen en het onderhoud en de afdanking van de armaturen vindt u op de website: [www.trilux.com/eg245](http://www.trilux.com/eg245)

**TouchDim control ... ETDD**

TouchDim is used to control single luminaires. The number of luminaires for a TouchDim control must not exceed 10. The total cable length (push-button up to the last luminaire) may not exceed 25 m. If several luminaires are used TRILUX recommends a DALI control, or with TouchDim control the use of a DALI repeater. Otherwise, asynchronisations are possible due to disturbances in the building.

**TouchDim function description ... ETDD**

- Function: operation
- Switch on/off: Short button press (<0.5 s)
- Dimming: Medium button press (>0.5 s) for up/down dimming
- Store the reference value: Double-click (press twice within 0.4 s) when the light is on.
- Delete reference value: Double-click when the light is off.



PL

ARIMO FIT LED

### Zasady bezpieczeństwa

Należy uważnie przeczytać wszystkie instrukcje i czynności montażowe. Zachować instrukcję na wypadek konserwacji lub demontażu.

### Wyjaśnienie poziomów ostrzeżenia

Przestrzegać wskazówek ostrzegawczych. Nieprzestrzeganie wskazówek ostrzegawczych może spowodować obrażenia ciała lub szkody rzeczowe!



**OSTRZEŻENIE!** Oznacza zagrożenia, które mogą prowadzić do poważnych i/lub śmiertelnych obrażeń ciała.



**UWAGA!** Oznacza zagrożenia, które mogą prowadzić do obrażeń ciała lub zagrożenia dla zdrowia.



**WSKAZÓWKA.** Oznacza zagrożenia, które mogą prowadzić do szkód materialnych lub nieprawidłowego działania.



**PORADA.** Oznacza informacje, które zawierają poradę lub przydatną wskazówkę.

### Wyjaśnienie ważnych symboli i piktogramów



Oznacza wykwalifikowany personel, który jest przeszkolony i upoważniony do wykonania przyłącza elektrycznego.



Określa kompetentny personel, który jest przeszkolony i upoważniony do przeprowadzenia montażu.

### Wskazówki bezpieczeństwa



**OSTRZEŻENIE!** Niebezpieczeństwo porażenia prądem elektrycznym! Nigdy nie pracować przy oprawie pod napięciem.



**WSKAZÓWKA.** Źródła światła tej oprawy nie można wymieniać! Po upływie okresu eksploatacji źródła światła należy wymienić całą oprawę.



**WSKAZÓWKA.** Aby zapobiec zabrudzeniom, należy nosić czyste rękawice montażowe.

### Ważne wskazówki dotyczące stateczników elektronicznych

Przerwanie przewodu zerowego w obwodzie trójfazowym prowadzi do uszkodzenia instalacji oświetleniowej na skutek przepięcia. Zacisk rozłączny przewodu zerowego należy rozwiązać tylko po odłączeniu od zasilania i zewrzeć go ponownie przed ponownym włączeniem. Nie przekraczać maksymalnej dopuszczalnej temperatury otoczenia ta oprawy. Przejrzanie skraca trwałość urządzenia, a w ekstremalnych przypadkach grozi przedwczesną awarią oprawy. Przewody podłączeniowe wejść sterujących ściemniających stateczników elektronicznych (1...10 V, DALI itp.) muszą mieć izolację dopuszczoną do pracy pod napięciem 230 V (izolacja podstawowa).

### Zastosowanie zgodnie z przeznaczeniem

Przeznaczona do eksploatacji w pomieszczeniach o temperaturze otoczenia **ta 25°C**

Klasa ochronności: I

Klasa ochronności: II

Stopień ochrony komory przyłączeniowej: **IP20**

Stopień ochrony od strony pomieszczenia: **IP40**

Stopień ochrony komory przyłączeniowej: **IP20**

Stopień ochrony od strony pomieszczenia: **IP54**

ARIMO FIT LED

PL



### Utylizacja zużytego sprzętu elektrycznego i elektronicznego



Po zakończeniu okresu eksploatacji zużyte urządzenia elektryczne i elektroniczne należy zawsze zbierać i utylizować oddzielnie. W przypadku wątpliwości należy uzyskać informacje na temat przyjaznego dla środowiska usuwania odpadów od władz lokalnych lub firm zajmujących się utylizacją odpadów specjalnych. Ważne informacje dotyczące wydajności energetycznej opraw TRILUX oraz ich konserwacji i utylizacji znaleźć można w internecie pod adresem: [www.trilux.com/eg245](http://www.trilux.com/eg245)

### TouchDim control ... ETDD

TouchDim is used to control single luminaires. The number of luminaires for a TouchDim control must not exceed 10. The total cable length (push-button up to the last luminaire) may not exceed 25 m. If several luminaires are used TRILUX recommends a DALI control, or with TouchDim control the use of a DALI repeater. Otherwise, asynchronisations are possible due to disturbances in the building.

### TouchDim function description ... ETDD

- Function: operation
- Switch on/off: Short button press (<0.5 s)
- Dimming: Medium button press (>0.5 s) for up/down dimming
- Store the reference value: Double-click (press twice within 0.4 s) when the light is on.
- Delete reference value: Double-click when the light is off.



# ARIMO FIT LED

Type	≈ kg
ARIMO FIT M73 ...	3,6
ARIMO FIT M84-TS ...	3,7

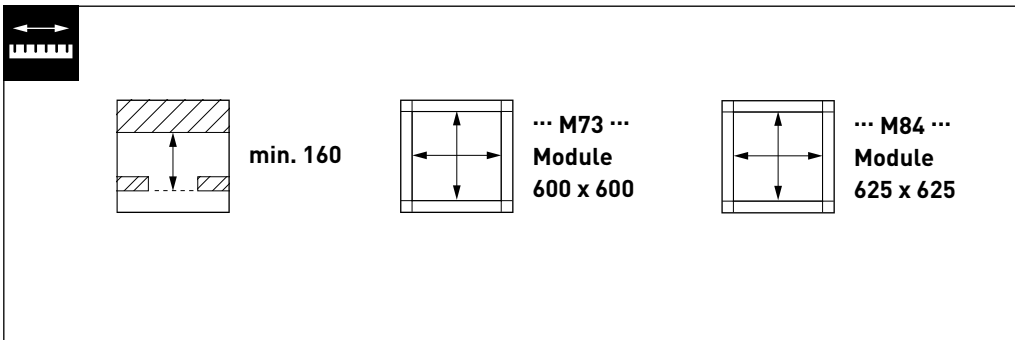
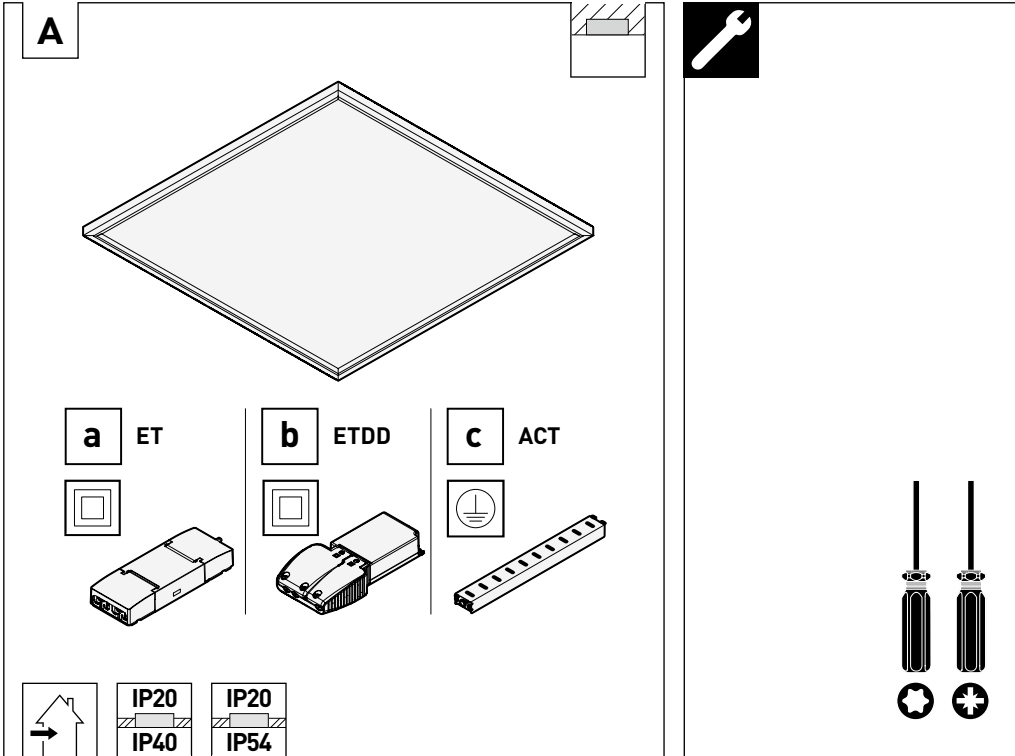

# ARIMO FIT LED

Type	
ARIMO FIT M73 ...	
ARIMO FIT M84-TS ...	

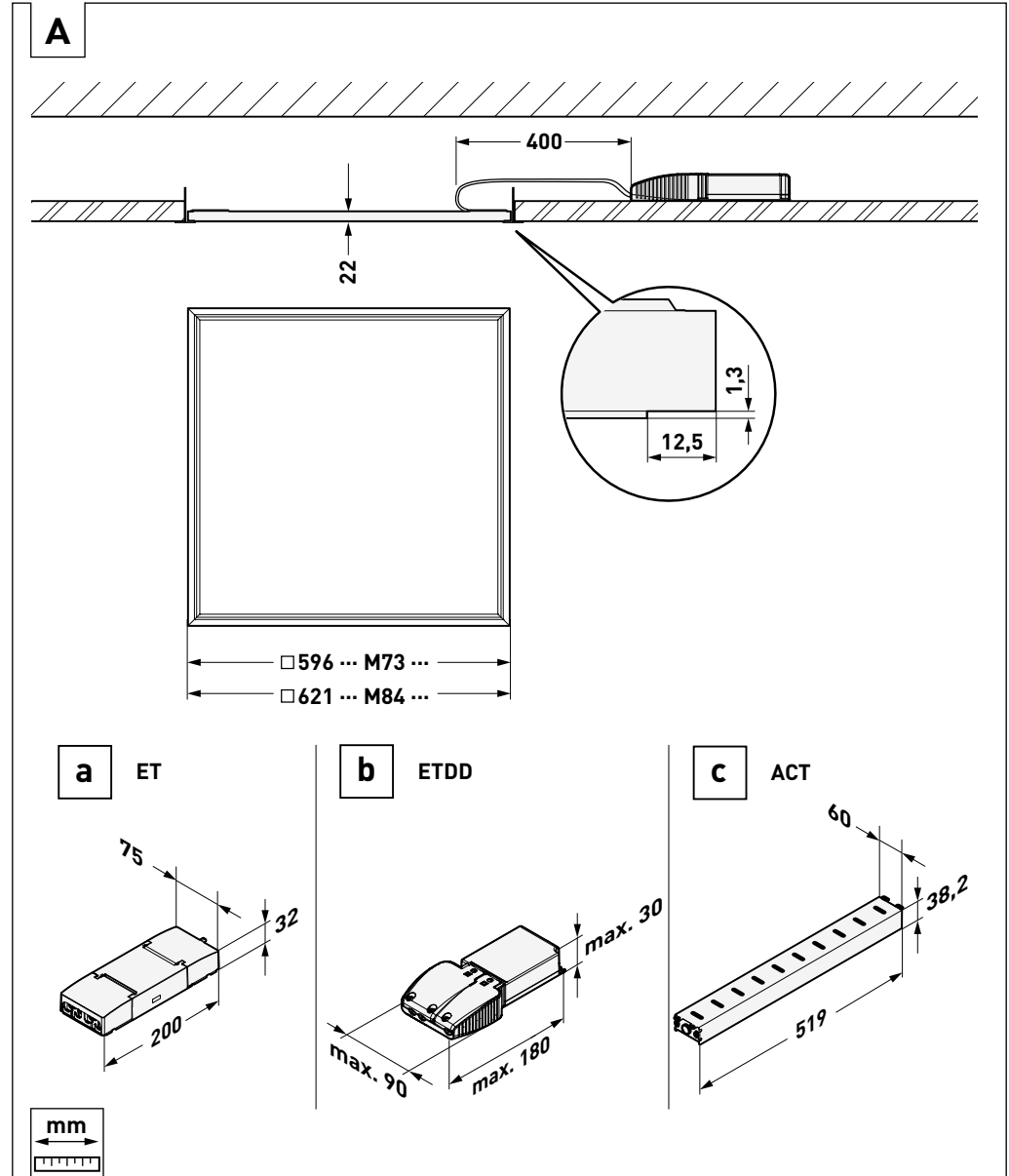



# ARIMO FIT LED

Type	≈ kg
ARIMO FIT M46 ...	3,6
ARIMO FIT M57-TS ...	3,9
ARIMO FIT M48 ...	4,5
ARIMO FIT M59-TS ...	5,3

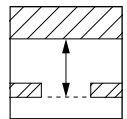
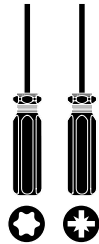
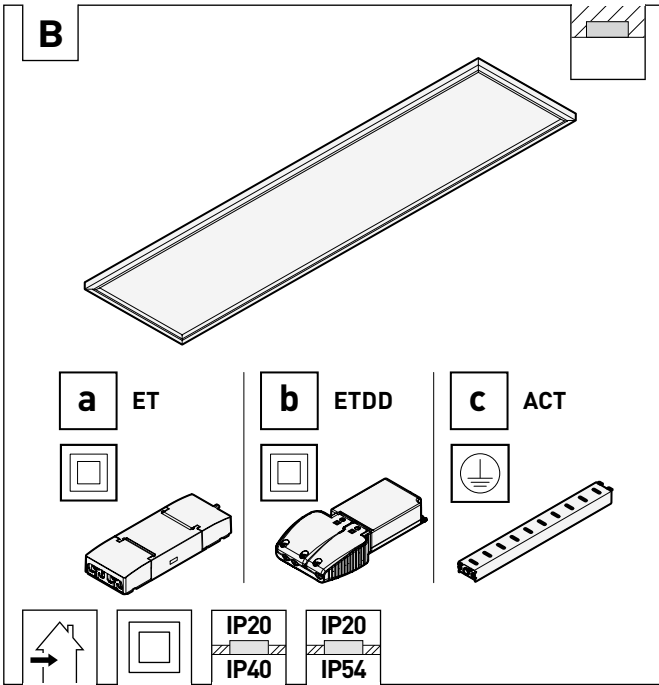

min. 160

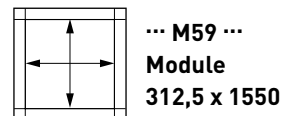
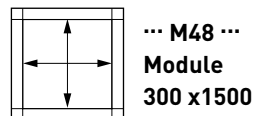
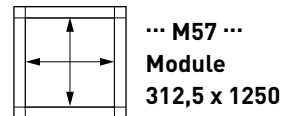
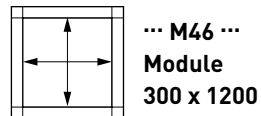

# ARIMO FIT LED



Type
ARIMO FIT M46 ...
ARIMO FIT M57-TS ...
ARIMO FIT M48 ...
ARIMO FIT M59-TS ...

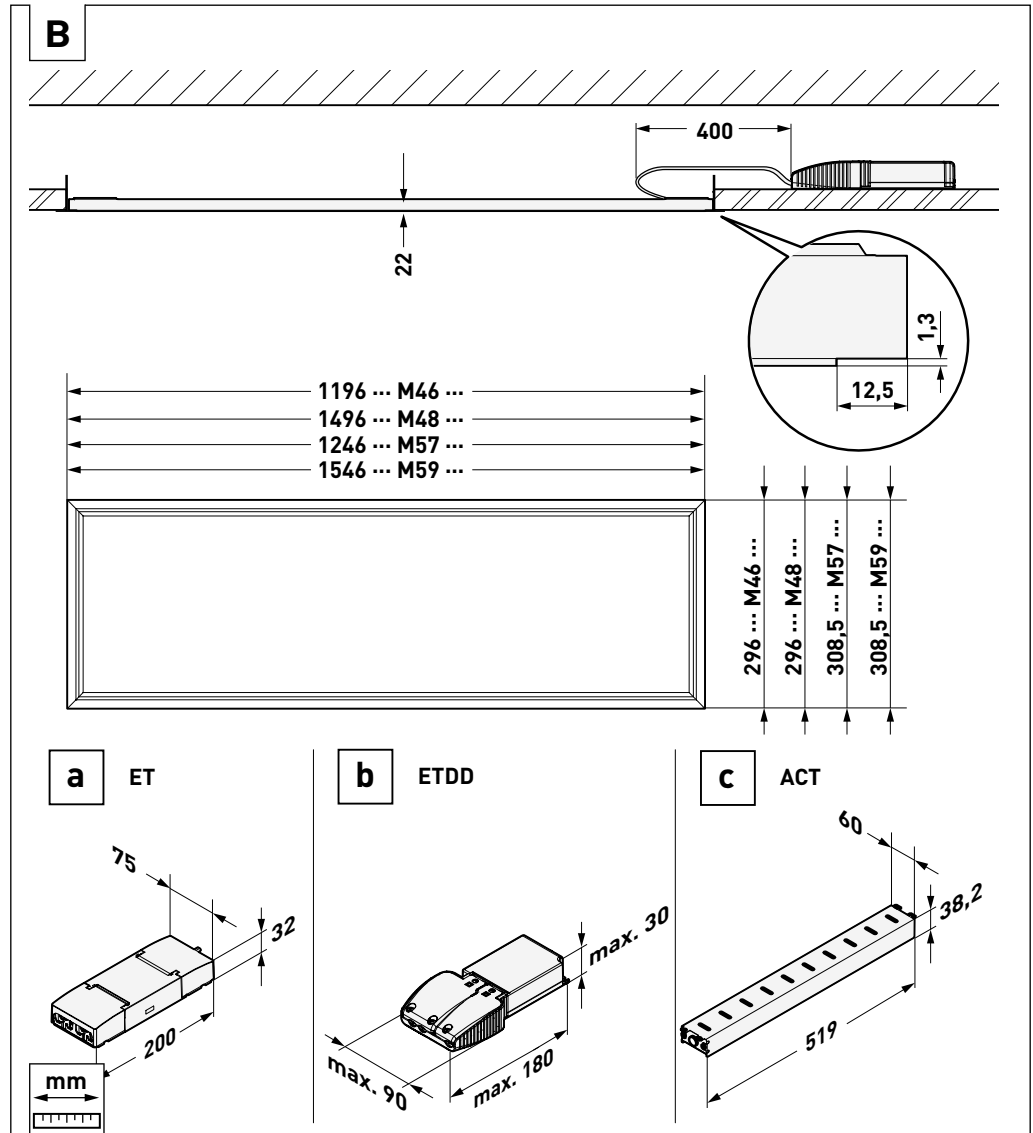



# ARIMO FIT LED

i

A

B

i

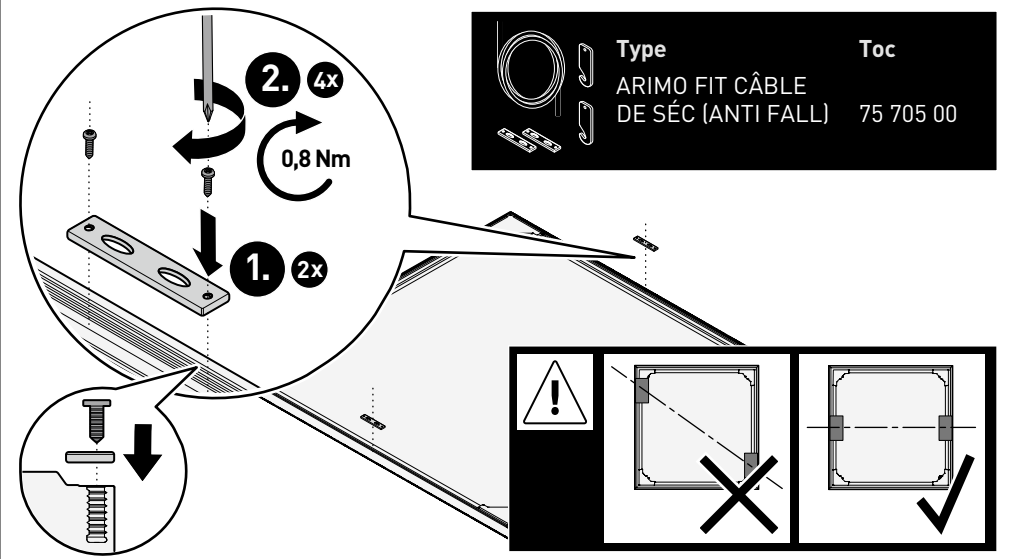

# ARIMO FIT LED

i

A

B

i

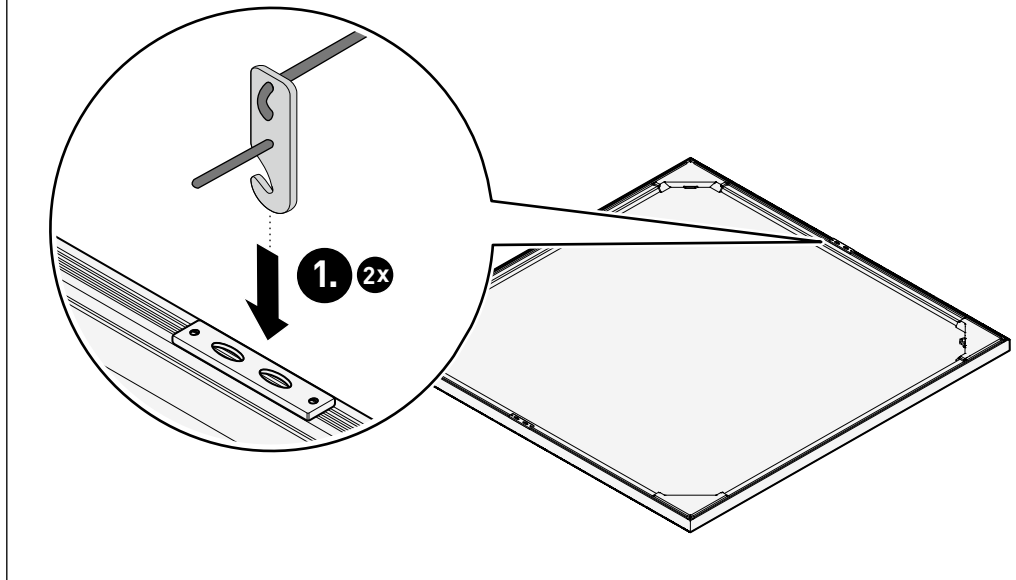

i

A

B

i

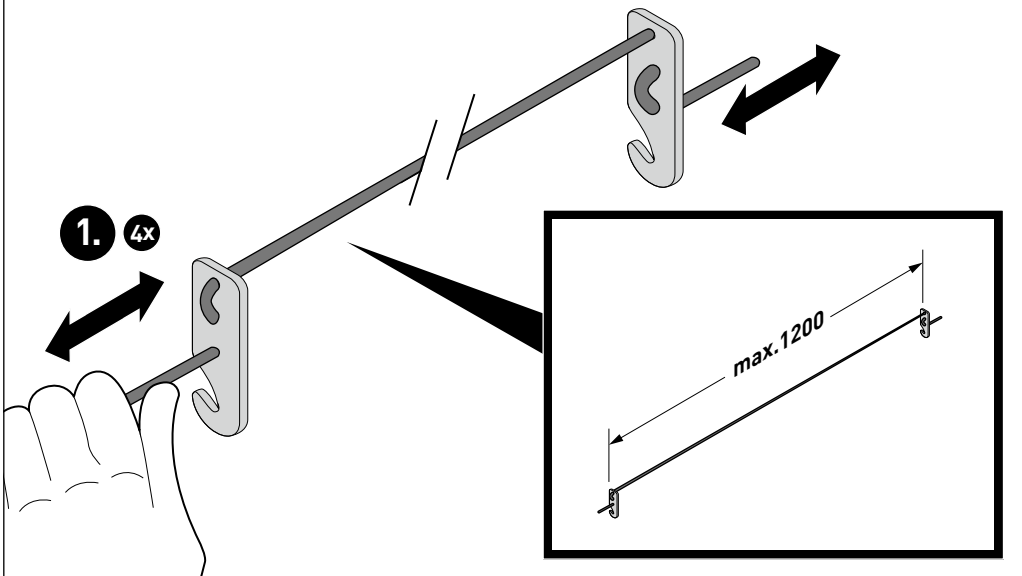

i

A

B

i

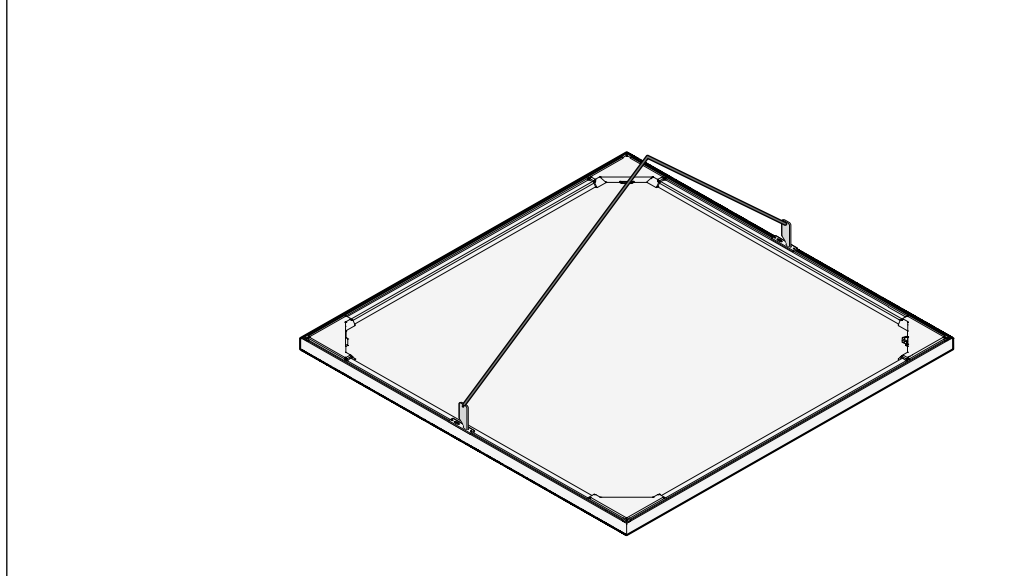



# ARIMO FIT LED

01

a

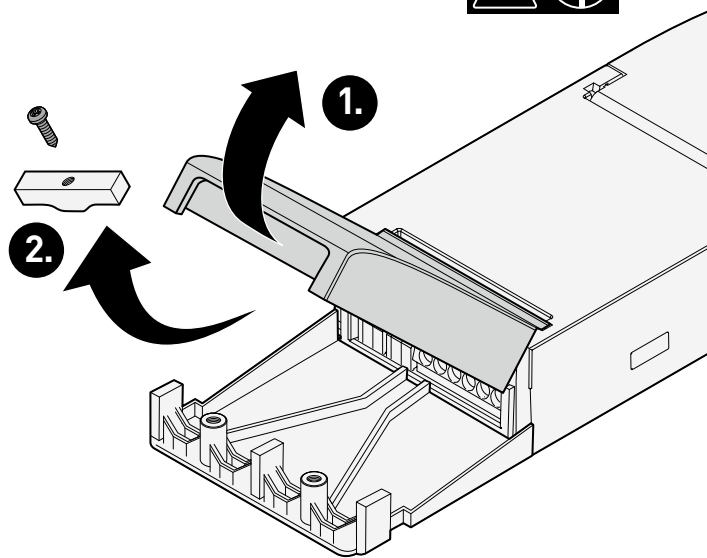
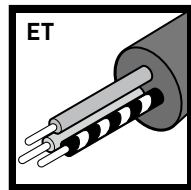

02

a

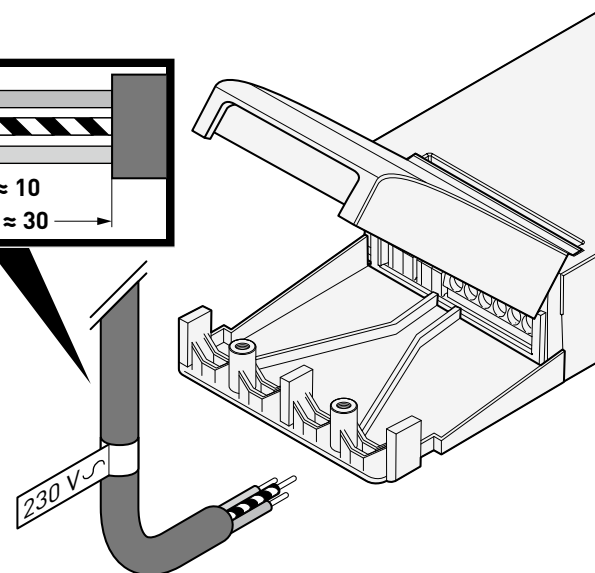
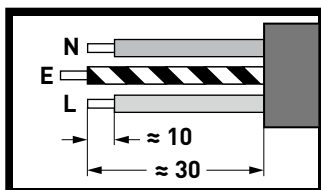
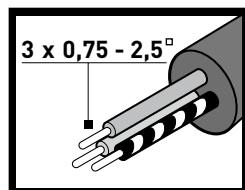

# ARIMO FIT LED



03

a

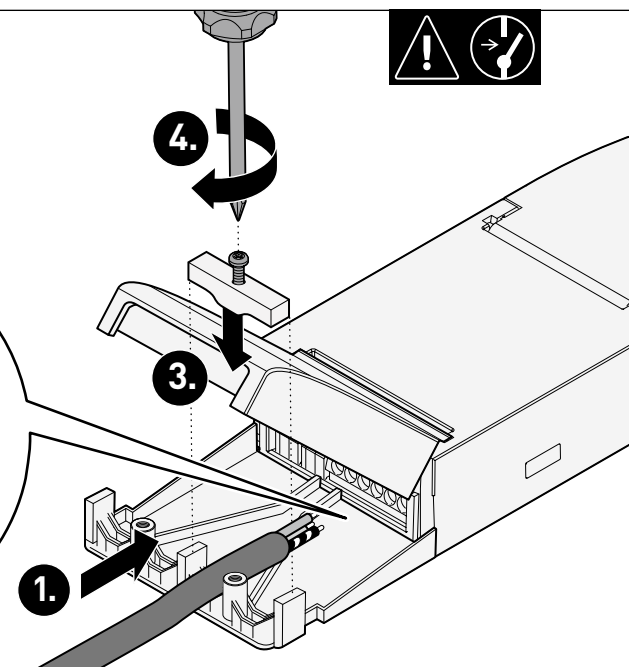
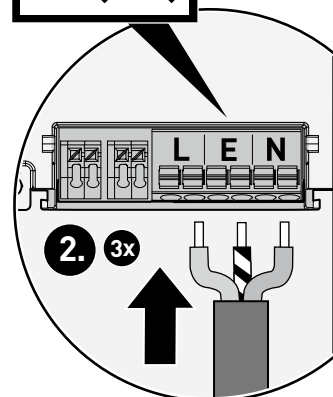
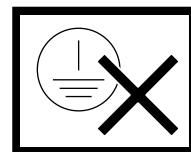

04

a

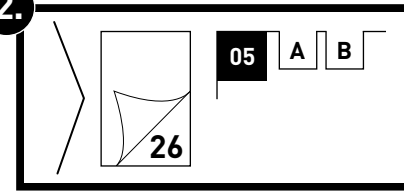
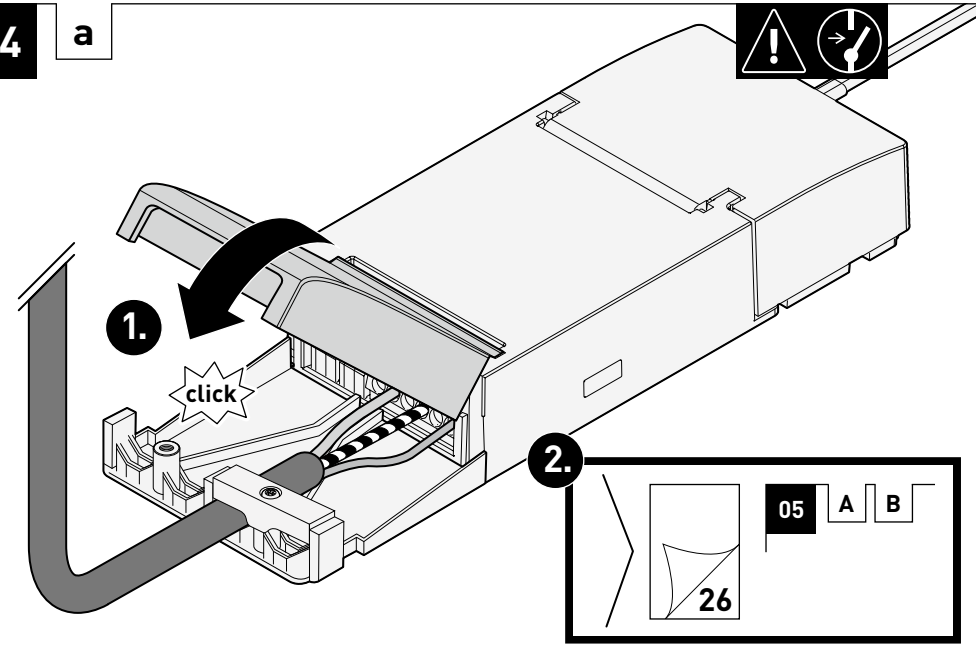



# ARIMO FIT LED

01

b

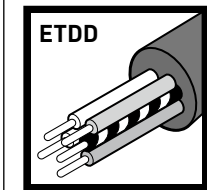

1. 2x

2.

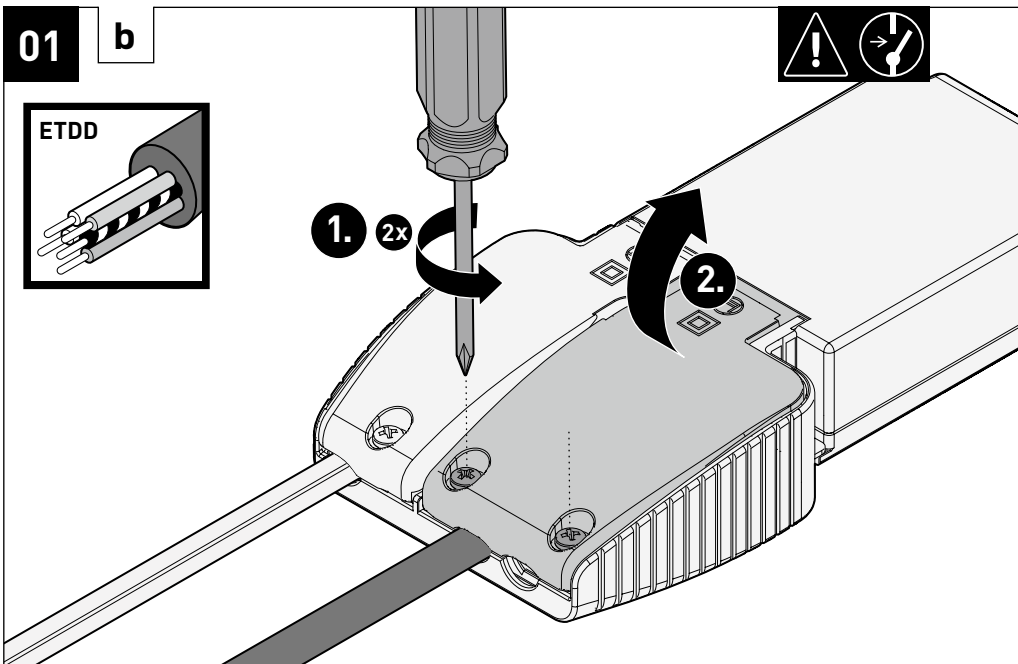

02

b

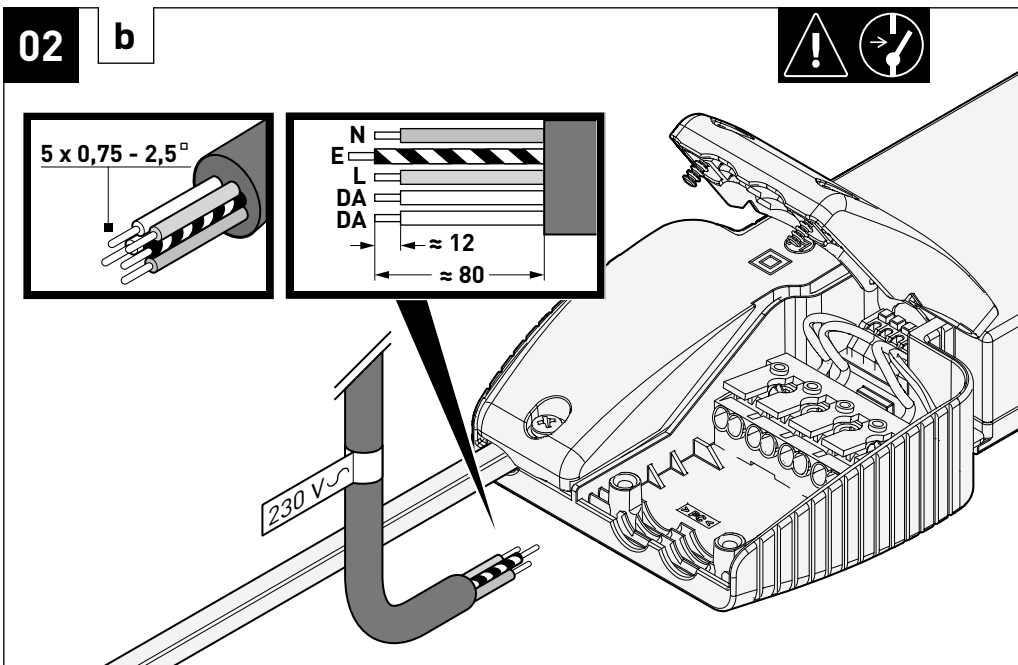
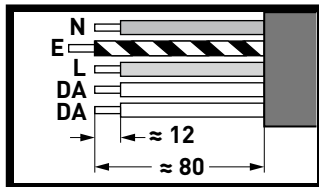
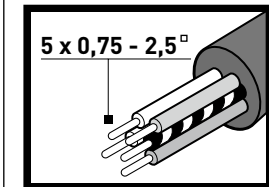

# ARIMO FIT LED



03

b

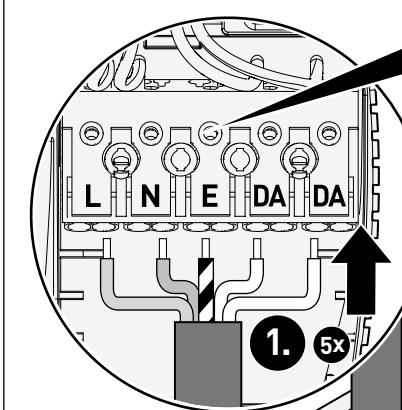

1. 5x

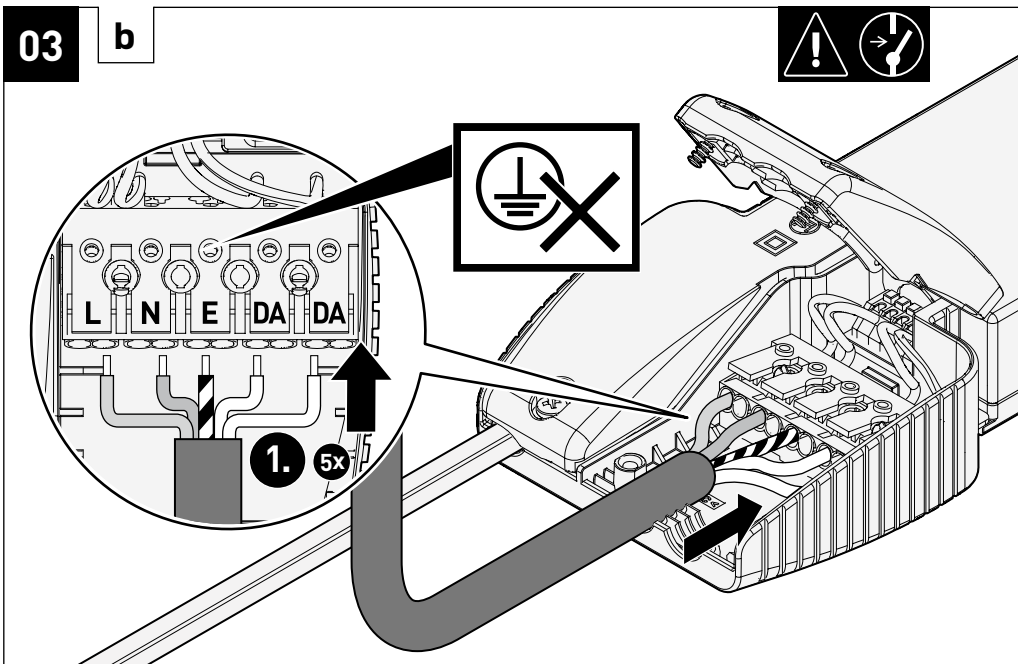

04

b



2. 2x

1.

3.

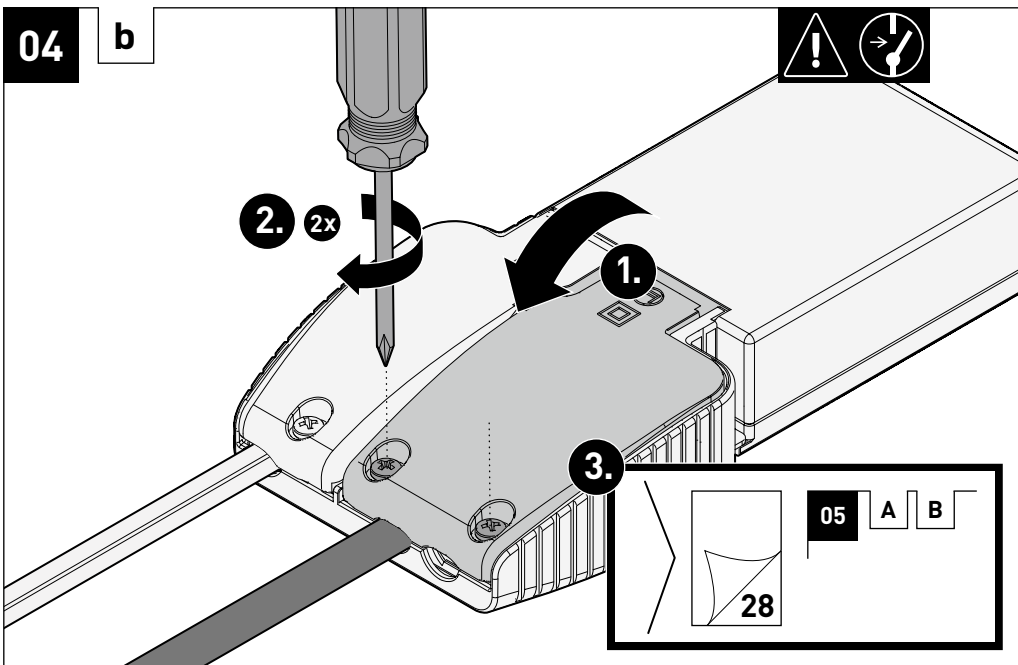



# ARIMO FIT LED

01

c

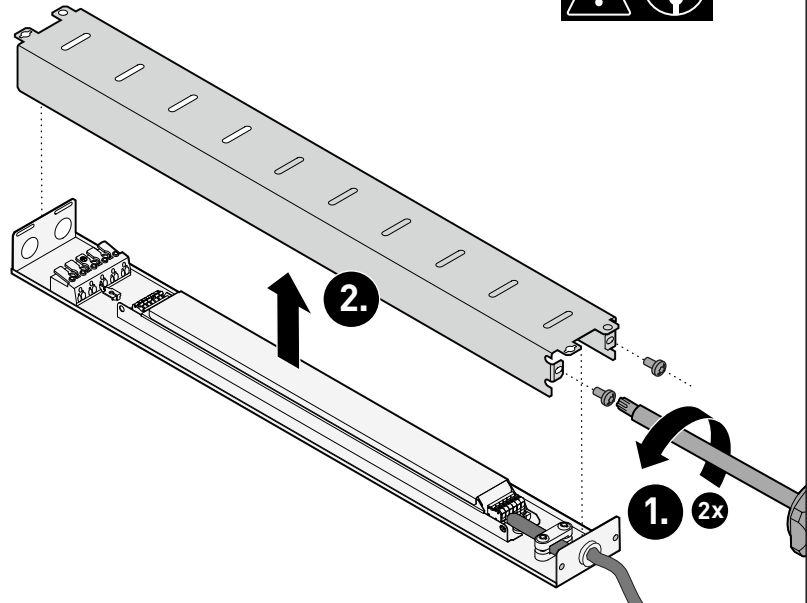
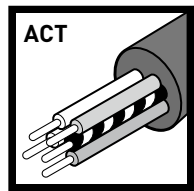

02

c

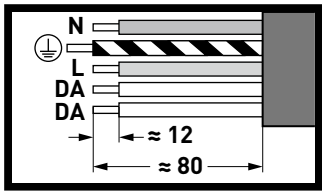
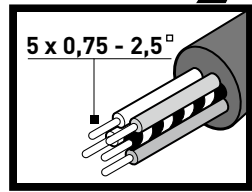
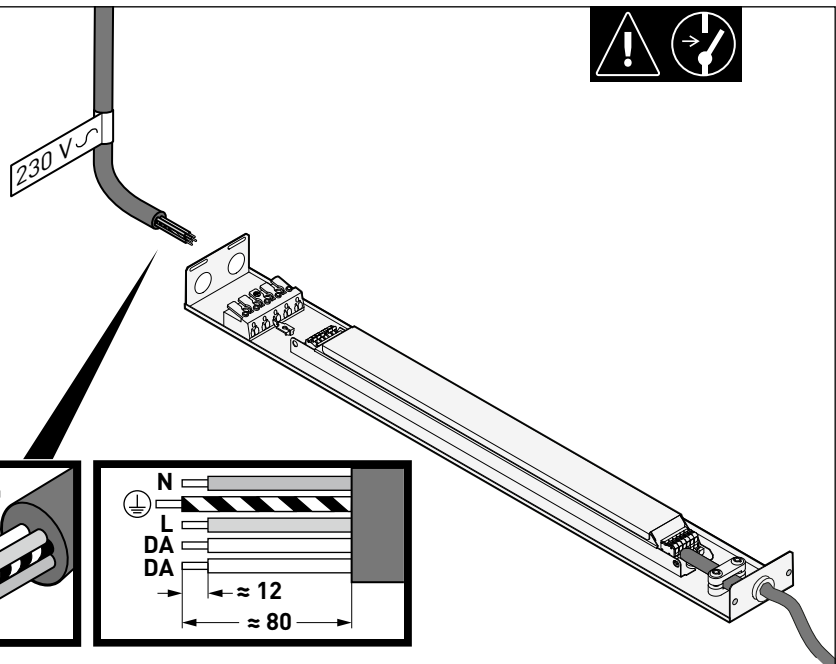

# ARIMO FIT LED



03

c

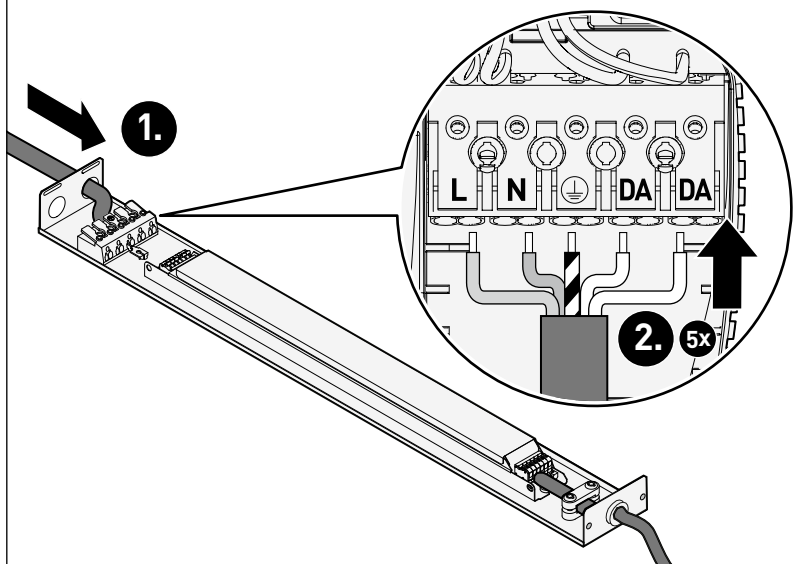

04

c

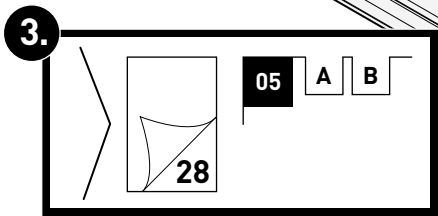
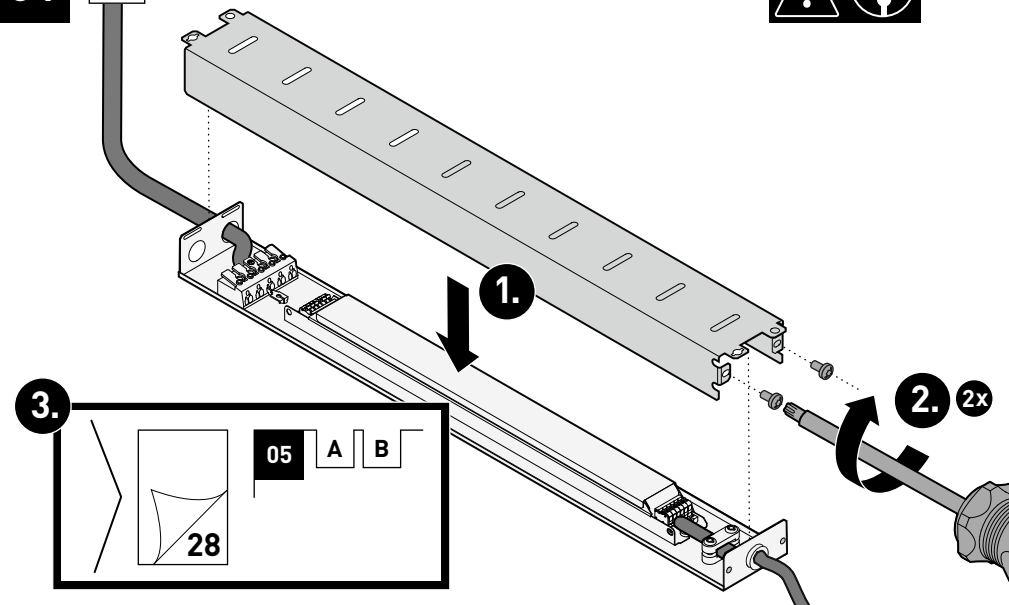



05

A

B



1.

 **NO HOT PLUGGING**

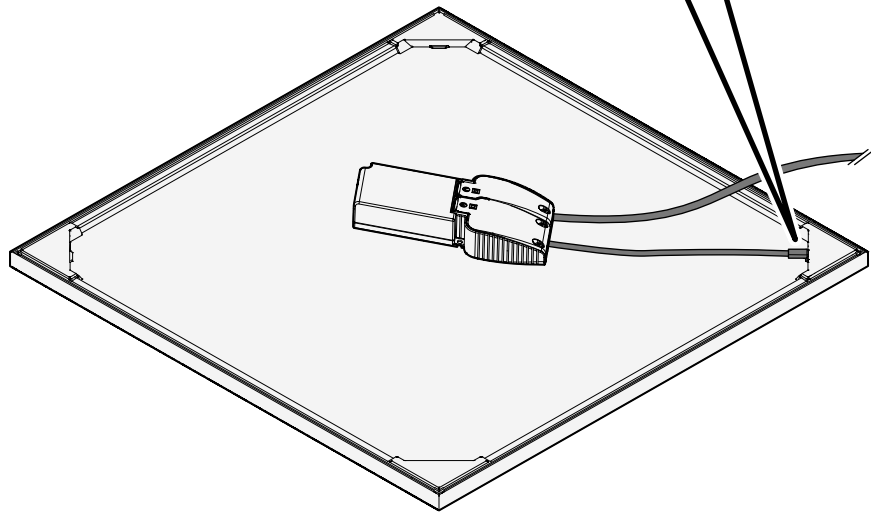
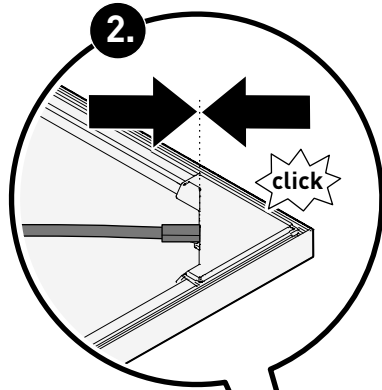



06

A

B

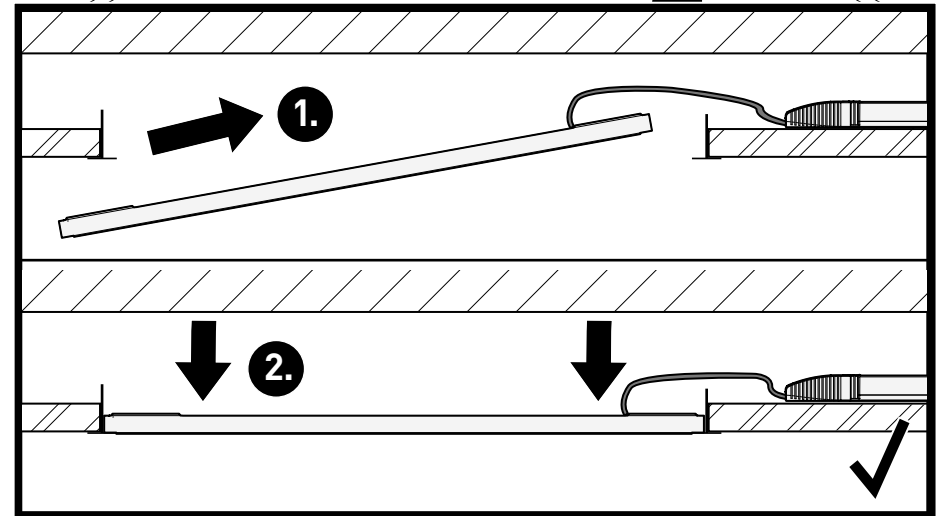
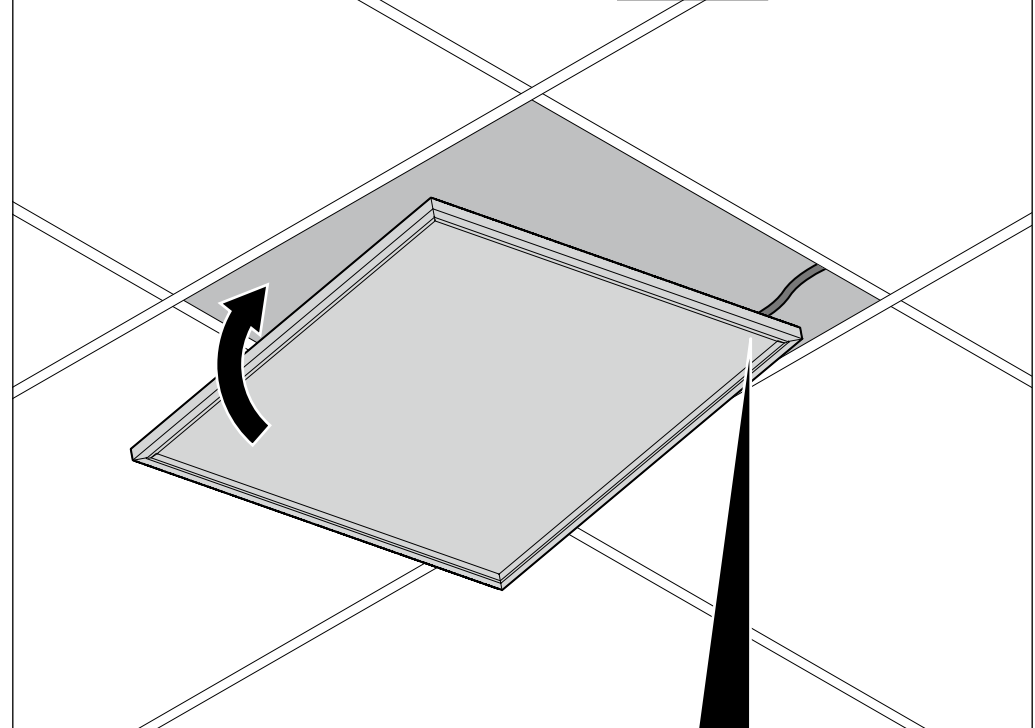
i





07

A

B

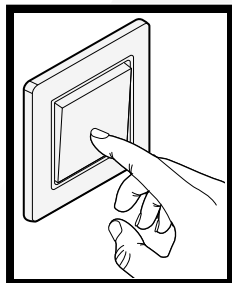

08

A

B



1.

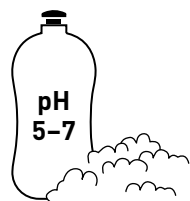

2.

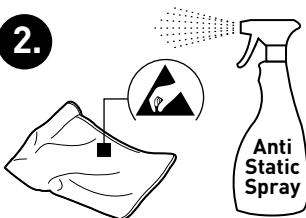

TRILUX GmbH & Co. KG

Heidestraße  
D-59759 Arnsberg  
+49 2932 301-0  
info@trilux.com  
www.trilux.com