

Montageanleitung

Ⓒ mounting instruction Ⓕ Notice de montage Ⓒ Instrukcja montażu
Ⓔ Instrucciones de montaje Ⓘ Istruzioni di montaggio

EL - EU ... MRM

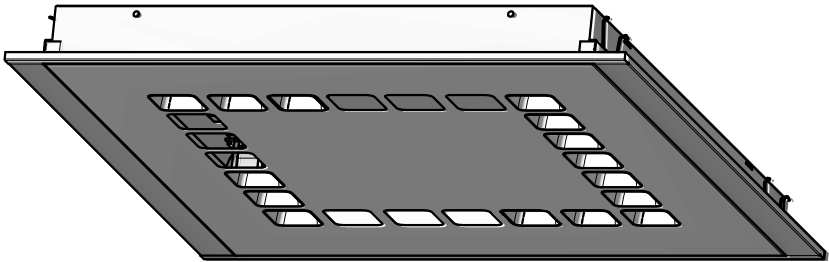

RIDI Leuchten GmbH
Hauptstrasse 31 - 33 · D-72417 Jungingen
Tel. 07477/872-0 · Fax 07477/872-48
kontakt@ridi.de · www.ridi.de



- (D) Für die Installation und für den Betrieb der Leuchten sind die nationalen Sicherheitsvorschriften zu beachten.
- (GB) Please note national safety instructions for installation and operation of this luminaire.
- (F) Pour l'installation et le fonctionnement des luminaires il est impératif de respecter les normes nationales de sécurité en vigueur.
- (PL) W celu prawidłowej instalacji i poprawnego działania oprawy należy przestrzegać krajowych przepisów bezpieczeństwa.
- (E) Para la instalación y la puesta en funcionamiento de las luminarias deben observarse las normas nacionales de seguridad.
- (I) Per l'installazione e il funzionamento delle lampade si fa riferimento alle normative di sicurezza nazionali.

- (D) Die Lichtquelle dieser Leuchte darf nur vom Hersteller oder einem von ihm beauftragten Servicetechniker oder einer vergleichbar qualifizierten Person ersetzt werden.
- (GB) Only the manufacturer, a trained service technician or another equally qualified person is permitted to replace the light source of this luminaire.
- (F) La source lumineuse de ce luminaire ne peut être remplacée que par le fabricant, un technicien de service mandaté par celui-ci ou une personne présentant une qualification analogue.
- (PL) Wymiany źródła światła w tej oprawie oświetleniowej może dokonać wyłącznie producent bądź uprawniony pracownik serwisu albo osoba o podobnych kwalifikacjach.
- (E) La fuente de luz de esta luminaria solamente podrá ser sustituida por el fabricante o una persona designada por este, ya sea un técnico de servicio u otra persona debidamente cualificada.
- (I) La sorgente luminosa di tale lampada può essere sostituita solo dal produttore o da un tecnico di assistenza da questi designato oppure da personale dotato di qualifica equivalente.

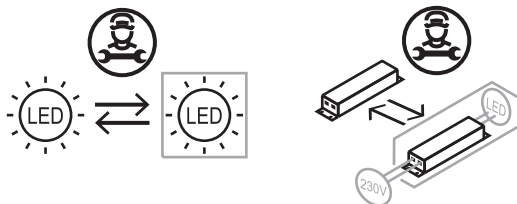
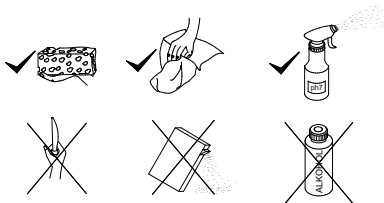

Druckfehler und Irrtum vorbehalten.
Formelle und technische Änderungen behalten wir uns vor.

Misprints and errors excepted.
We reserve the right of formal and technical modifications.

EL - EUE...MRM

L	B	Ls	Bs	K	$K_{(EDS)}$
1199	299	1200	300	L/2	x
1249	312	1250	312,5		x

EL - EUQ...MRM

L	B	Ls	Bs	K	$K_{(EDS)}$
599	599	600	600	120	x
624	624	625	625		x

EL - EUE...MRM

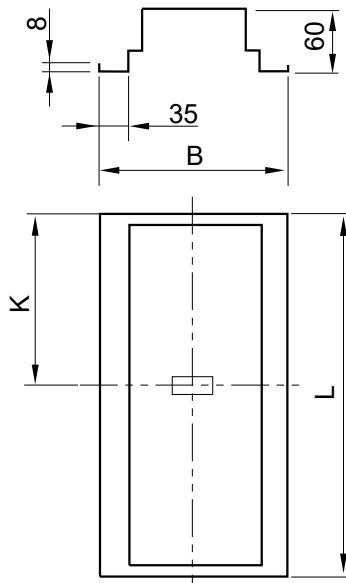

EL - EUQ...MRM

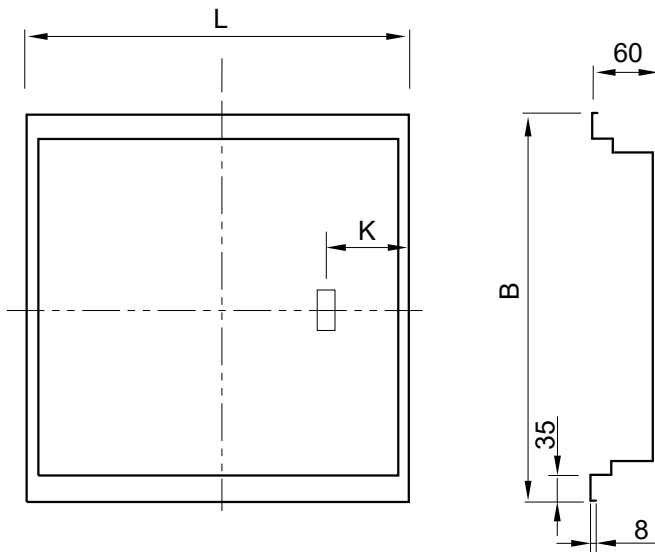

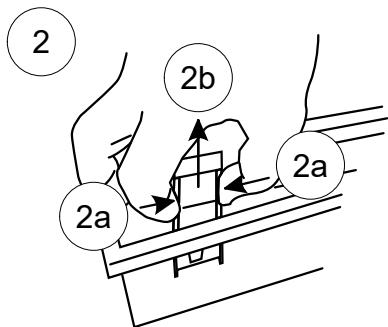
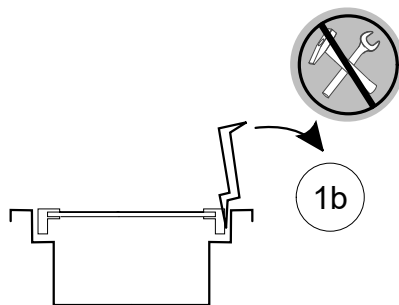
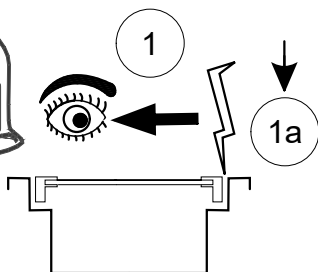
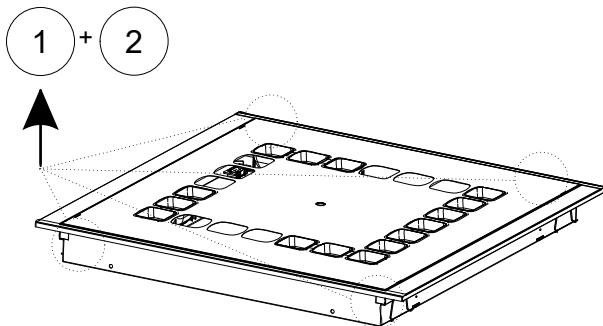

 → EL-EUE...MRM ... EDS
 EL-EUQ...MRM ... EDS

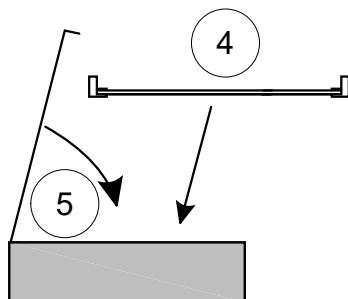
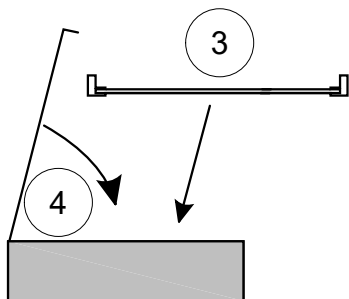
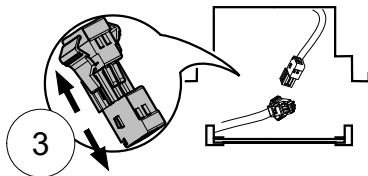

EL - EUE...MRM
 EL - EUQ...MRM

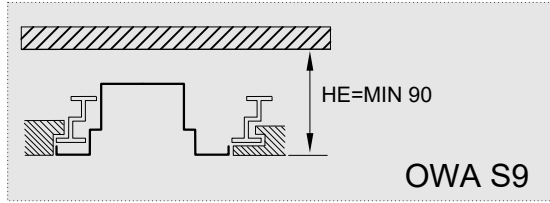

Typ	Nr.
EL-EUE...MRM 1199...	1210144 ZBS-EUE-OWA-S9 M600
EL-EUE...MRM 1249...	1210145 ZBS-EUE-OWA-S9 M625
EL-EUQ...MRM 599...	1210140 ZBS-EUQ OWA-S9 M600
EL-EUQ...MRM 624...	1210142 ZBS-EUQ OWA-S9 M625

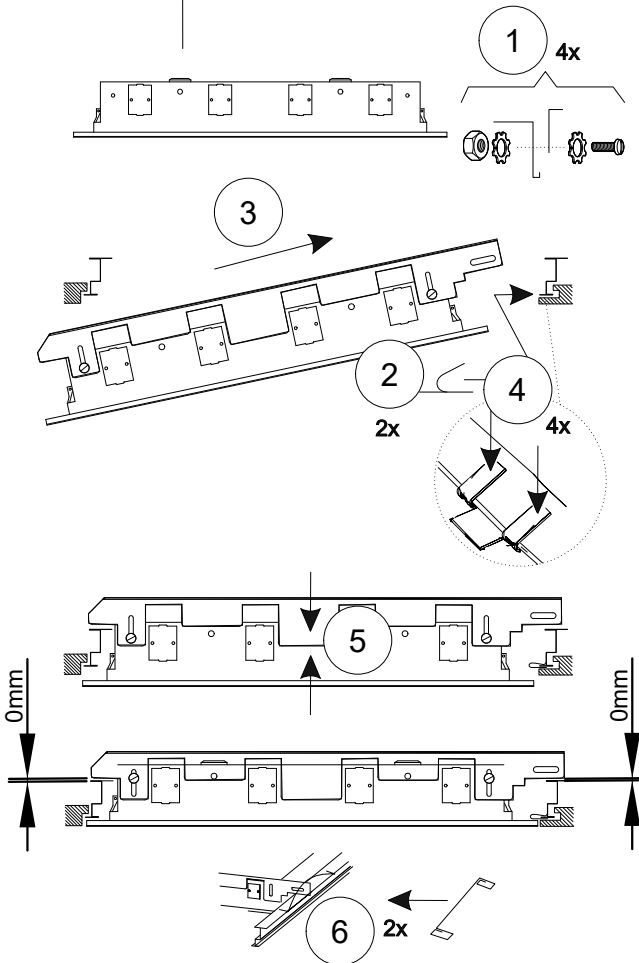
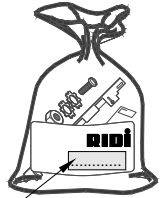

EL - EUE...MRM
 EL - EUQ...MRM

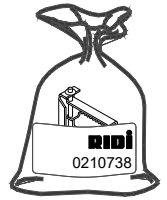
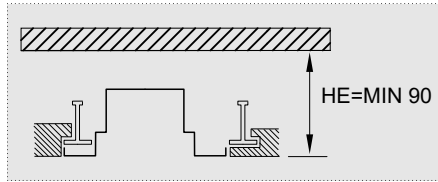

0210738
 ZBS-EU M600-M625

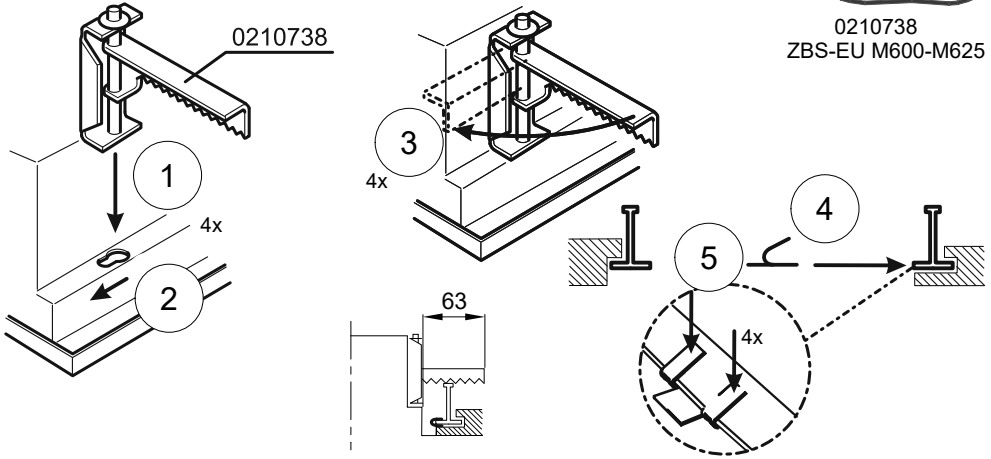

~~EL - EUE...MRM~~
~~EL - EUQ...MRM~~

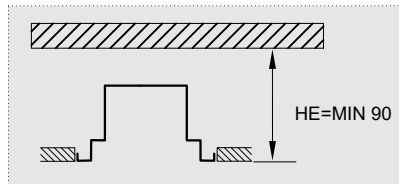

0210127
 ZBS-E BR 10-127

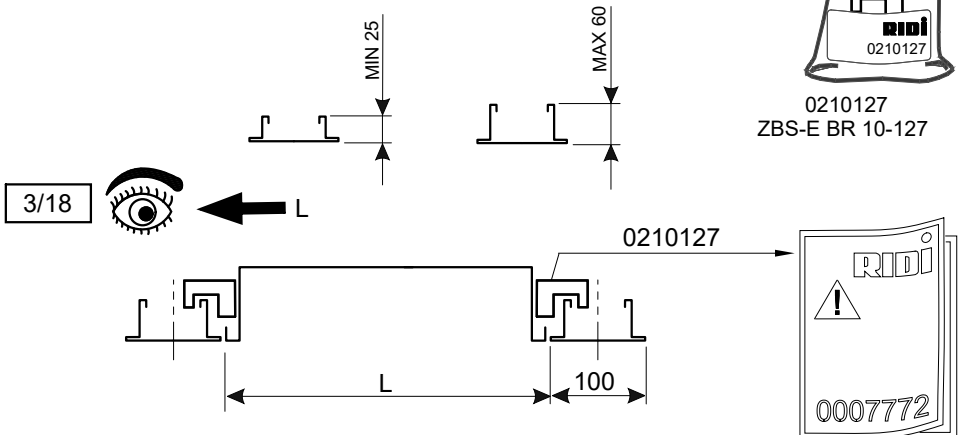

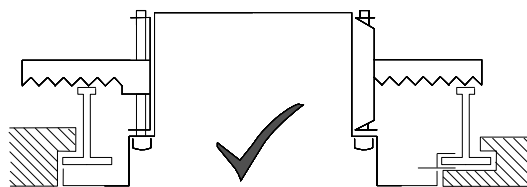
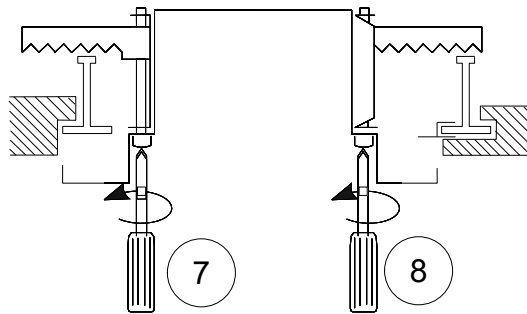
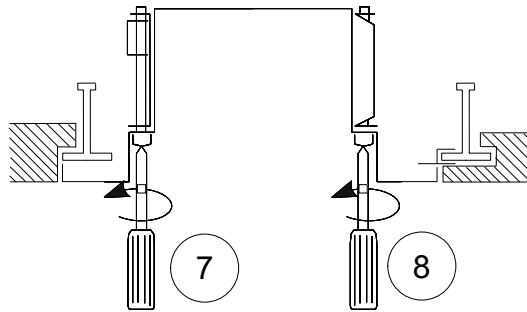
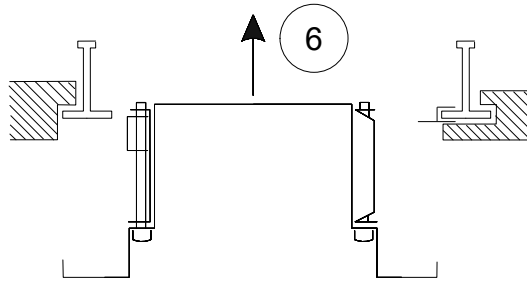

Keine Isolierung
No insulation
Pas d'isolation
Brak izolacji
Sin aislamiento
Nessun isolamento

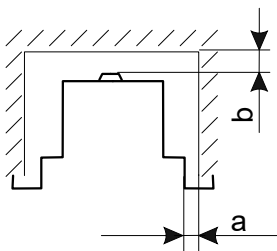
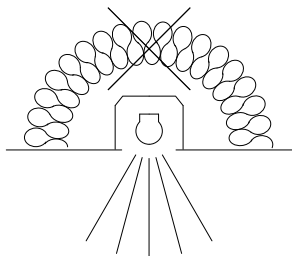

$a_{min} = 63 \text{ mm}$

$b_{min} = 30 \text{ mm}$

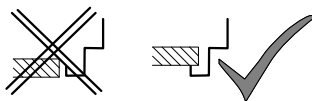
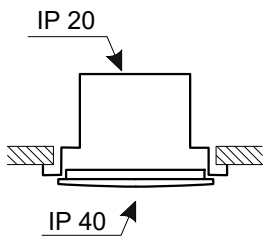

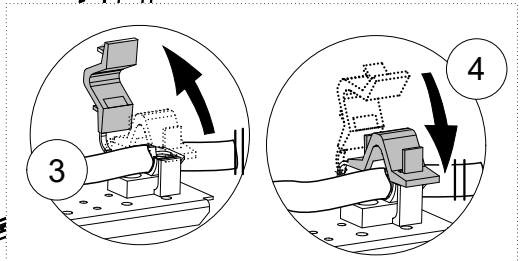
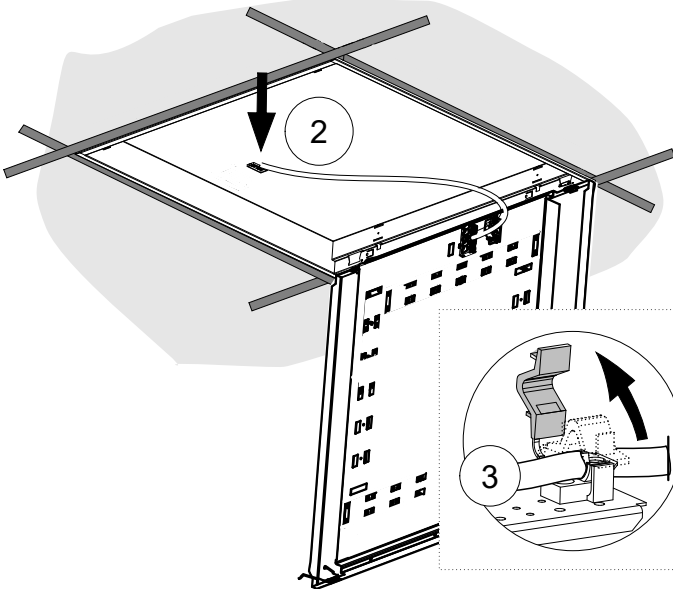
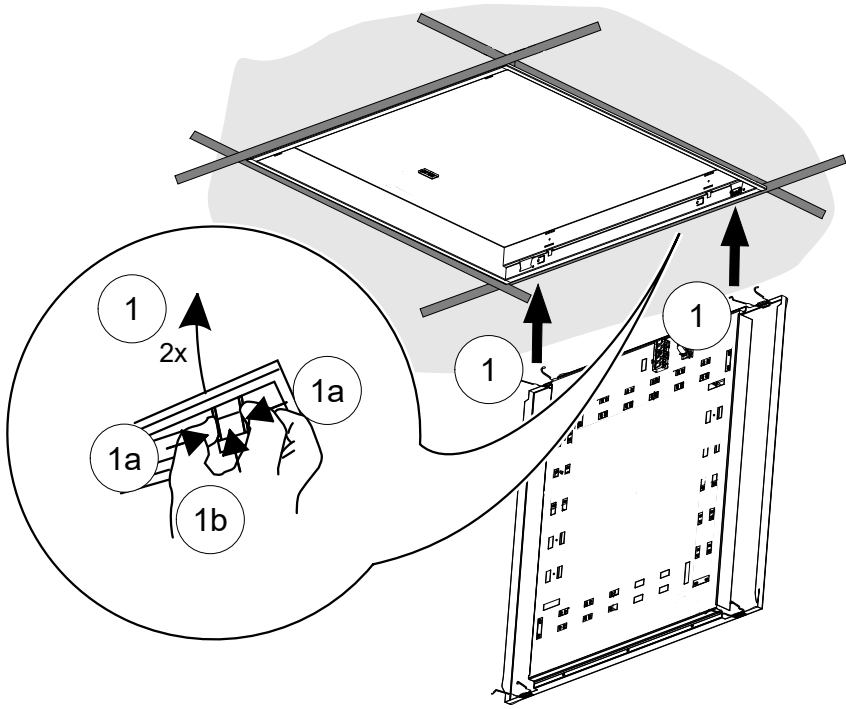

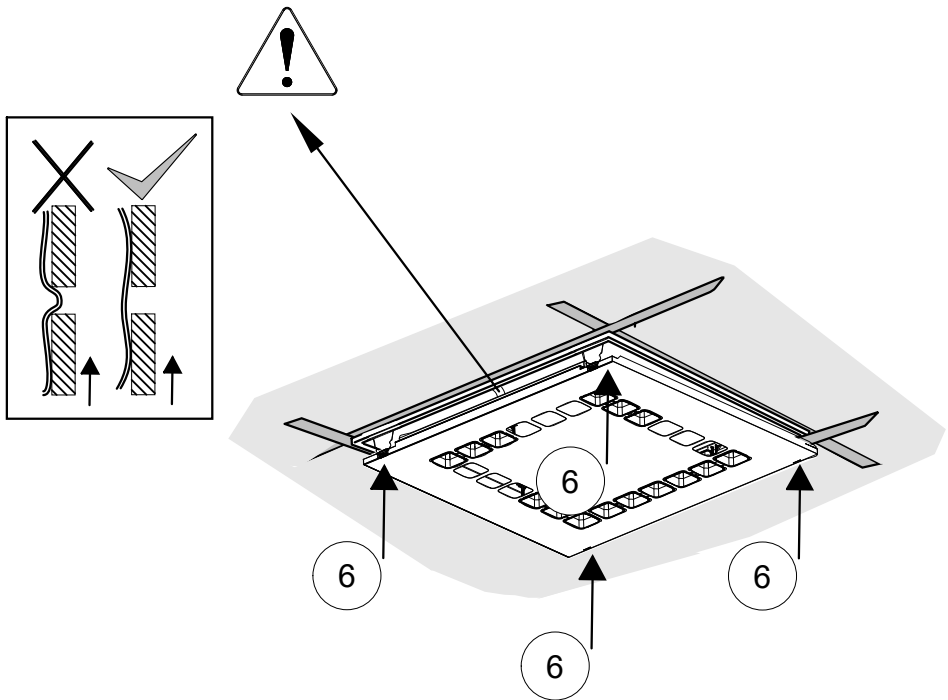
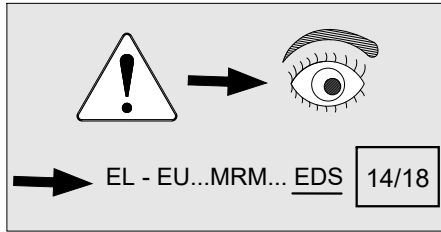

LINECT

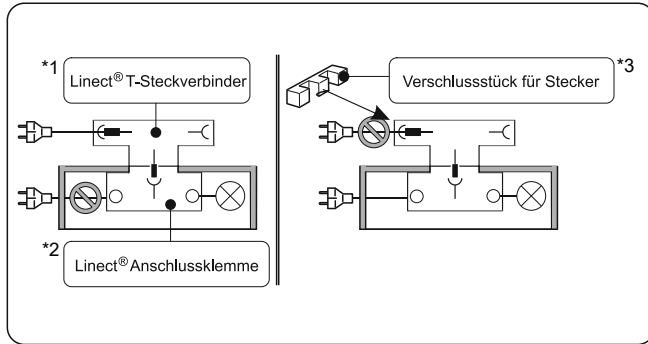

(GB) *1 Plug connector *2 Connector block *3 Locking piece for plug

(F) *1 Connecteur *2 Borne de raccordement *3 Obturateur pour connecteur

(PL) *1 Wtyk *2 Zacisk przyłączeniowy *3 Zamknięcie wtyku

(E) *1 Conector *2 Borne de conexión *3 Tapa de bloqueo para enchufe

(I) *1 Connettore elettrico *2 Morsetto di collegamento *3 Coperchio per connettore

(D) Verbinden und Trennen nur ohne Last
Nur für den Einsatz in nicht leicht zugänglichen Bereichen

(GB) Only connect and disconnect without load
Only for use in areas that are difficult to access

(F) Liaison et séparation seulement sans charge
Seulement pour une utilisation dans des zones peu accessibles

(PL) Nie wolno łączyć ani rozłączać pod obciążeniem
Do zastosowania tylko w obszarach o utrudnionym dostępie

(E) Conectar y desconectar solo sin carga
Solo para uso en áreas de difícil acceso

(I) Collegare e separare solo senza carico
Solo per l'utilizzo in zone non facilmente accessibili

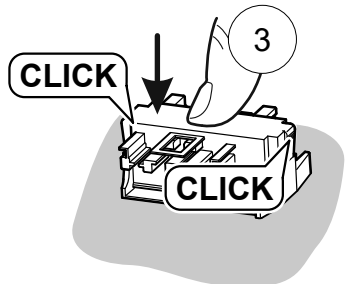
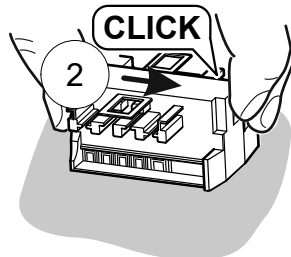
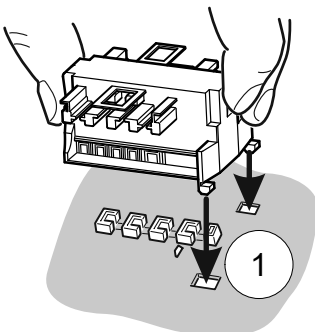

EL - EUE...MRM... EDS
EL - EUQ...MRM... EDS

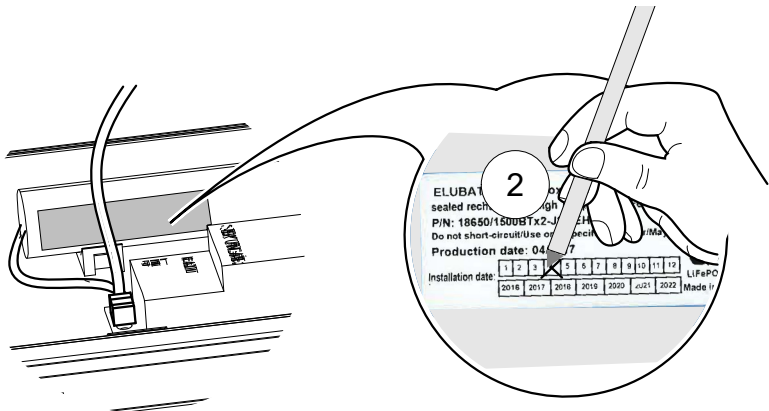
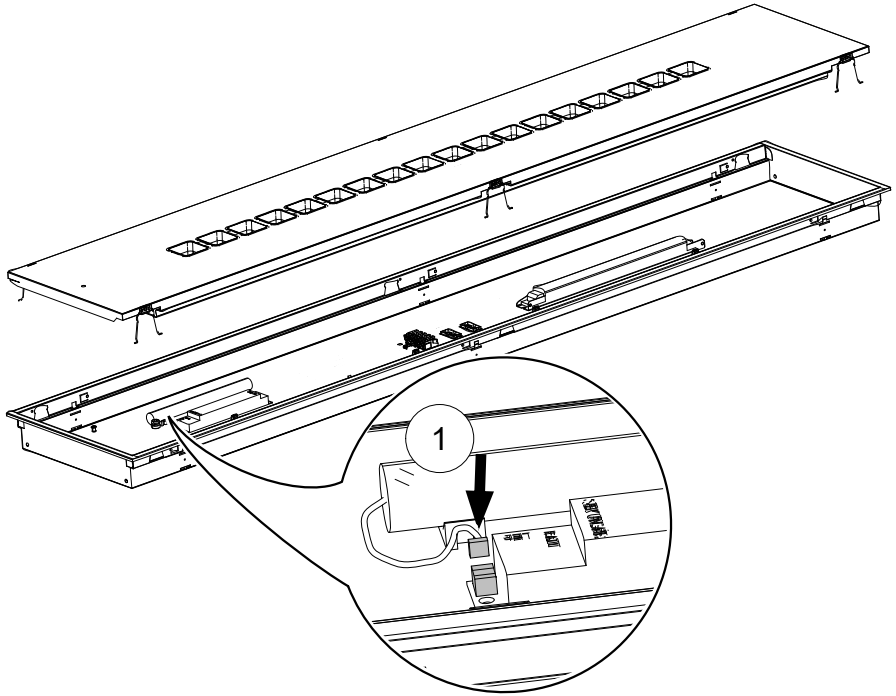

EL - EUE...MRM... EDS
EL - EUQ...MRM... EDS

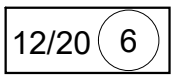
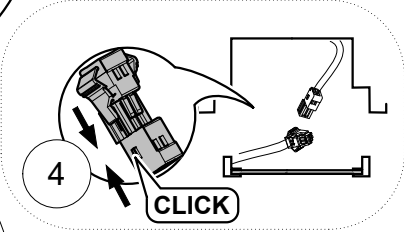
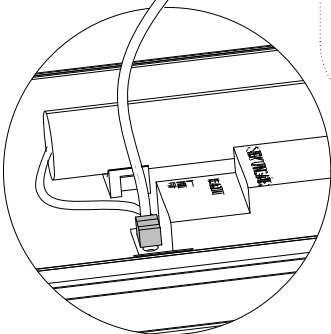
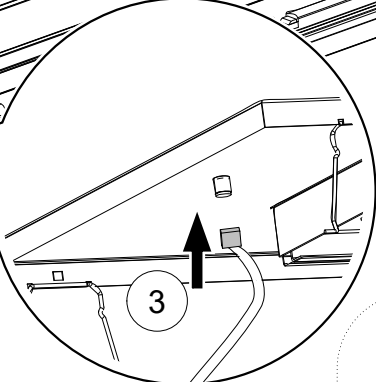
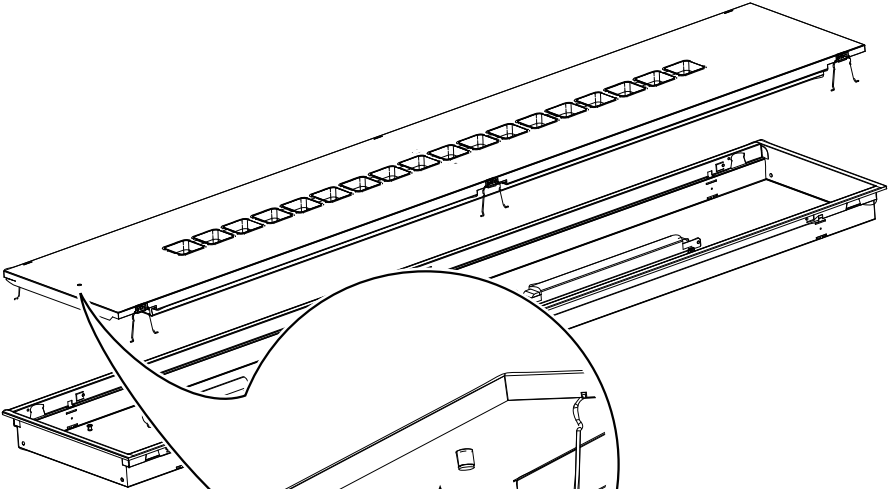

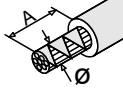
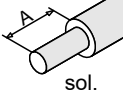
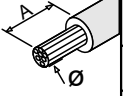
	Ø	A		mm ²	A		mm ²	A
	0,8-1,2	9	sol.	0,5-1,0	9		0,8-1,2	9
max. ø1,8mm	1,3-1,8	12	0,5-2,5mm ²	1,5-2,5	12	max. ø1,8mm	1,3-1,8	12

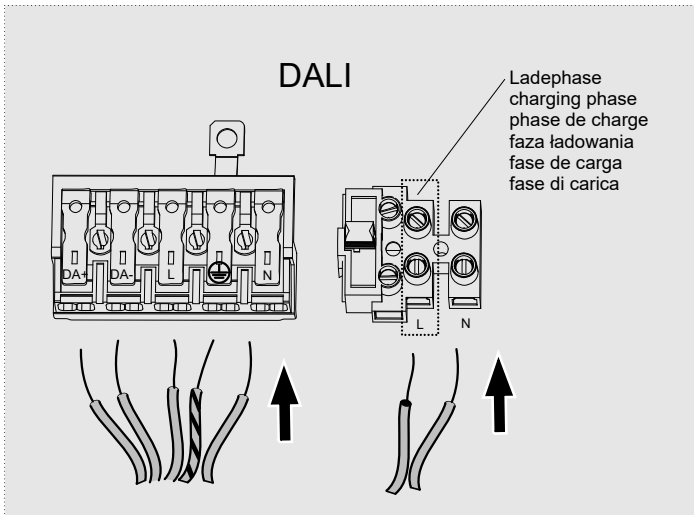
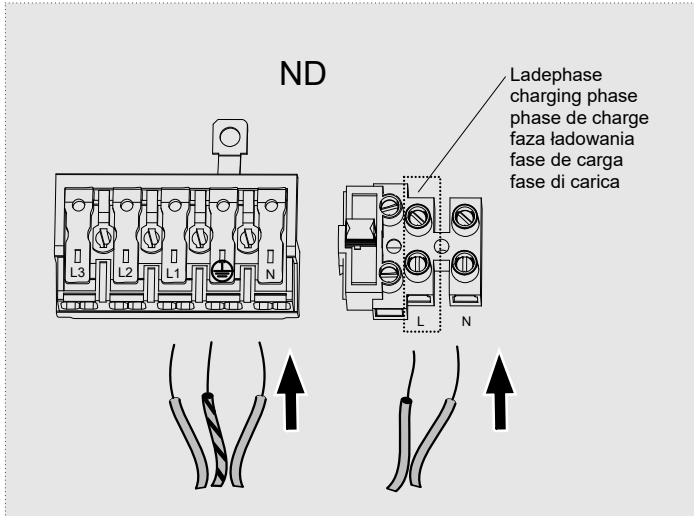



- Ⓓ Austausch nur mit der Original T 2,0A H 250 Sicherung
 - ⒼⒷ Warning: Only replace with the original T 2.0A H 250 V fuse
 - Ⓕ Attention, échange seulement avec le fusible original T 2,0A H 250
 - Ⓗ Uwaga, wymiana tylko na oryginalny bezpiecznik T 2,0 A H 250
 - Ⓔ Atención: cambiar solo por el fusible original T 2,0A H 250
 - Ⓘ Attenzione: cambio solo con il fusibile originale T 2,0A H 250
-

1

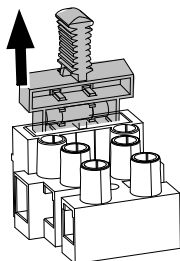

2

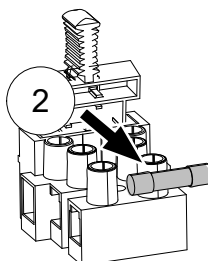

4

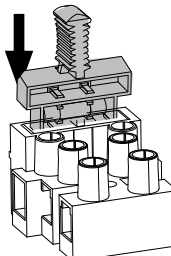
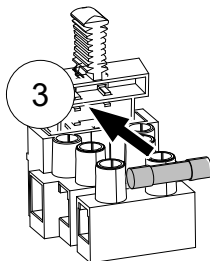

EL - EUE...MRM... EDS
EL - EUQ...MRM... EDS

