



**AQFPRO PC/PM**  
- AQFPRO S (TW)  
- AQFPRO L (TW)

**BC (Bluetooth® CASAMBI)**  
**MWBC (presence detector + Bluetooth® CASAMBI)**  
**MWCFBC (presence detector + Corridor Function**  
**+ Bluetooth® CASAMBI)**

**AQFPRO PC (not with AQFPRO PM)**  
- AQFPRO S (QC3/QC5/QCTW)  
- AQFPRO L (QC3/QC5/QCTW)



**EN Mounting instructions**  
Important notices. Please, read first! Keep the instructions safe! Specifications are subject to change without notice! If you have questions, please contact the manufacturer.

**DE Montageanleitung**  
Wichtige Hinweise. Bitte zuerst lesen! Anleitung aufbewahren! Technische Änderungen vorbehalten! Bei Fragen wenden Sie sich an den Hersteller.

**FR Notice de montage**  
Remarques importantes. À lire en premier lieu! Conservez cette notice! Modifications techniques sans préavis! Si vous avez des questions, veuillez contacter le fabricant.

**IT Istruzioni di montaggio**  
Nota importanti. Si prega di leggere prima! Conservare le istruzioni! Modifiche tecniche senza preavviso! Per chiarimenti rivolgersi al produttore.

**ES Instrucciones de montaje**  
Notas importantes. Por favor, lea primero! ¡Guarde las instrucciones! ¡Reservado el derecho de realizar modificaciones técnicas sin preaviso! Si tiene alguna pregunta, póngase en contacto con el fabricante.

**NL Montagehandleiding**  
Belangrijke informatie. Gelieve eerst te lezen! Houd deze gebruiksaanwijzingen zorgvuldig bij! Technische wijzigingen blijven voorbehouden! Als u vragen hebt, kan u contact opnemen met de fabrikant.

**SV Installationsanvisning**  
Viktigt information. Läs först! Spara anvisningen! Med reservation för tekniska ändringar! Om du har frågor ber vi dig ta kontakt med tillverkaren.

**FI Asennusohje**  
Tärkeä huomautus. Lue ensin! Säilytä käyttöohje! Oikeudet teknisiin muutoksiin pidätetään! Lähetä mahdolliset kysymykset valmistajalle.

**RU Инструкция по монтажу**  
Важная информация. Просьба ознакомиться перед началом работ! Сохраняйте инструкции! Компания сохраняет за собой право на внесение технических изменений. При возникновении вопросов обращайтесь к производителю.

**PL Instrukcja montażu**  
Ważne wskazówki/ uwagi. Proszę pierwsze przeczytać całość instrukcji. Proszę zachować instrukcję! Zastrzega się prawo do wprowadzania zmian technicznych. W razie pytań skontaktuj się z producentem.

**ZH 安装说明**  
重要提示。请先阅读！保留本说明！  
请勿执行技术变动！  
如有问题，请咨询制造商。

**AR تعليمات التركيب**  
ملاحظات هامة. يرجى القراءة أولاً!  
إبقاء التعليمات!  
تخضع المواصفات للتغيير دون تقديم إشعار!  
إذا كان لديك أسئلة، الرجاء الاتصال بالشركة المصنعة.

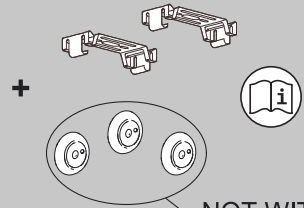
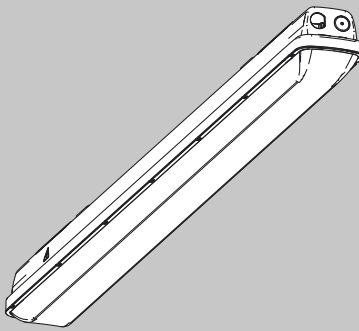

NOT WITH  
AQFPRO PC QC3/QC5/QCTW

## i OPTIONS



[www.thornlighting.com/AQUP](http://www.thornlighting.com/AQUP)



MWS/MWCF (pages 5-7):  
presence detector  
presence detector + Corridor Function  
MWBC/MWCFBC (page 7):  
MWS + Bluetooth® CASAMBI)  
MWS + Corridor Function  
+ Bluetooth® CASAMBI)

TW (pages 10+11):  
Through Wiring

QC3/QC5/QCTW (pages 12+13):  
Quick Connect (AQFPRO PC ONLY)

E3, E3D, E3D (UK):  
Emergency options (pages 14+15)

## i BC (Bluetooth® CASAMBI)

### Website

### Handbook

### Planning Notes Wireless

[www.tridonic.com/basicdim-wireless](http://www.tridonic.com/basicdim-wireless)



EN



DE



## i MOUNTING OPTIONS

Wall/Ceiling (page 9)

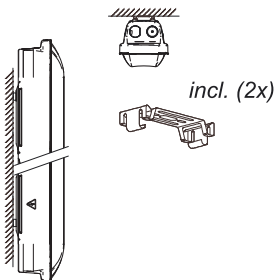

Chain (page 9)

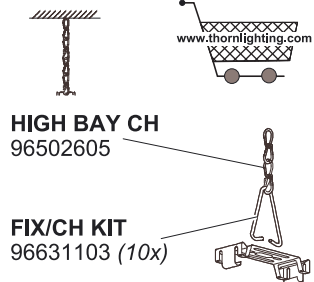

## i SEALING GROMMET

22157839



50x

HOLDER FOR THROUGH WIRING

96631102



1x

## MOUNTING SET Aquaforce Pro

96631127



3x

+

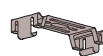

2x



**i****IP66****IK08**  
(PC)**IK03**  
(PMMA)

\*only

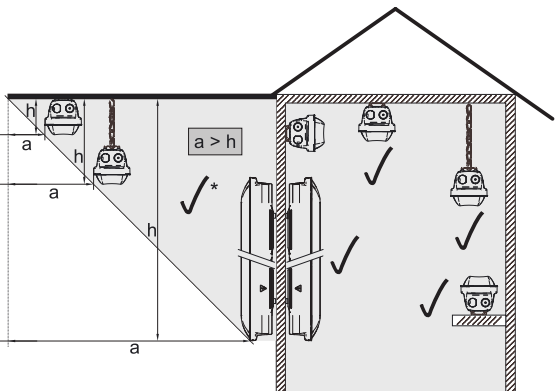
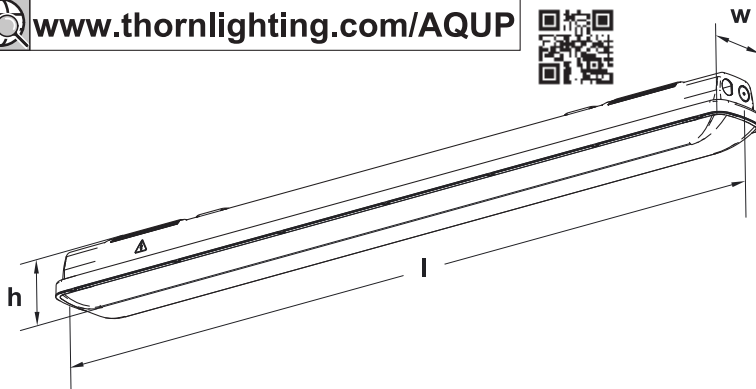
AQFPRO PC (-20°C - +40°C)  
AQFPRO PM (-10°C - +35°C)AQFPRO S LED2900  
AQFPRO S LED4300  
AQFPRO S LED5200  
AQFPRO L LED4300  
AQFPRO L LED6400  
AQFPRO L LED8000  
AQFPRO L LED10000**i**[www.thornlighting.com/AQUP](http://www.thornlighting.com/AQUP)

	l	w	h	m	OPTIONS
AQFPRO S	1100 mm	91,5 mm	90 mm	1,7 kg	www.*
AQFPRO L	1600 mm	91,5 mm	90 mm	2,1 kg	www.*

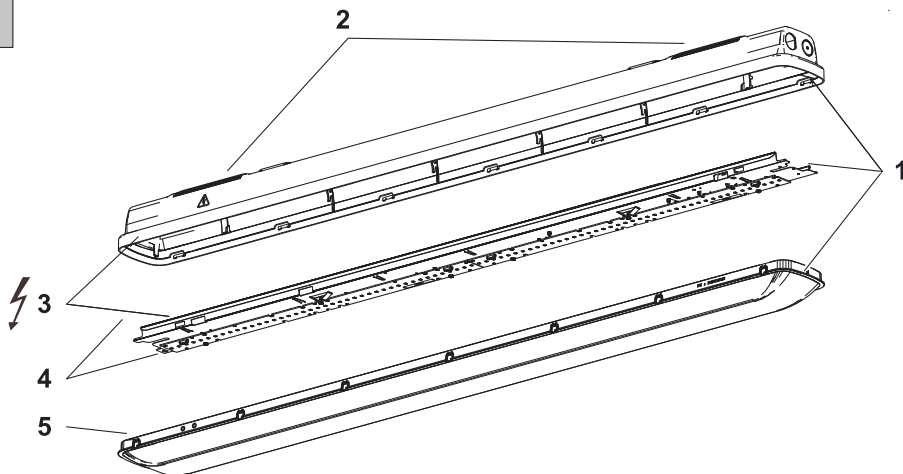
**i**

1a

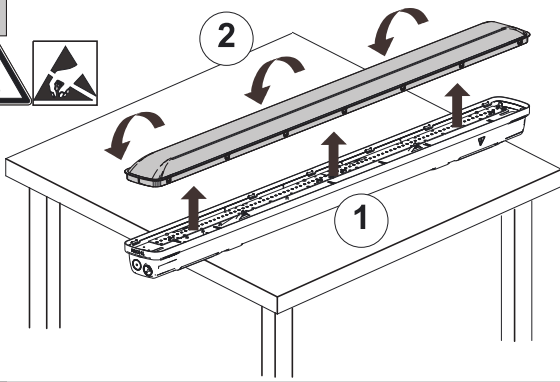

**DO NOT OPEN**  
AQFPRO PC ...  
QC3/QC5/QCTW!

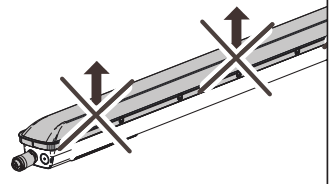

AQFPRO PC ...  
QC3/QC5/QCTW →

2

1b



a

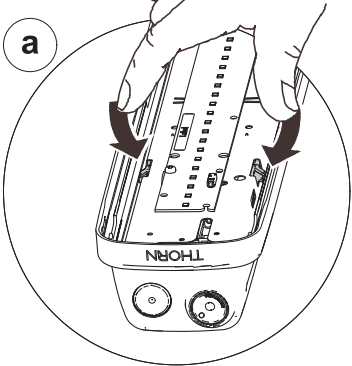

b

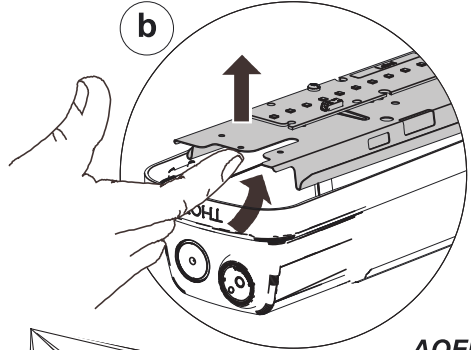

AQFPRO S: 4x  
AQFPRO L: 6x

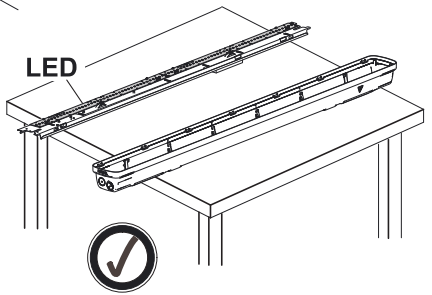
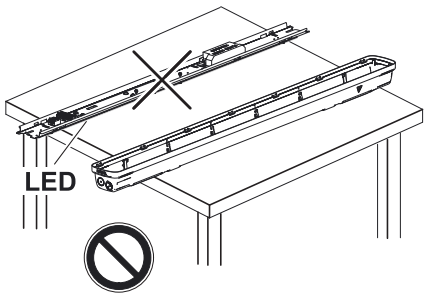
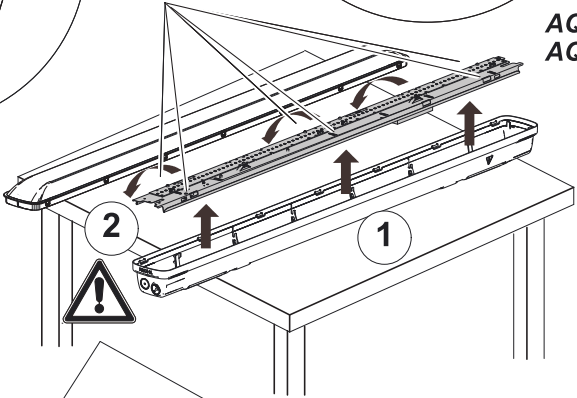



**1c** OPTION SENSOR MWS + MWCF (TRIDONIC 28002214)

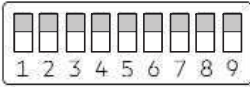
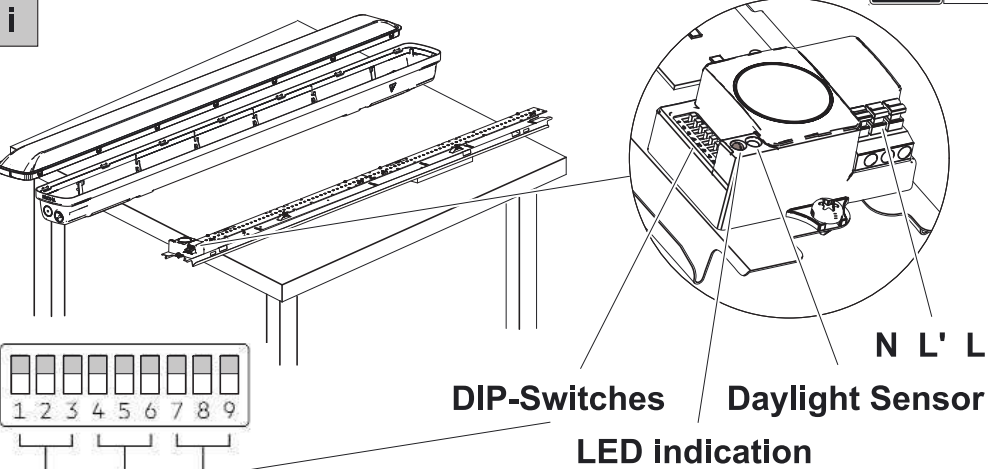

Hold time  
Daylight  
threshold

**Sensitivity**



[www.tridonic.com/28002214](http://www.tridonic.com/28002214)



01/18-15011865-1 We reserve the right to make technical changes without prior notice.  
Tridonic GmbH & Co KG, [www.tridonic.com](http://www.tridonic.com), [info@tridonic.com](mailto:info@tridonic.com), Tel. +43 5572 395-0

**i** **Wiring Diagrams (MWS, MWCF)**

**ON/OFF (MWS) Standalone**

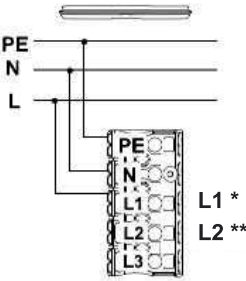

\*L1 = L .. permanent line  
\*\*L2 = L' .. switched line

**ON/OFF (MWS) Initiator-Follower**

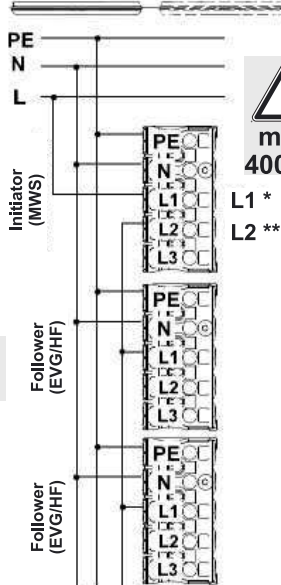

**Corridor Function (MWCF) Initiator-Follower**

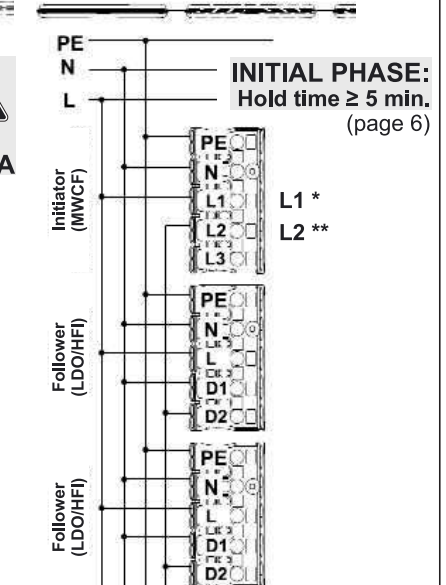



i Motion detection area

Ceiling mounted

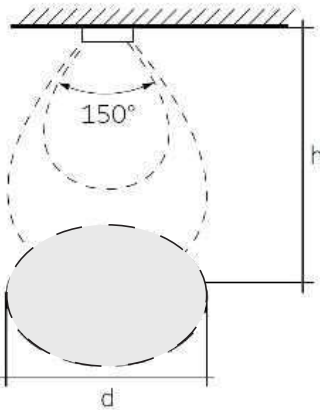

Wall mounted

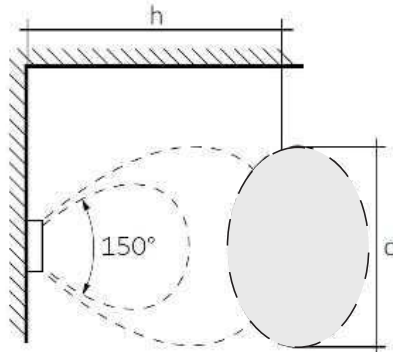

h	d
0.5m	0.5 m
1.0m	1.0m
1.5m	2.0 m
2.0m	4.0m
2.5m	6.0m
3.0m	7.0 m
3.5 m	6.0m
4.0m	5.0m
4.5 m	4.0 m
5.0 m	3.0 m



**Values may differ significantly!**

Reflected HF waves (e.g. of walls, floors, ceilings or furniture) from other transmitters affect motion detection.



[www.tridonic.com/28002214](http://www.tridonic.com/28002214)



i

	1	2	3	Sensitivity
I	<input checked="" type="radio"/>	<input checked="" type="radio"/>	<input checked="" type="radio"/>	100 % (default)
II	<input type="radio"/>	<input checked="" type="radio"/>	<input checked="" type="radio"/>	75 %
III	<input type="radio"/>	<input checked="" type="radio"/>	<input type="radio"/>	50 %
IV	<input type="radio"/>	<input type="radio"/>	<input checked="" type="radio"/>	30 %
V	<input type="radio"/>	<input type="radio"/>	<input type="radio"/>	10 %



	4	5	6	Hold time
I	<input checked="" type="radio"/>	<input checked="" type="radio"/>	<input checked="" type="radio"/>	5 s (default)
II	<input checked="" type="radio"/>	<input type="radio"/>	<input checked="" type="radio"/>	30 s
III	<input checked="" type="radio"/>	<input type="radio"/>	<input type="radio"/>	1 min
IV	<input type="radio"/>	<input checked="" type="radio"/>	<input checked="" type="radio"/>	5 min
V	<input type="radio"/>	<input checked="" type="radio"/>	<input type="radio"/>	10 min
VI	<input type="radio"/>	<input type="radio"/>	<input checked="" type="radio"/>	20 min
VII	<input type="radio"/>	<input type="radio"/>	<input type="radio"/>	30 min



	7	8	9	Daylight threshold
I	<input checked="" type="radio"/>	<input checked="" type="radio"/>	<input checked="" type="radio"/>	Disable (default)
II	<input type="radio"/>	<input checked="" type="radio"/>	<input checked="" type="radio"/>	50 Lux
III	<input type="radio"/>	<input checked="" type="radio"/>	<input type="radio"/>	20 Lux
IV	<input type="radio"/>	<input type="radio"/>	<input checked="" type="radio"/>	5 Lux
V	<input type="radio"/>	<input type="radio"/>	<input type="radio"/>	2 Lux



# 1c OPTION SENSOR MWS + MWCF (TRIDONIC 28002214)



## i Distance between sensors

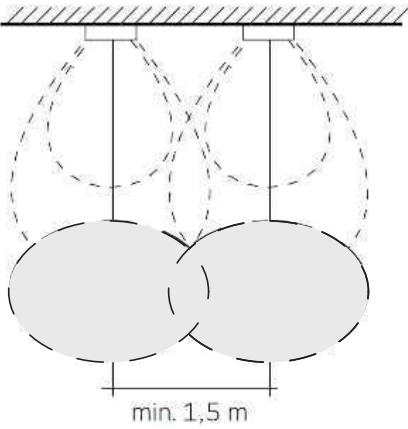

### Trouble Shooting Guide

(Problem => possible Reasons => Actions)

#### Fitting does not switch on

=> Brightness setting too low => Change setting

#### Fitting does not switch off

1. Continuous movements within detection area => Check area
2. Fitting is vibrating => Check surface and mounting

#### Fitting switches on without clear movements

1. Fitting is vibrating => Check surface and mounting
2. Non visible movements (behind a wall) => Check area

#### Fitting does not switch on despite clear movements

1. Detection area is too small => Check mounting instructions
2. Sensitivity is set too low => Extend sensitivity on sensor

#### Fitting does not dim down (in Corridor Function)

=> Corridor function is not activated => Check mounting instructions



[www.tridonic.com/28002214](http://www.tridonic.com/28002214)



## i Corridor Function (MWCF)

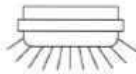

100% → 10%

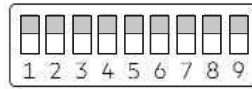

Hold time

(page 6)

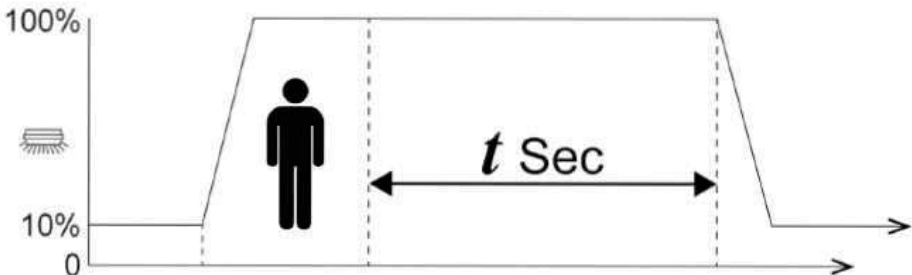

## i OPTION: BC (Bluetooth® CASAMBI)

BC (BC E3D)

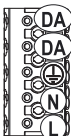

E3D ONLY!

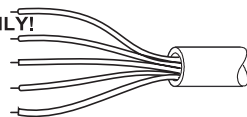

MWBC/MWCFBC

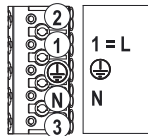

1 = L

N

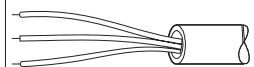

2



**IP66 DO NOT DRILL IN HOUSING!**

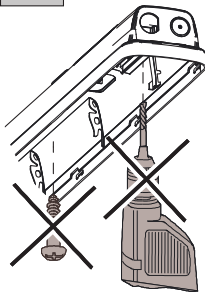

**IP66 CLOSE ALL OPENINGS!**

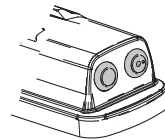
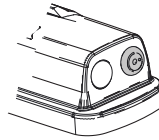

i

**SENSORS: MWS, MWCF**



**10 OPTIONS for MAINS IN\***

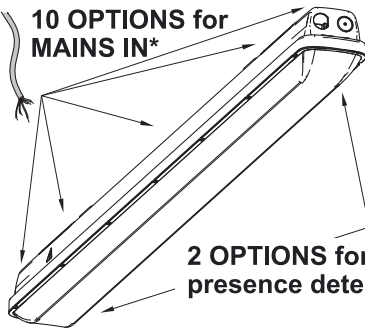

**2 OPTIONS for presence detector**

\* + 2 BESA box openings

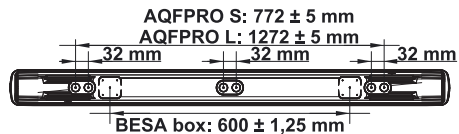

**2a OPTION 1x**

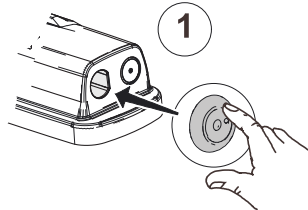

1

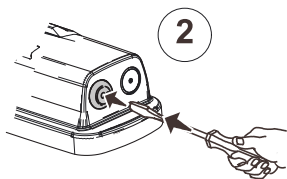

2

**OPTION 2-3x**

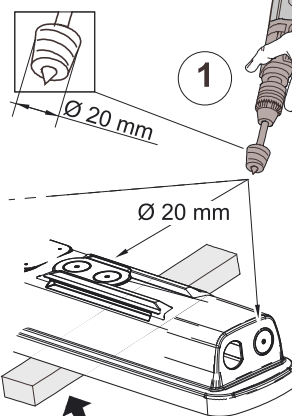

1

Ø 20 mm

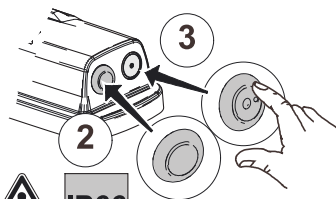

3

2



**IP66**

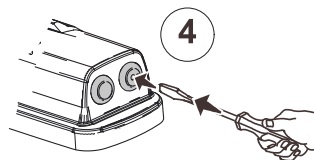

4

## 2b MOUNTING

### A) CEILING / WALL

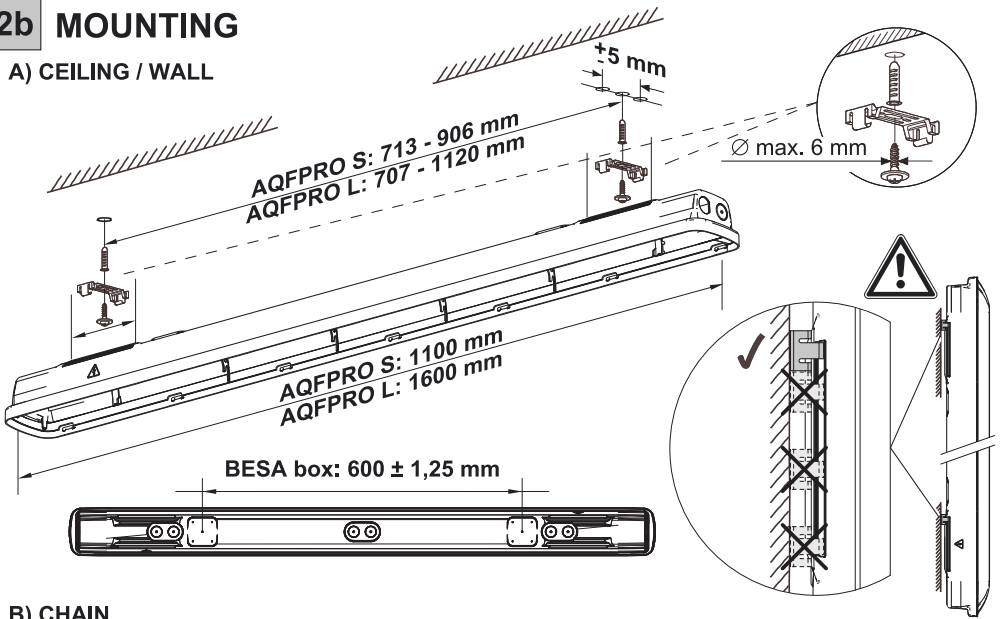

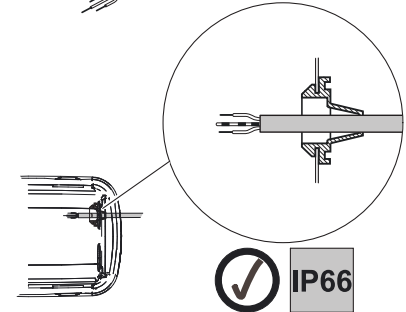
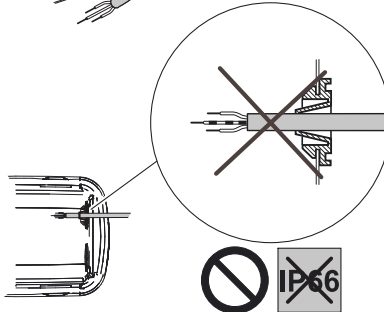
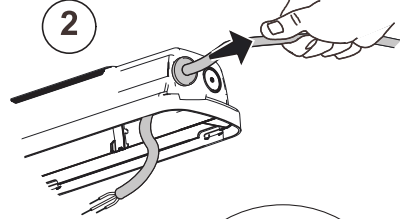
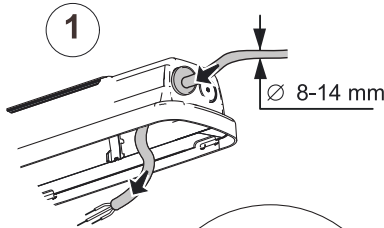
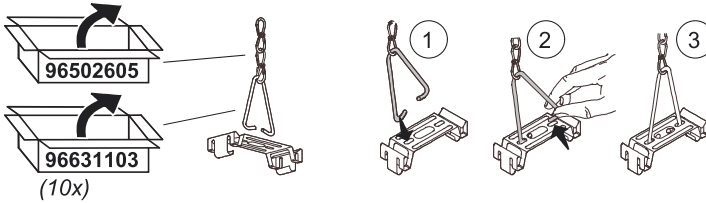

### B) CHAIN



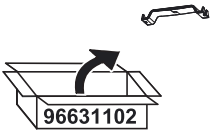

3 C) OPTION MAINS AND THROUGH WIRING by customer



 **NO THROUGH WIRING WITH**  
- AQFPRO S LED4300 E3  
 - AQFPRO L LED6400 E3

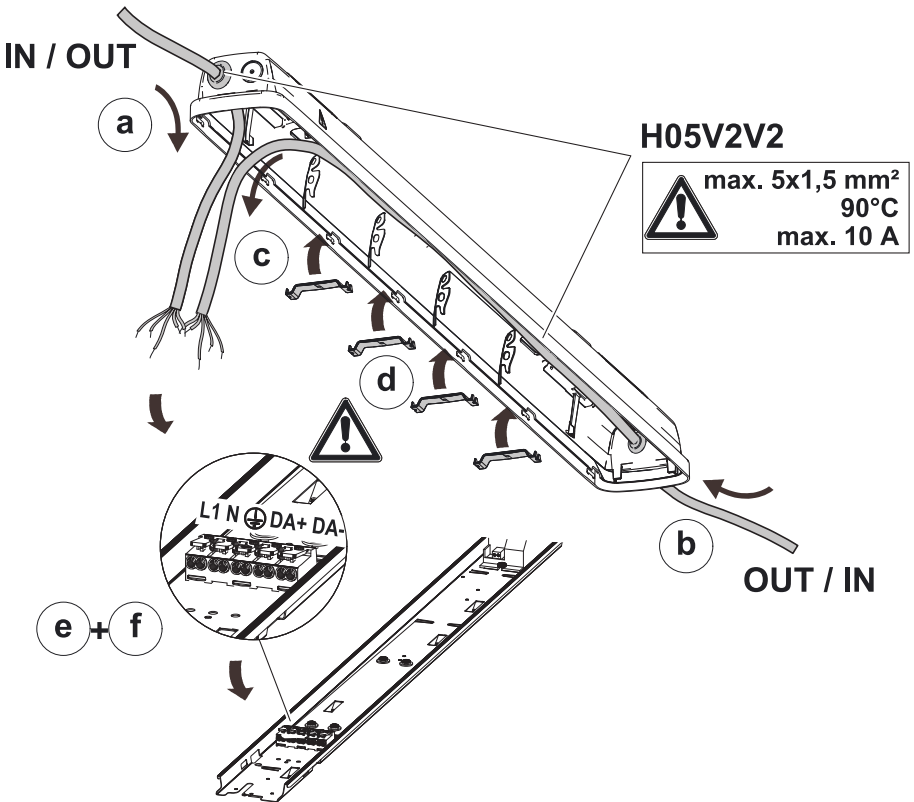

**3** D) OPTION MAINS FOR AQFPRO PC .. QC3/QC5 (QUICK CONNECT)

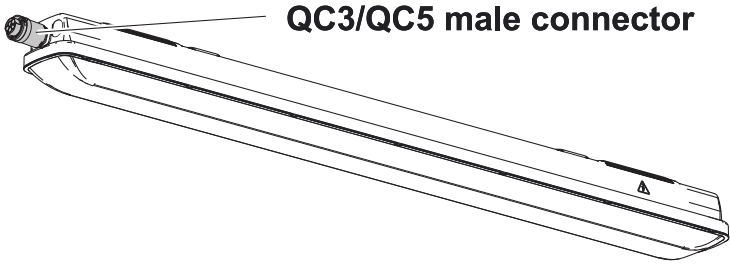

**QC3/QC5 male connector**

**3a**



**female connector**

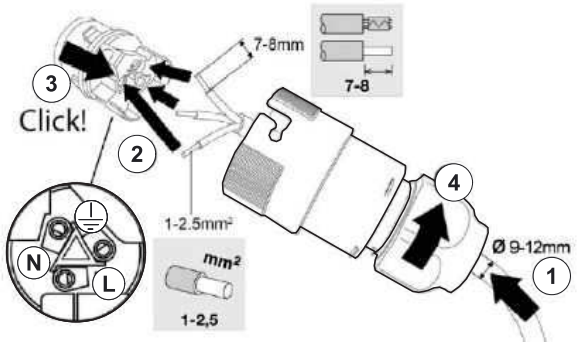

**3b**

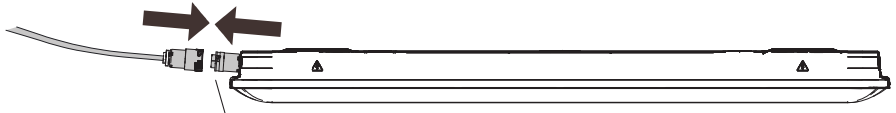

**female connector      male connector**

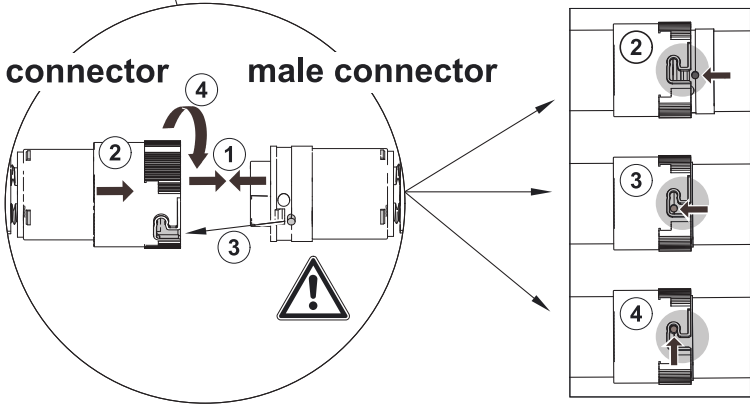



**3** E) OPTION MAINS FOR AQFPRO PC .. QCTW  
(QUICK CONNECT THROUGH WIRING)

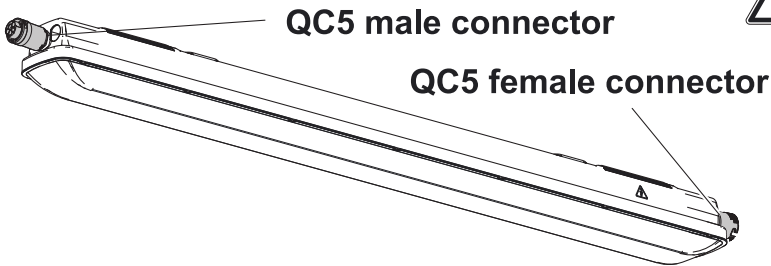

**3a**



+



**female connector  
male connector**

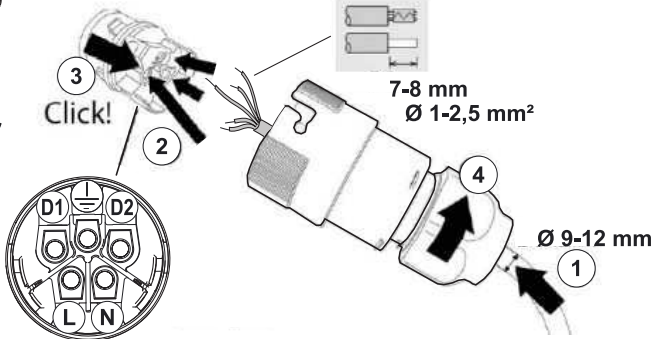

**3b**



**NO DIRECT QUICK CONNECT!**



**female connector      male connector**

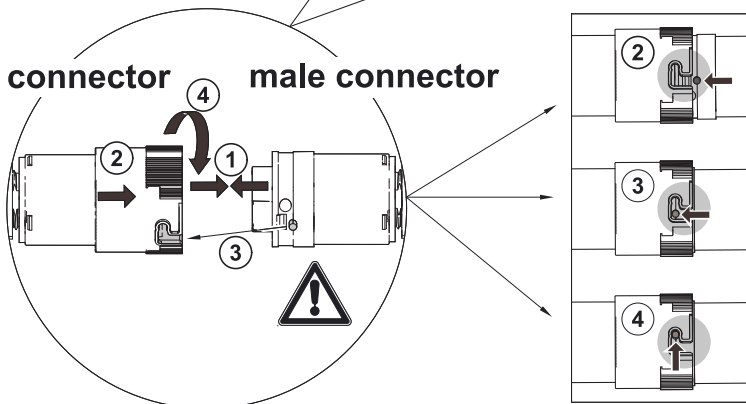

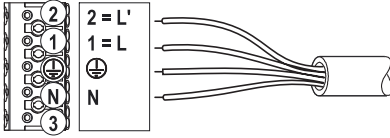
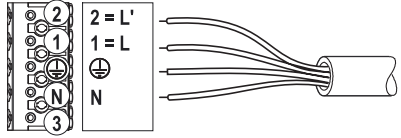
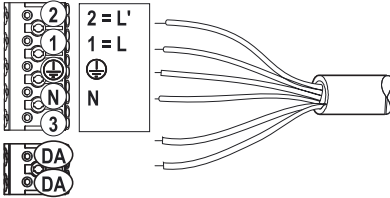
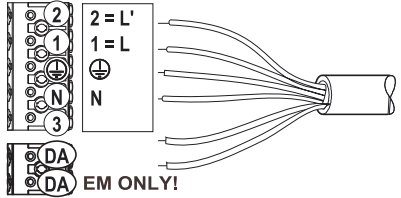
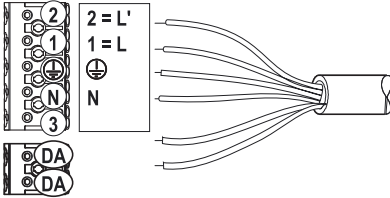
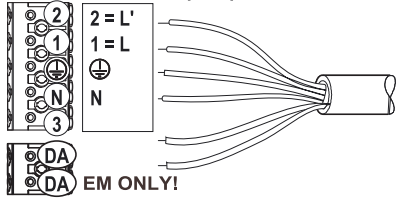
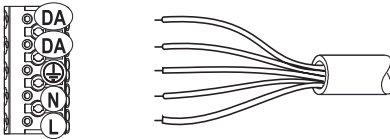
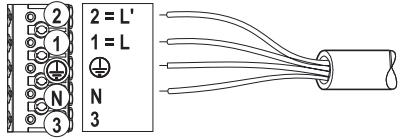
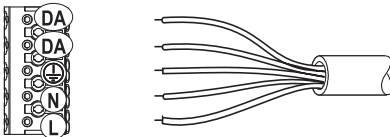
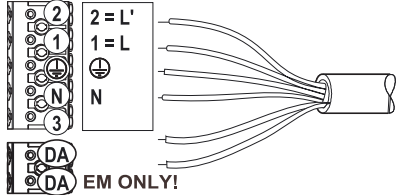
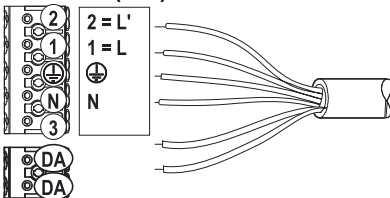
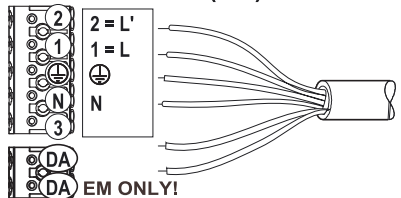
**OPTION: Emergency Lighting****OPTION: Emergency Light. with MWS/MWCF****i HF E3****i HF MWS-E3****i HF E3D****i HF MWS-E3D****i HF E3D (UK)****i HF MWS-E3D (UK)****i HFI E3****i HFI MWCF-E3****i HFI E3D****i HFI MWCF-E3D****i HFI E3D (UK)****i HFI MWCF-E3D (UK)**

**i** E3, E3D, E3D-UK

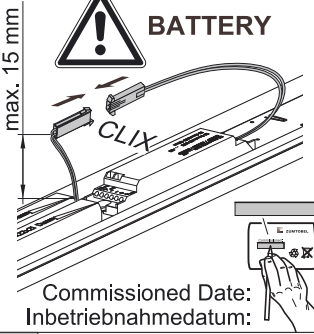

**E3, E3D, E3D (UK):  
CHANGE BATTERY INFORMATION**

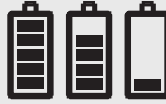

**DO NOT OPEN LUMINAIRE!**



**OPEN LUMINAIRE**

**i** ECD, ECP, ECC

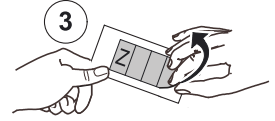
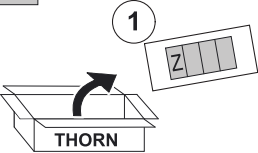

**4**

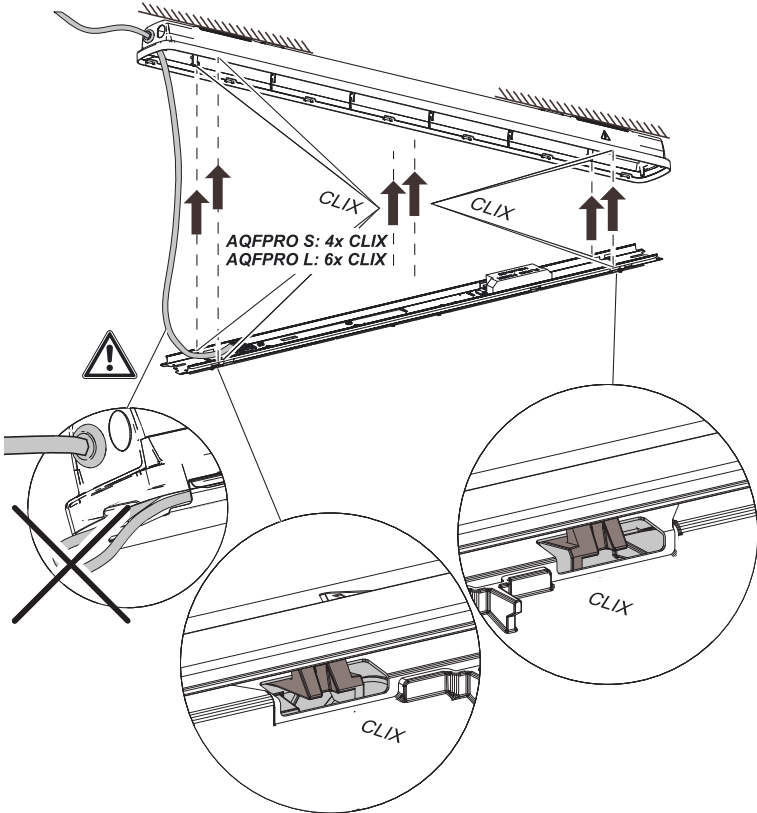

5

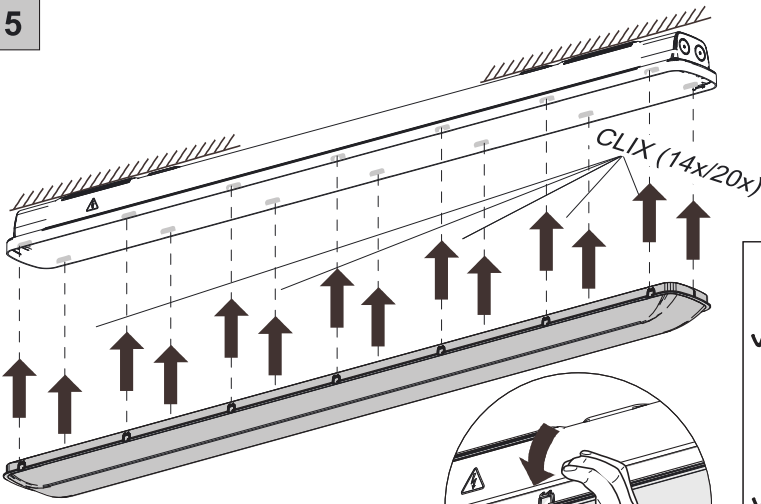

IP66

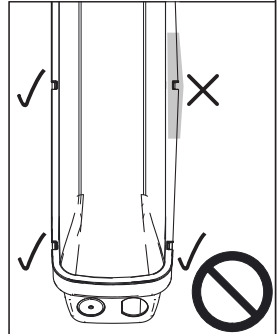

AQFPRO S: 14x  
AQFPRO L: 20x

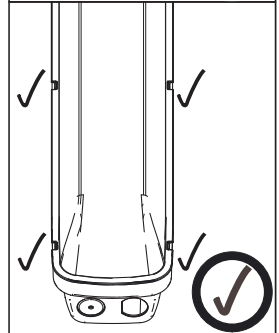
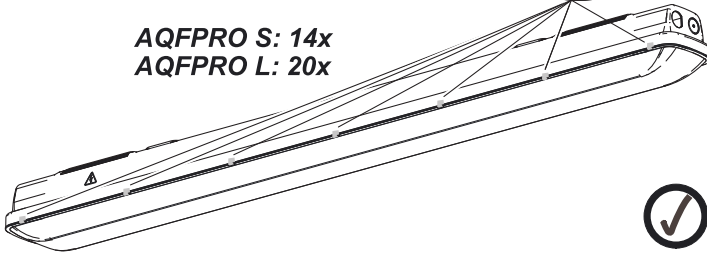

## i DISMOUNTING

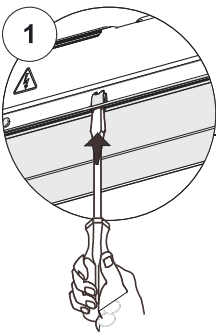

14x/20x

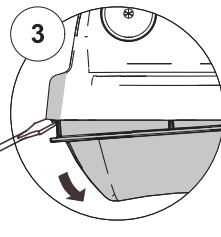
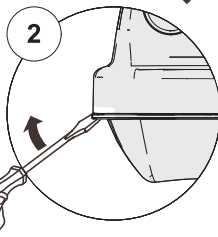
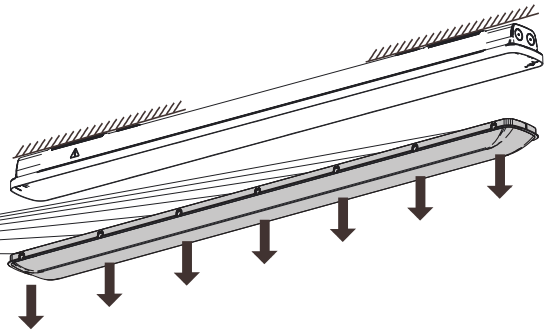

## **DE** Materialhinweis AQFPRO PC!

Chemische Einflüsse, sei es durch direkten Kontakt oder durch in der Atmosphäre schwebende Stoffe und ungeeignete Reinigungsmethoden können zu einer Beschädigung der Leuchte führen!  
Verwenden Sie keine mäßig bis stark laugen- und säurehaltigen Stoffe und keine Lösungsmittel oder Reinigungsmittel, welche Kunststoffe angreifen.

Änderungen vorbehalten! Bei Fragen wenden Sie sich an den Hersteller.

## **EN** Luminaire materials AQFPRO PC!

Aggressive chemicals, in direct contact with the luminaire or in the form of airborne substances can damage the fitting. So can unsuitable cleaning agents.  
Do not use medium-strength or concentrated alkaline or acidic solutions nor any solvents. Do not use any cleansing agents that are aggressive on plastics.

Specifications are subject to change without notice! If you have questions, please contact the manufacturer.

## **FR** Notice importante AQFPRO PC!

Les agents chimiques, en contact direct avec le luminaire ou sous forme de particules en suspension dans l'air, de même que les méthodes de nettoyage inadéquates peuvent entraîner une détérioration du luminaire !  
Ne pas utiliser de solutions à moyenne ou forte teneur en alcalins ou en acides, ni de solvants ou produits de nettoyage susceptibles d'attaquer les matières plastiques.

Sous réserve de modifications des spécifications techniques! Pour toute question, contactez le fabricant.

## **IT** Nota sul materiale AQFPRO PC!

Gli agenti chimici, a contatto diretto oppure in sostanze sospese nell'atmosfera, possono danneggiare gli apparecchi di illuminazione. Ugualmente dannoso può risultare un inadeguato utilizzo di prodotti per la pulizia quali concentrati alcalinici, soluzioni acide o altri solventi.  
Non utilizzare alcun prodotto che sia aggressivo sulla plastica.

Modifiche tecniche sono soggette a cambiamenti senza preavviso!  
Se avete domande, si prega di contattare il produttore.

## **NL** Materiaal Aanwijzingen AQFPRO PC!

Chemische invloeden, hetzij door direct contact, hetzij door stoffen die in de atmosfeer rondzweven of niet geschikte reinigingsmethodes, kunnen het armatuur schade toedienen.  
Gebruik geen matige tot sterk loog- en zuurhoudende stoffen en geen oplossings- of reinigingsmiddelen die de kunststof aantasten.

Technische wijzigingen voorbehouden! Als u vragen hebt, kunt u contact opnemen met de fabrikant.



**Distance  
1280 mm**

**The luminaire should be positioned  
so that prolonged staring into  
the luminaire at a distance closer  
than 1280 mm is not expected.**



[www.thornlighting.com/AQUP](http://www.thornlighting.com/AQUP)



## **(DE)** Hinweise für die Montage und den Betrieb!

Die Montage und Inbetriebnahme der Leuchte sowie jede Veränderung an der Leuchte darf nur von autorisierten Fachkräften (qualifizierter Elektriker) durchgeführt werden. Die nationalen Errichterbestimmungen sind zu beachten. Vor jeder Arbeit an der Leuchte ist diese vom Netz zu trennen. **Hot Plug-in ist nicht möglich und kann zu Schäden an der Leuchte führen!** Der Hersteller haftet nicht für Schäden, die aus fehlerhafter Montage, aus unsachgemäßem Betrieb oder unautorisierten Veränderungen an der Leuchte resultieren. Die Lichtquelle dieser Leuchte darf nur vom



Hersteller oder einem von ihm beauftragten Servicetechniker oder einer vergleichbar qualifizierten Person ausgetauscht werden. **Vorsicht, Gefahr eines elektrischen Schlags!**

Technische Änderungen vorbehalten! Bei Fragen wenden sie sich an den Hersteller.

## **(EN)** Instructions for installation and operation!

The installation and commissioning of the luminaire as well as any modification to the luminaire may only be performed by authorized personnel (qualified electrician). National installation regulations must be observed. Before any work on the appliance is done, it must be disconnected from mains. **Hot plug-in is not an option and may cause damage to the lamp or luminaire!** The manufacturer is not liable for damages resulting from improper or faulty installation or operation or from unauthorized modifications to the luminaire. The light source contained in this luminaire shall only be replaced by the manufacturer or his service agent or a similarly qualified person.



**Caution, risk of electric shock!**

Specifications are subject to change without notice! If you have questions, please contact the manufacturer.

## **(FR)** Instructions pour l'installation et l'utilisation!

L'installation et la mise en service du luminaire ainsi que toute modification au luminaire doivent être effectuées par un personnel autorisé (électricien qualifié). Les règles nationales d'installation doivent être respectées. Avant toute intervention sur l'appareil, il doit être débranché de son alimentation. **Le branchement à chaud est interdit, et peut endommager à la lampe ou le luminaire!** Le fabricant décline toute responsabilité pour les dommages résultant d'une mauvaise installation ou opération, ou d'une modification non autorisée du luminaire. La source lumineuse présente dans le luminaire ne peut être remplacée que par le fabricant, par son service technique ou une personne qualifiée. **Avertissement, risque de choc électrique.**



Sous réserve de modifications des spécifications techniques! Pour toute question, contactez le fabricant.

## **(IT)** Istruzioni per l'installazione e il funzionamento!

L'installazione e la messa in servizio degli apparecchi, nonché qualsiasi modifica dell'apparecchio può essere eseguita solo da personale autorizzato (elettricista qualificato). Le norme nazionali di installazione devono essere rispettate. Prima di qualsiasi intervento sull'apparecchio, questo deve essere scollegato dalla rete. **Non è possibile un Hot Plug In e può causare danni alla lampada o all'apparecchio!** Il produttore non si assume alcuna responsabilità per i danni derivanti da un'installazione impropria o difettosa, o per modifiche non autorizzate apportate all'apparecchio. La sorgente



luminosa contenuta in questo apparecchio può essere sostituita solo dal produttore o da un centro assistenza autorizzato o da una persona qualificata. **Attenzione, rischio di folgorazione!** Modifiche tecniche sono soggette a cambiamenti senza preavviso! Se avete domande, si prega di contattare il produttore.

## **(NL)** Aanwijzingen voor installatie en bediening!

De installatie en inbedrijfstelling van het armatuur, alsook elke wijziging in of aan het armatuur mogen alleen door bevoegd personeel (elektricien) worden uitgevoerd. De nationale installatie voorschriften moeten worden nageleefd. Voor alle werkzaamheden aan het apparaat, moet deze worden losgekoppeld van het net. **Hot plug-in is niet mogelijk en kan schade aan de lichtbron of het verlichtingstoestel veroorzaken!** De fabrikant is niet aansprakelijk voor schade als gevolg van onjuiste of foutieve installatie, bediening of schade welke het gevolg zijn van niet geautoriseerde wijzigingen aan het armatuur. De lichtbron in dit armatuur mag enkel door de fabrikant, een service agent of een gelijkwaardig gekwalificeerd persoon vervangen worden. **WAARSCHUWING: Gevaar voor elektrische schokken.** Technische wijzigingen voorbehouden! Als u vragen hebt, kunt u contact opnemen met de fabrikant.



## **i** Info on (non-) replaceability:

