

UK Installation instructions

FI Asennusohje

LV Instalācijas instrukcija

DE Montageanleitung

FR Notice de montage

NO Monteringsanvisning

CZ Montážní návod

HU Szerelési útmutató

PL Instrukcja montażu

DK Monteringsvejledning

IT Istruzioni di montaggio

SE Installationsanvisning

EE Paigaldusjuhend

LT Montavimo Instrukcijos

RU ИНСТРУКЦИЯ ПО МОНТАЖУ

TYPE : CONTRAST 3 36/52L LARGE

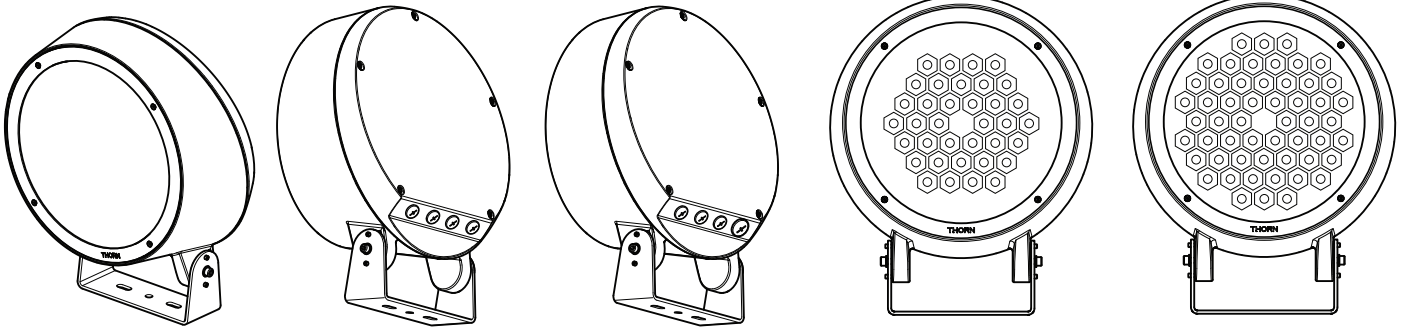

CONTRAST 3
36 LEDS

CONTRAST 3
52 LEDS

The luminaire with clear optic should be positioned so that prolonged staring into the luminaire at a distance <2m is not expected

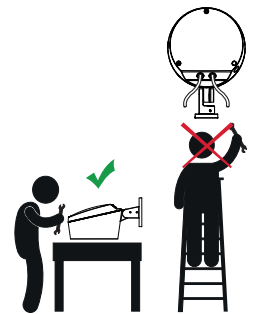
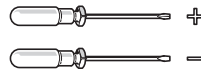
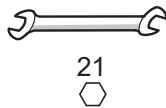

CLASS II

IP66

IK08

CE

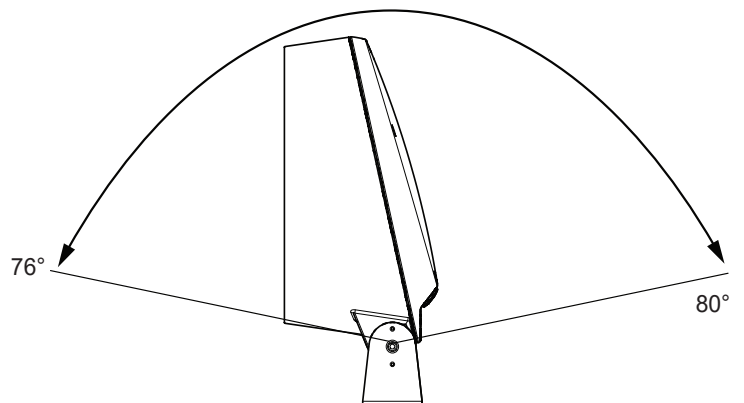
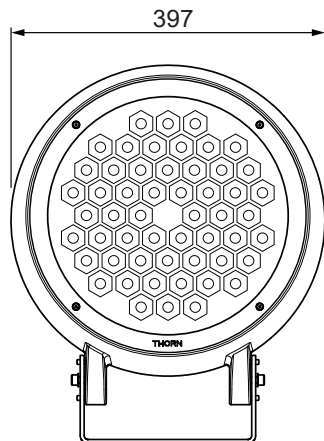
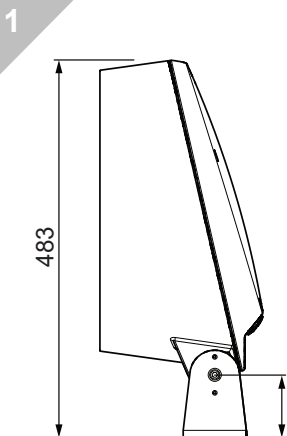

		36L	52L
(kg)	W	13	13,2
(kg)	BW	13	13,2
(kg)	RGBW	12,4	12,6

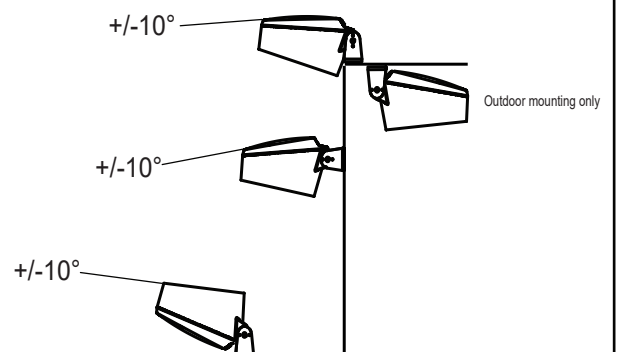
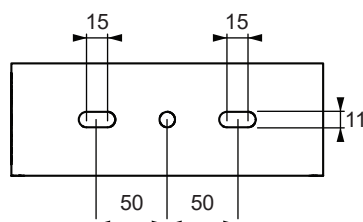

2

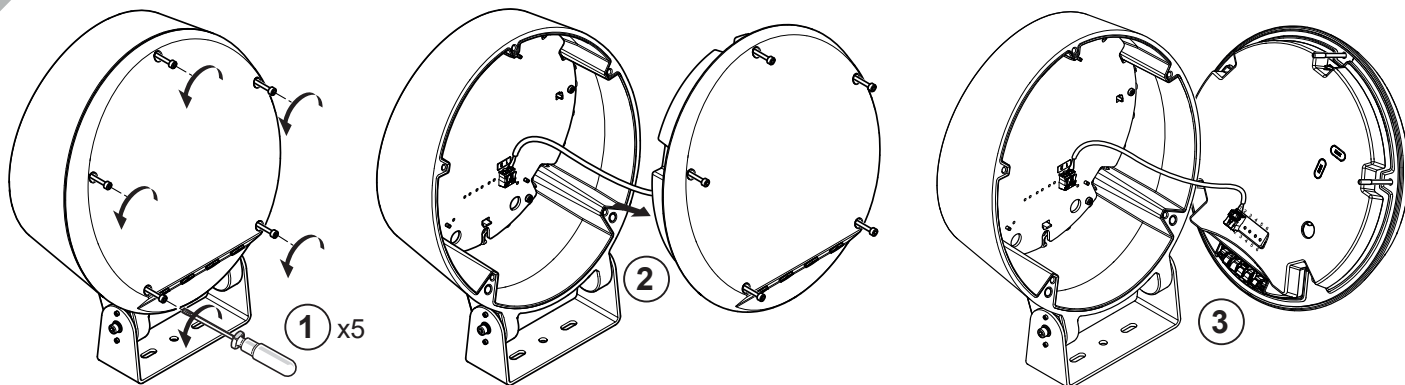

3

CONTRAST 3 36/52L HFX

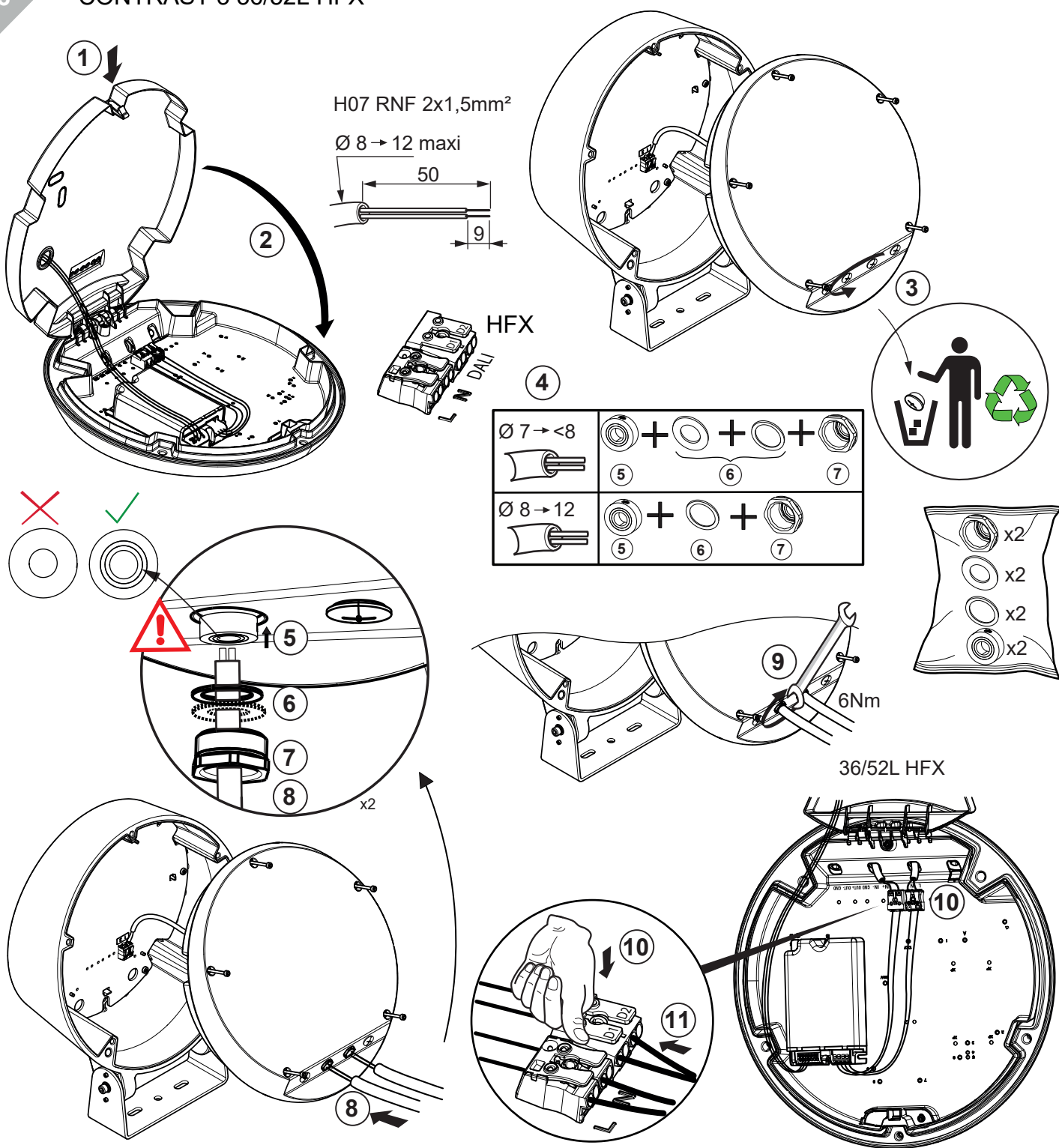

CONTRAST 36/52L BC WIRELESS BLUETOOTH

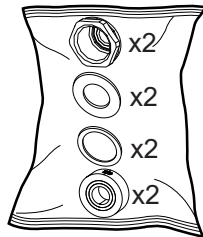
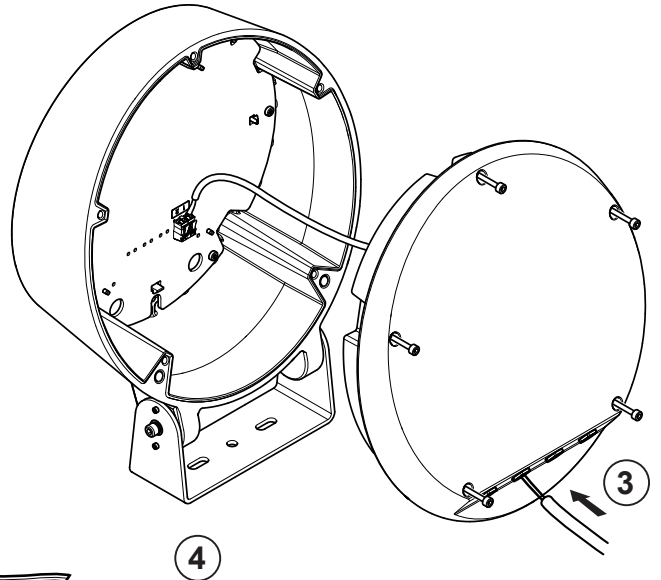
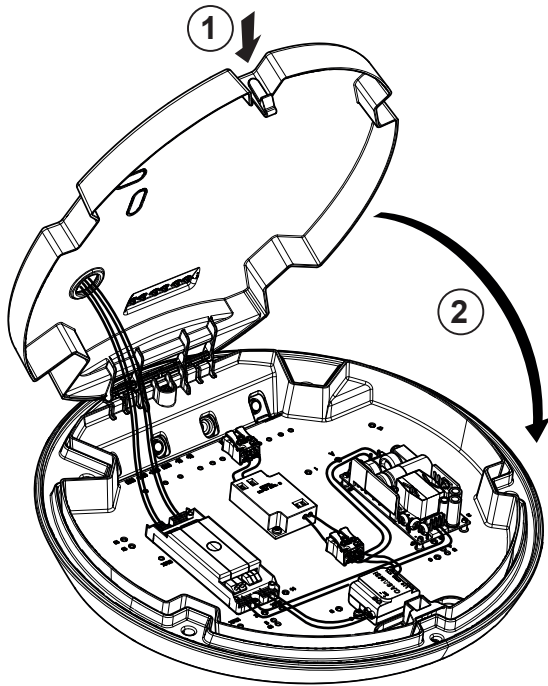

Ø 7 → <8		+		+		+	
	5		6		7		7
Ø 8 → 12		+		+		+	
	5		6		7		7

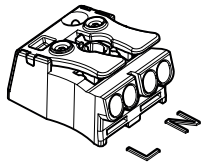
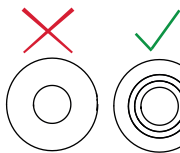

H07 RNF 2x1,5mm²

Ø 8 → 12 maxi

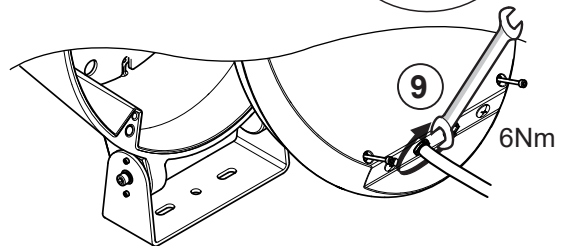
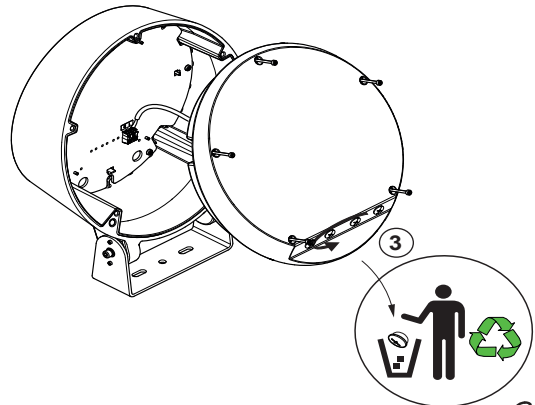
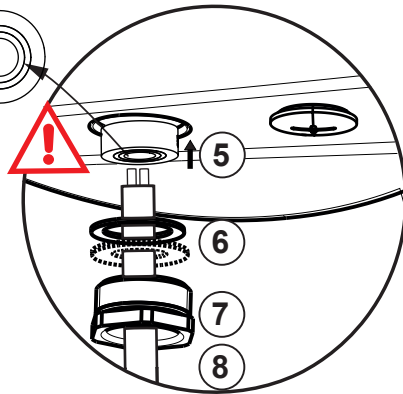

CONTRAST 36/52L RGBW BC

CONTRAST 36/52L W BC

CONTRAST 36/52L BW BC

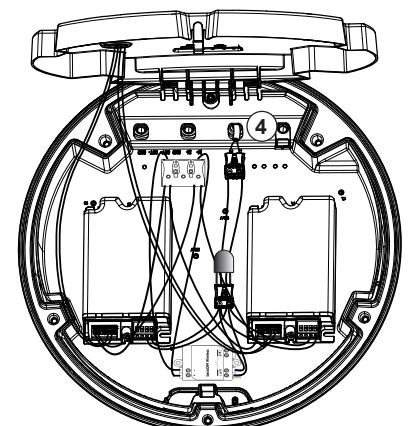
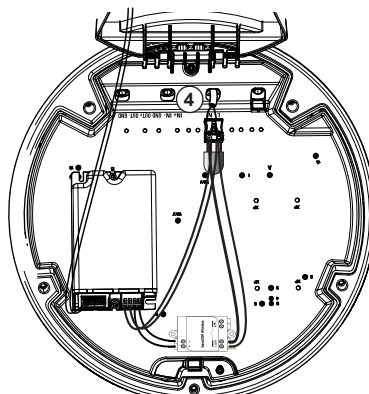
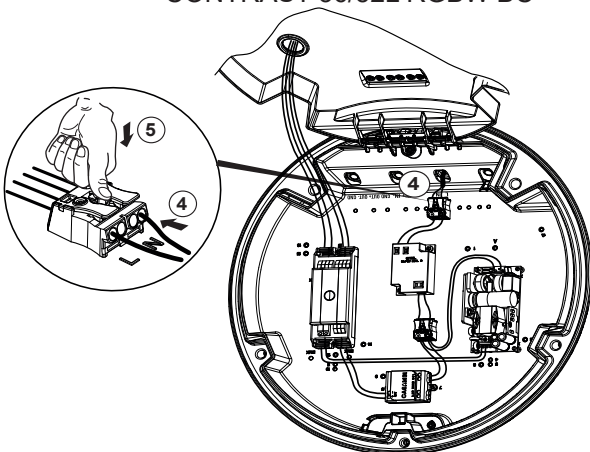

5 INFO CONTRAST BC

i APP store



4 Remote BT



i Documentation



EN



DE



www.tridonic.com/basicdim-wireless



Do not connect DALI!

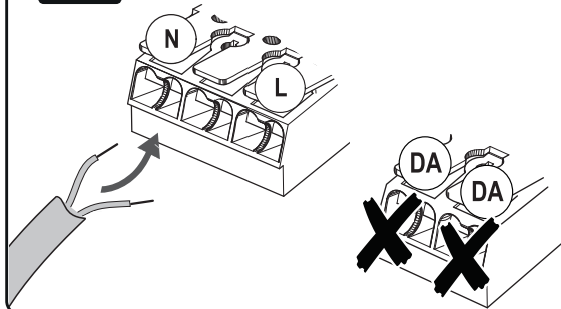

EN:



Only one to one connection.
No mesh communication
between luminaires

In the app, go to

Network setup
-> Control options :

Select « Remember last
state »

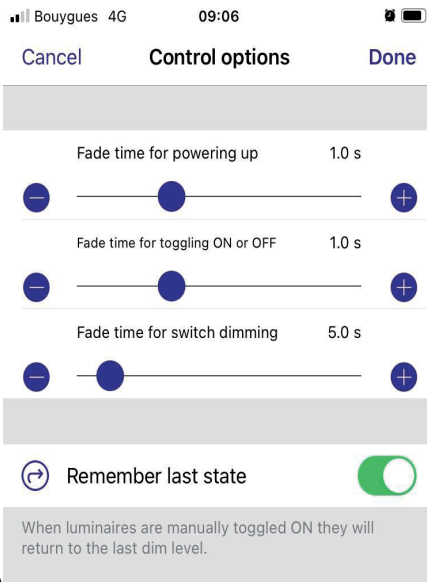

FR :



Pas de communication entre
luminaires (pas de mesh)

Dans l'appli, allez dans

Configuration du reseau
-> Options de contrôle :

Sélectionnez « Mémoriser le
dernier état »



DE :



Nur direkte Eins-zu-Eins
Beziehung,
keine Mesh-Kommunikation
zwischen den Leuchten

In der App ,

Netzwerkkonfiguration
-> Steuerungsoptionen :

Selektieren « Letzen Zustand
merken »

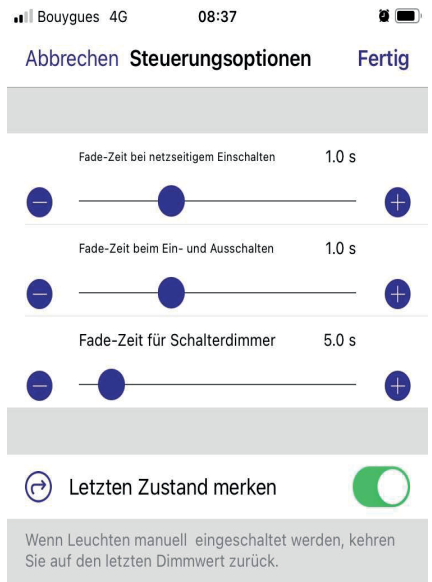

i Installation of fittings

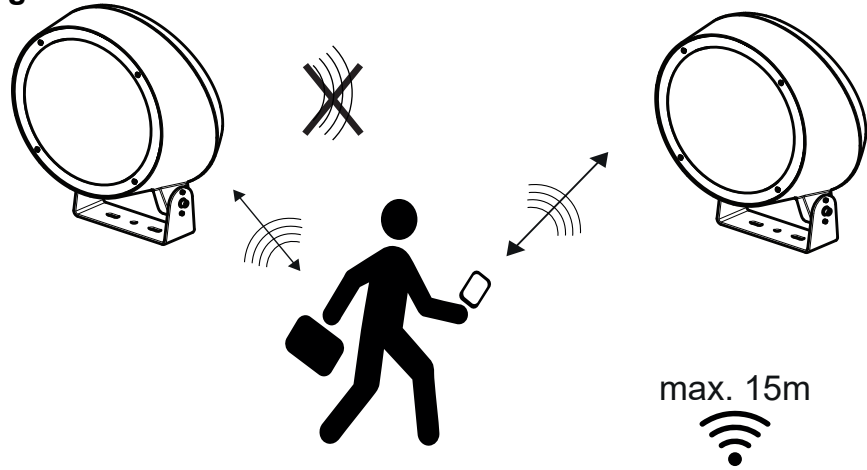

NO MESH (SINGLE CONNECTION ONLY), 1 LUMINAIRE ONLY PER NETWORK

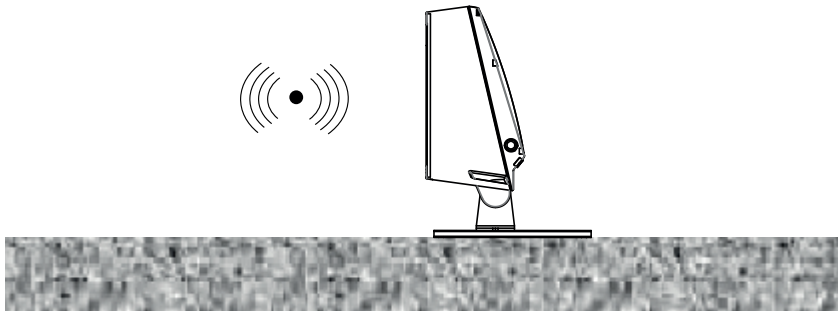
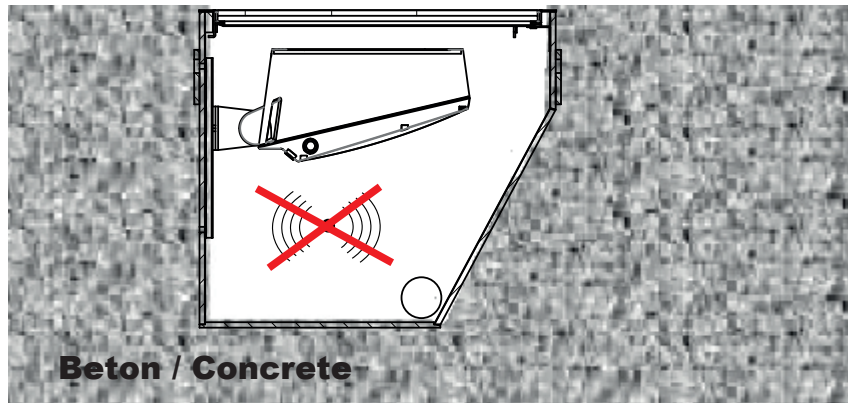

H07 RNF 2x1,5mm²

Ø 8 → 12 maxi

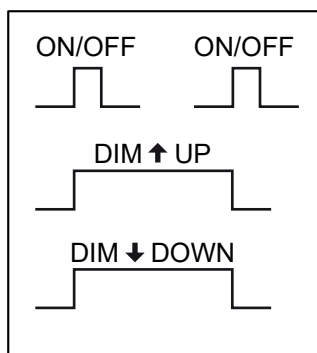
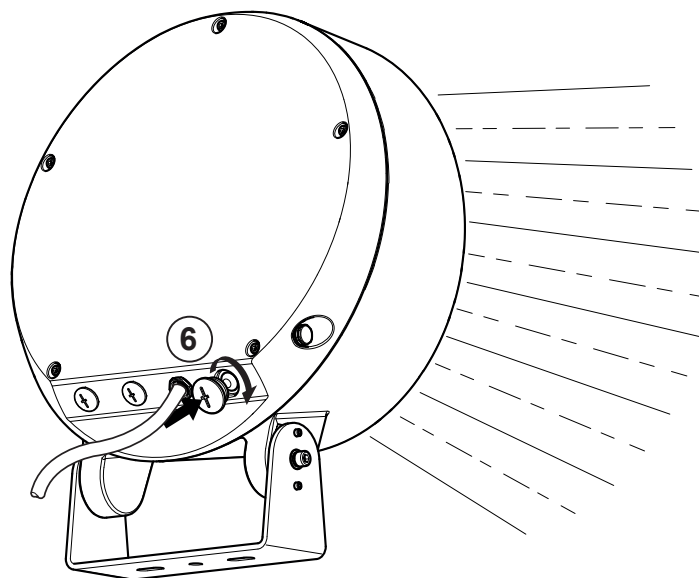
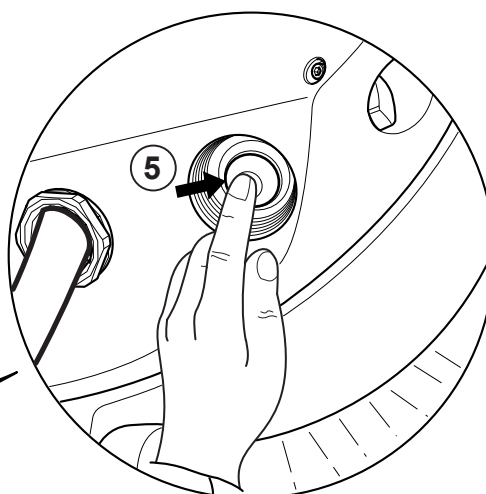
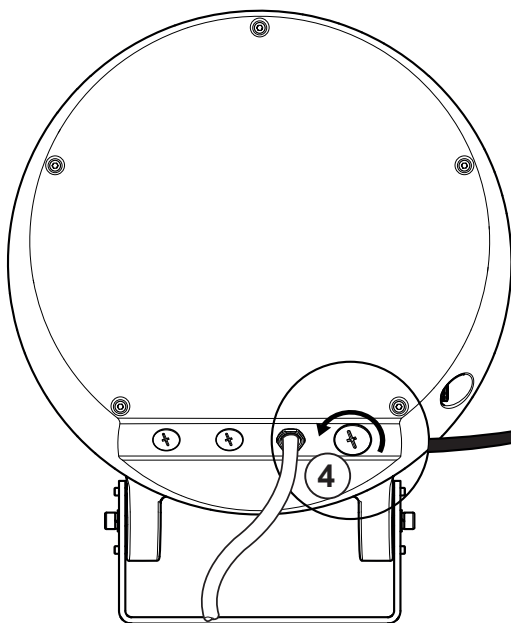
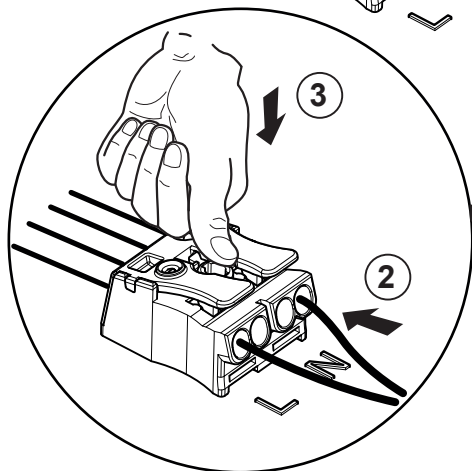
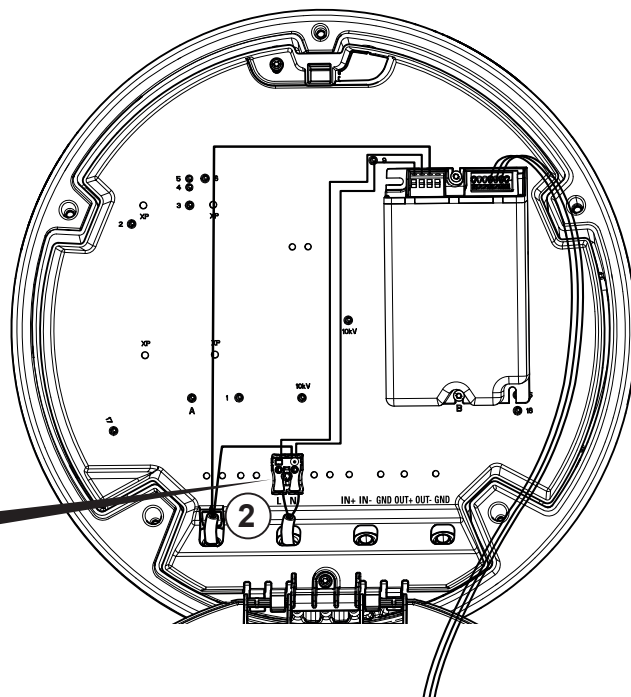
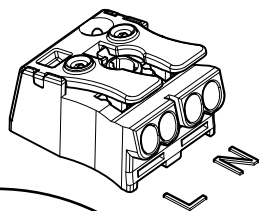
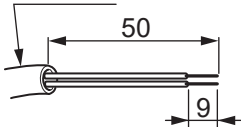

H07 RNF 2x1,5mm²

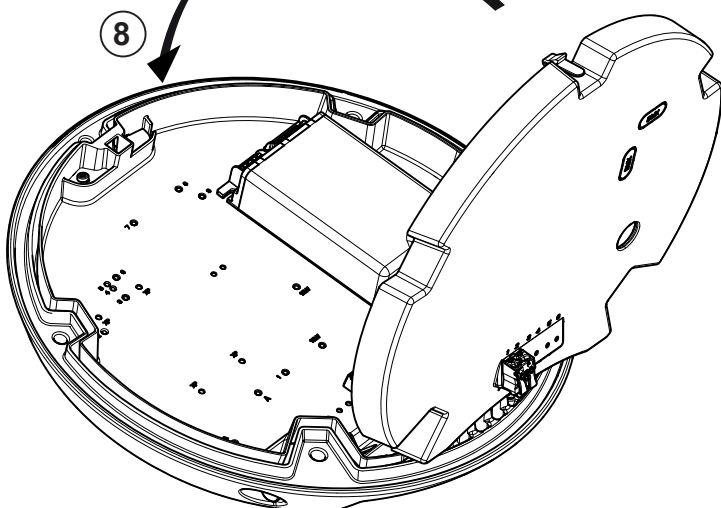
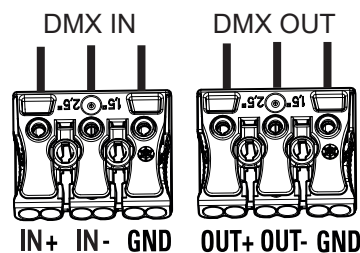
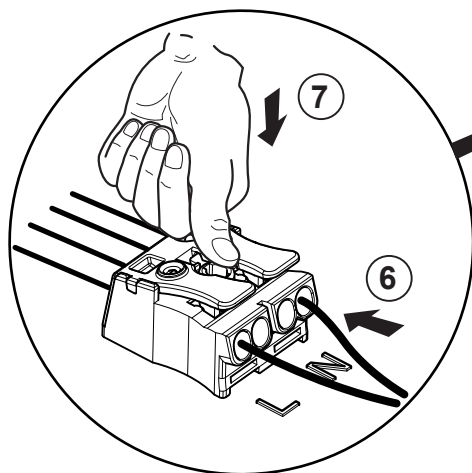
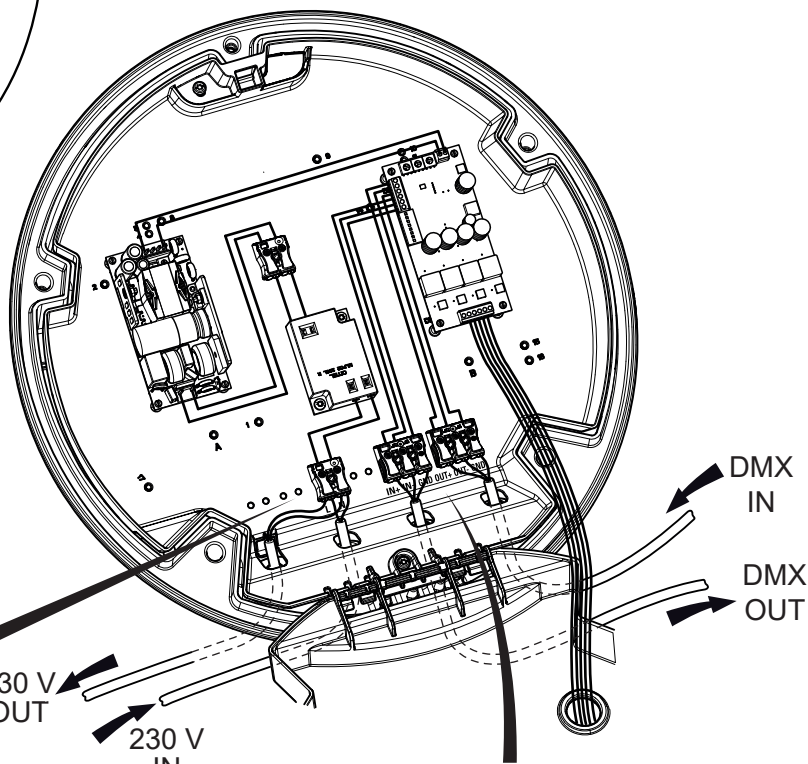
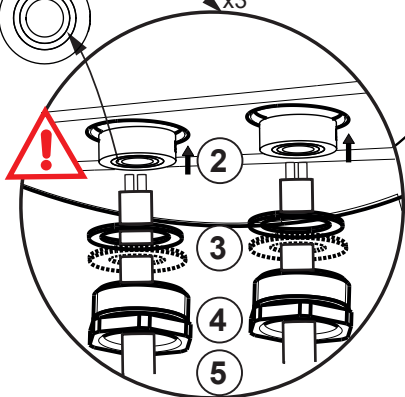
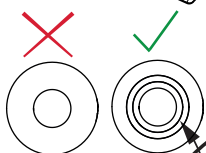
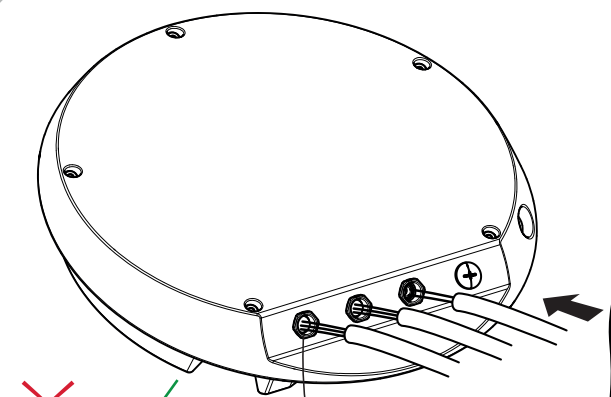
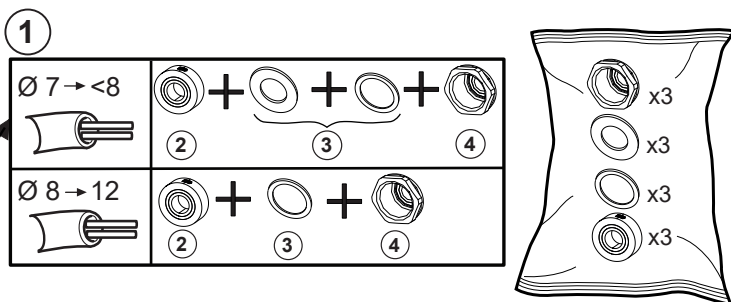

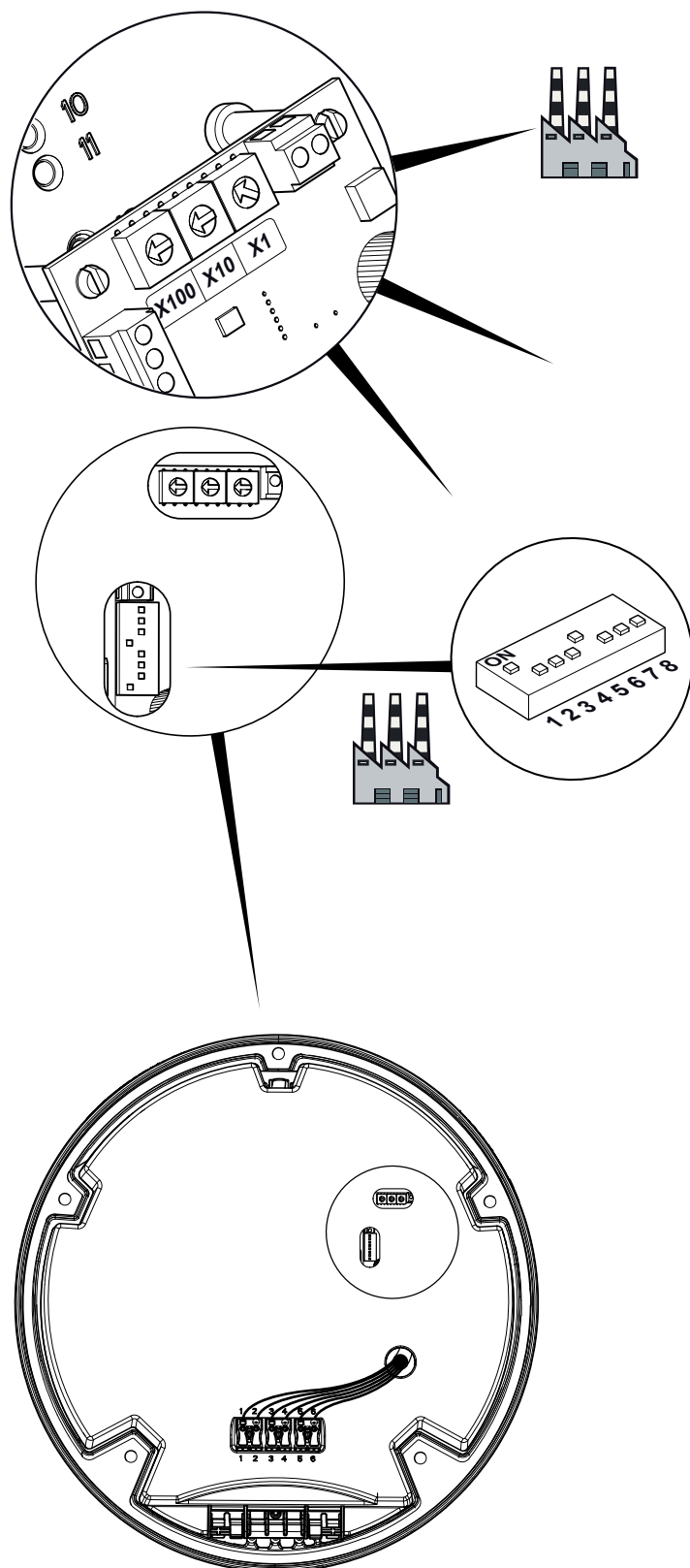

	100	10	1																																				
Address	<table border="1" style="width: 100%; height: 100%;"> <tr><td>1</td><td>2</td><td>3</td><td>4</td></tr> <tr><td>0</td><td>←</td><td></td><td>5</td></tr> <tr><td>9</td><td>8</td><td>7</td><td>6</td></tr> </table>	1	2	3	4	0	←		5	9	8	7	6	<table border="1" style="width: 100%; height: 100%;"> <tr><td>1</td><td>2</td><td>3</td><td>4</td></tr> <tr><td>0</td><td>←</td><td></td><td>5</td></tr> <tr><td>9</td><td>8</td><td>7</td><td>6</td></tr> </table>	1	2	3	4	0	←		5	9	8	7	6	<table border="1" style="width: 100%; height: 100%;"> <tr><td>1</td><td>2</td><td>3</td><td>4</td></tr> <tr><td>0</td><td>↘</td><td></td><td>5</td></tr> <tr><td>9</td><td>8</td><td>7</td><td>6</td></tr> </table>	1	2	3	4	0	↘		5	9	8	7	6
1	2	3	4																																				
0	←		5																																				
9	8	7	6																																				
1	2	3	4																																				
0	←		5																																				
9	8	7	6																																				
1	2	3	4																																				
0	↘		5																																				
9	8	7	6																																				
001																																							

rotary switch setting (address)	Operating mode
1-511	DMX control mode
512-609	default mode
610-699	demonstration mode
670-999	default mode

DMX ADDRESS EXAMPLE

	100	10	1																																				
Address	<table border="1" style="width: 100%; height: 100%;"> <tr><td>1</td><td>2</td><td>3</td><td>4</td></tr> <tr><td>0</td><td>←</td><td></td><td>5</td></tr> <tr><td>9</td><td>8</td><td>7</td><td>6</td></tr> </table>	1	2	3	4	0	←		5	9	8	7	6	<table border="1" style="width: 100%; height: 100%;"> <tr><td>1</td><td>2</td><td>3</td><td>4</td></tr> <tr><td>0</td><td>←</td><td></td><td>5</td></tr> <tr><td>9</td><td>8</td><td>7</td><td>6</td></tr> </table>	1	2	3	4	0	←		5	9	8	7	6	<table border="1" style="width: 100%; height: 100%;"> <tr><td>1</td><td>2</td><td>3</td><td>4</td></tr> <tr><td>0</td><td>←</td><td></td><td>5</td></tr> <tr><td>9</td><td>8</td><td>7</td><td>6</td></tr> </table>	1	2	3	4	0	←		5	9	8	7	6
1	2	3	4																																				
0	←		5																																				
9	8	7	6																																				
1	2	3	4																																				
0	←		5																																				
9	8	7	6																																				
1	2	3	4																																				
0	←		5																																				
9	8	7	6																																				
059	<table border="1" style="width: 100%; height: 100%;"> <tr><td>1</td><td>2</td><td>3</td><td>4</td></tr> <tr><td>0</td><td>←</td><td></td><td>5</td></tr> <tr><td>9</td><td>8</td><td>7</td><td>6</td></tr> </table>	1	2	3	4	0	←		5	9	8	7	6	<table border="1" style="width: 100%; height: 100%;"> <tr><td>1</td><td>2</td><td>3</td><td>4</td></tr> <tr><td>0</td><td>→</td><td></td><td>5</td></tr> <tr><td>9</td><td>8</td><td>7</td><td>6</td></tr> </table>	1	2	3	4	0	→		5	9	8	7	6	<table border="1" style="width: 100%; height: 100%;"> <tr><td>1</td><td>2</td><td>3</td><td>4</td></tr> <tr><td>0</td><td>↗</td><td></td><td>5</td></tr> <tr><td>9</td><td>8</td><td>7</td><td>6</td></tr> </table>	1	2	3	4	0	↗		5	9	8	7	6
1	2	3	4																																				
0	←		5																																				
9	8	7	6																																				
1	2	3	4																																				
0	→		5																																				
9	8	7	6																																				
1	2	3	4																																				
0	↗		5																																				
9	8	7	6																																				
099	<table border="1" style="width: 100%; height: 100%;"> <tr><td>1</td><td>2</td><td>3</td><td>4</td></tr> <tr><td>0</td><td>←</td><td></td><td>5</td></tr> <tr><td>9</td><td>8</td><td>7</td><td>6</td></tr> </table>	1	2	3	4	0	←		5	9	8	7	6	<table border="1" style="width: 100%; height: 100%;"> <tr><td>1</td><td>2</td><td>3</td><td>4</td></tr> <tr><td>0</td><td>↗</td><td></td><td>5</td></tr> <tr><td>9</td><td>8</td><td>7</td><td>6</td></tr> </table>	1	2	3	4	0	↗		5	9	8	7	6	<table border="1" style="width: 100%; height: 100%;"> <tr><td>1</td><td>2</td><td>3</td><td>4</td></tr> <tr><td>0</td><td>↘</td><td></td><td>5</td></tr> <tr><td>9</td><td>8</td><td>7</td><td>6</td></tr> </table>	1	2	3	4	0	↘		5	9	8	7	6
1	2	3	4																																				
0	←		5																																				
9	8	7	6																																				
1	2	3	4																																				
0	↗		5																																				
9	8	7	6																																				
1	2	3	4																																				
0	↘		5																																				
9	8	7	6																																				
126	<table border="1" style="width: 100%; height: 100%;"> <tr><td>1</td><td>2</td><td>3</td><td>4</td></tr> <tr><td>0</td><td>↗</td><td></td><td>5</td></tr> <tr><td>9</td><td>8</td><td>7</td><td>6</td></tr> </table>	1	2	3	4	0	↗		5	9	8	7	6	<table border="1" style="width: 100%; height: 100%;"> <tr><td>1</td><td>2</td><td>3</td><td>4</td></tr> <tr><td>0</td><td>↗</td><td></td><td>5</td></tr> <tr><td>9</td><td>8</td><td>7</td><td>6</td></tr> </table>	1	2	3	4	0	↗		5	9	8	7	6	<table border="1" style="width: 100%; height: 100%;"> <tr><td>1</td><td>2</td><td>3</td><td>4</td></tr> <tr><td>0</td><td>↘</td><td></td><td>5</td></tr> <tr><td>9</td><td>8</td><td>7</td><td>6</td></tr> </table>	1	2	3	4	0	↘		5	9	8	7	6
1	2	3	4																																				
0	↗		5																																				
9	8	7	6																																				
1	2	3	4																																				
0	↗		5																																				
9	8	7	6																																				
1	2	3	4																																				
0	↘		5																																				
9	8	7	6																																				
154	<table border="1" style="width: 100%; height: 100%;"> <tr><td>1</td><td>2</td><td>3</td><td>4</td></tr> <tr><td>0</td><td>↗</td><td></td><td>5</td></tr> <tr><td>9</td><td>8</td><td>7</td><td>6</td></tr> </table>	1	2	3	4	0	↗		5	9	8	7	6	<table border="1" style="width: 100%; height: 100%;"> <tr><td>1</td><td>2</td><td>3</td><td>4</td></tr> <tr><td>0</td><td>←</td><td></td><td>5</td></tr> <tr><td>9</td><td>8</td><td>7</td><td>6</td></tr> </table>	1	2	3	4	0	←		5	9	8	7	6	<table border="1" style="width: 100%; height: 100%;"> <tr><td>1</td><td>2</td><td>3</td><td>4</td></tr> <tr><td>0</td><td>↗</td><td></td><td>5</td></tr> <tr><td>9</td><td>8</td><td>7</td><td>6</td></tr> </table>	1	2	3	4	0	↗		5	9	8	7	6
1	2	3	4																																				
0	↗		5																																				
9	8	7	6																																				
1	2	3	4																																				
0	←		5																																				
9	8	7	6																																				
1	2	3	4																																				
0	↗		5																																				
9	8	7	6																																				

DIP-switch #	Operating mode
1	DMX IN line termination resistor on/off

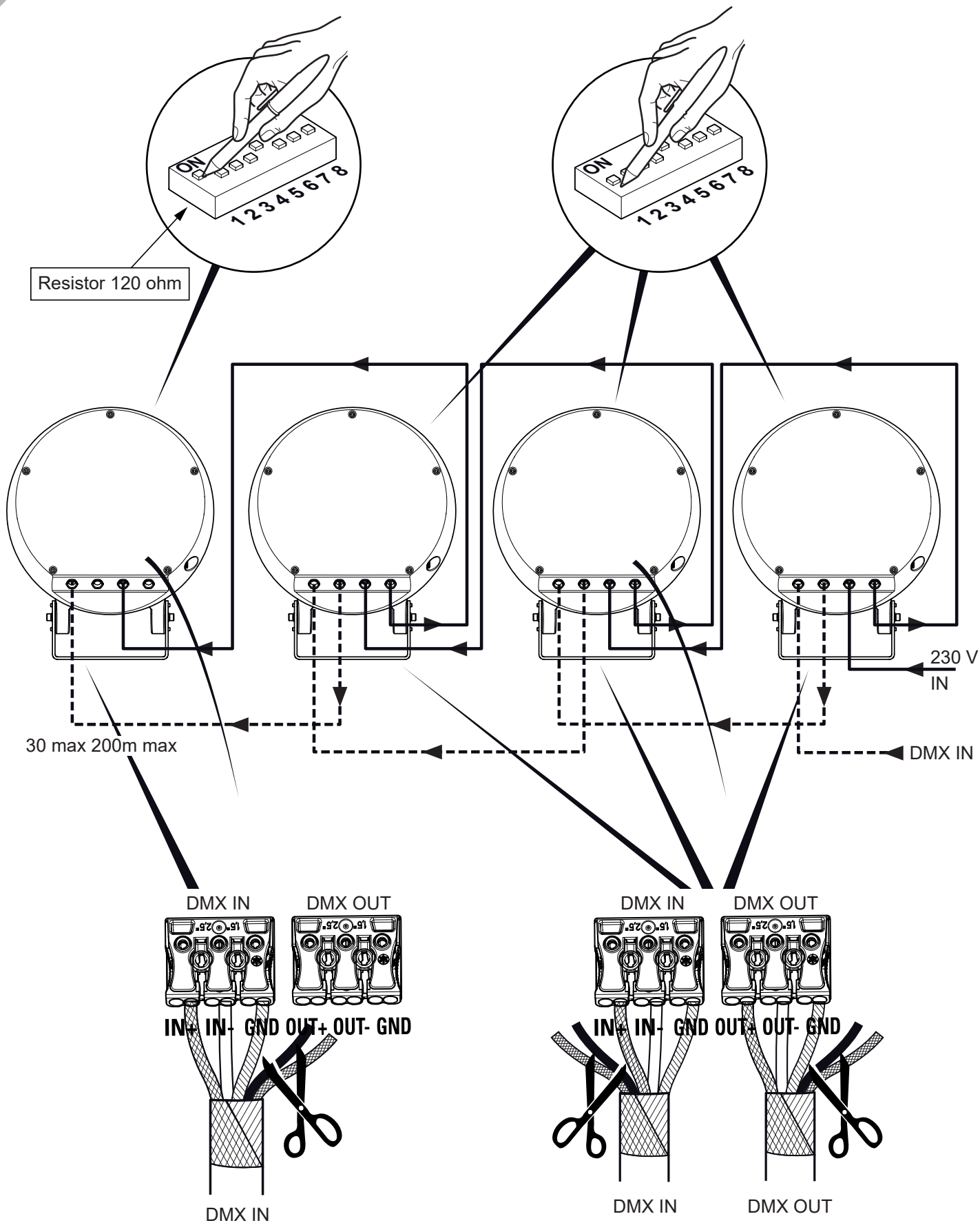

DMX 512 Cable
Ref. 96261601

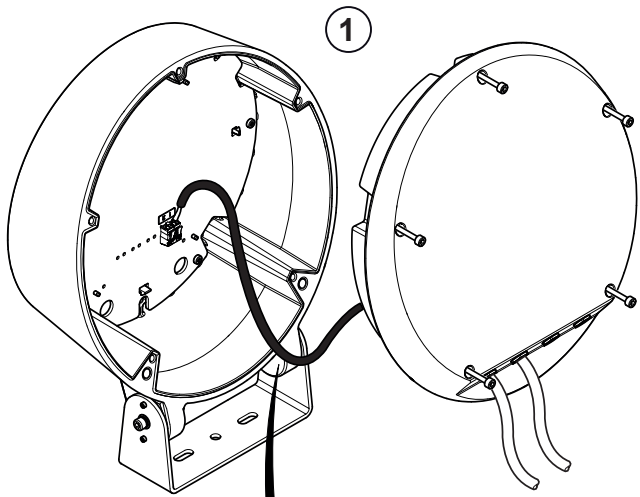

Wiring shall not be twisted

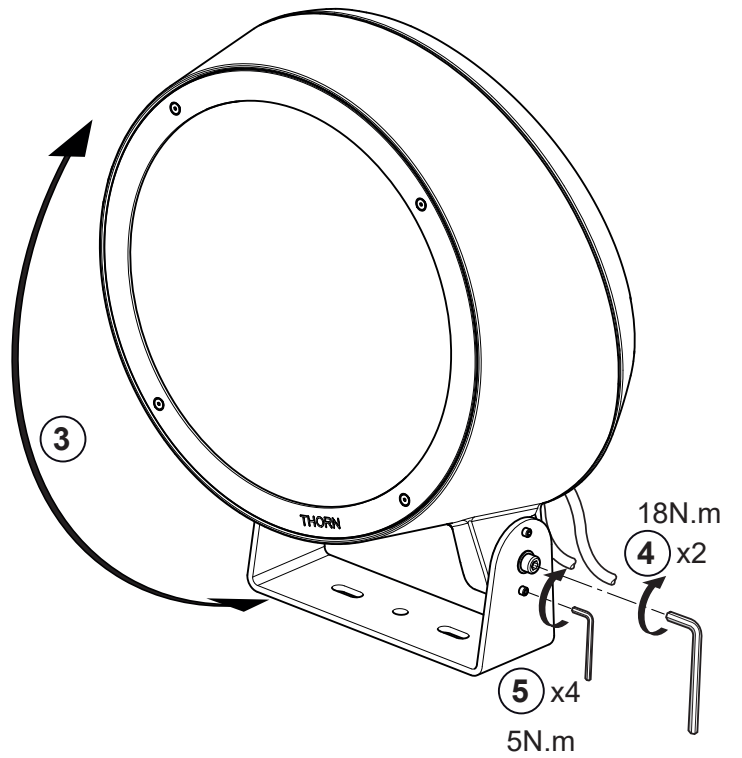
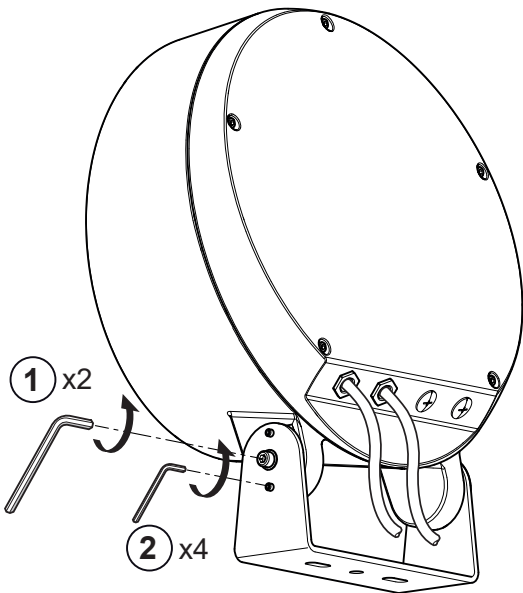
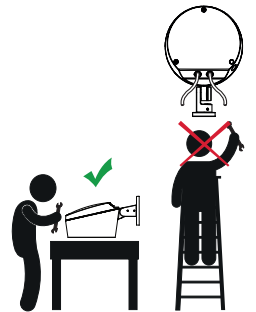
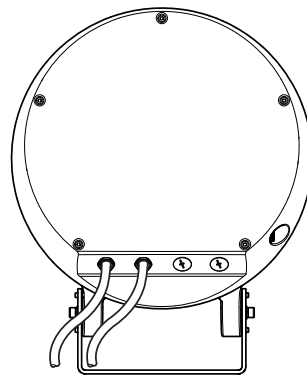
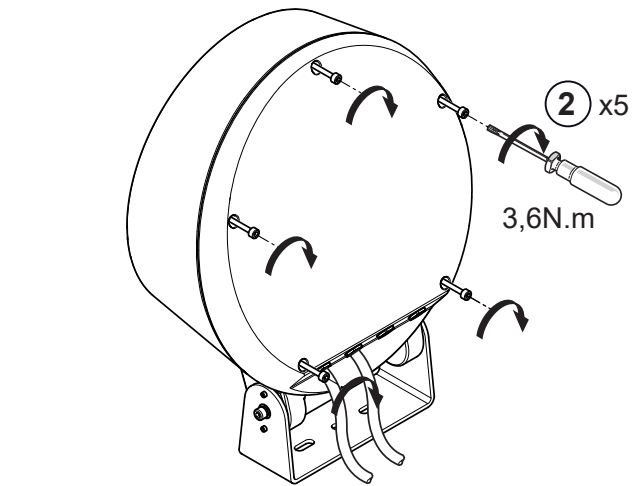

FRANCAIS

-Remplacer toute protection fissurée.
-Les luminaires classe II doivent être installés de façon à ce que la partie métallique ne soit pas en contact avec l'installation électrique connectée à la terre.

ATTENTION: Les luminaires classe I doivent être reliés à la terre.

-Ce luminaire fonctionne à une tension nominale qui doit être coupée avant toute intervention sur l'appareillage.
-Toute modification de cet appareil est interdite.
-Respecter la distance minimale par rapport aux objets éclairés définie par ce sigle.

SVERIGE

-Ersätta alla spräckta skyddsplåtar.
-Klass II armaturer måste installeras så att nakna metalldelar i armaturen inte är i kontakt med någon elektrisk installation, kopplad till en skyddledare.

WARNING: Klass I armaturer måste vara jordade.

-Denna armatur fungerar med högspänning som måste vara fränslagen före ingripande i driftdonen.
-Alla ändringar i denna armatur är förbjuden.

ITALIANO

-Sostituire sempre tutte le protezioni danneggiate.
-Gli apparecchi in classe II devono essere installati in modo che le parti metalliche non siano in contatto con apparati elettrici collegati a terra.

ATTENZIONE: Gli apparecchi in class I devono essere collegati a terra.

-Questo apparecchio funziona a tensione nominale, questa deve essere interrotta prima di ogni intervento sul gruppo di alimentazione.
-Ogni modifica dell' apparecchio è proibita.

ENGLISH

-Replace any cracked protective shield.
-Class II luminaires must be installed so that exposed metal work of the luminaire is not in contact with any part of the electrical installation connected to a protective conductor.

WARNING: Class I luminaires must be earthed.

-This luminaire operates at mains voltage which must be switched off before intervention in control gear.
-Any modification to this luminaire is forbidden.
-Lighted objects nearer than the minimal distance in the is forbidden.

DEUTSCH

-Ersetze jede gebrochene Schutzscheibe.
-Schutzklasse II Leuchten müssen so installiert werden, daß berührbare Metallteile nicht mit einem, an dem Schutzleiter angeschlossenen Teil der elektrischen Installation in Kontakt kommen können.

ACHTUNG: Schutzklasse I Leuchten müssen geerdet sein.

-Diese Leuchte wird mit Netzspannung betrieben. Bevor Eingriffe am Vorschaltgerät vorgenommen werden sowie vor Wartung und Installation, ist die Versorgungsspannung abzuschalten.
-Jede Änderung an dieser Leuchte ist verboten.

SUOMI

-Rikkoontunut suojalasi vaihdettava välittömästi uuden vastaavaan.
-Asennettaessa suojausluokan II valaisinta on peruseristetyin johdon ja kosketeltavien metalliosien välinen kosketus tehokkaasti eristettävä.

VAROITUS: Suojausluokan I valaisin täytyy maadoittaa.

-Verkköjännite on kytkettävä pois ennen valaisimen huoltotoimenpiteitä.
-Valaisimen rakennetta ei saa muuttaa.