

# JAMIE 201.930.55.2



## Beschreibung

- flexibler Mini-Stromschienenstrahler in kompakter Bauform mit zylinderförmigem Design
- Leuchte 350° drehbar und 90° schwenkbar über integrierten Gelenkarm
- hohe Wartungsfreundlichkeit
- keine UV- und Wärmestrahlung
- Wärmemanagement über Gehäuse
- Hightech-Reflektorlinse aus PMMA für maximale Lichtausbeute und optimale Entblendung
- Gehäusezylinder aus Aluminium
- 3-Phasen-Stromschienenadapter
- Betriebsgerät (LED-Konverter) integriert

## Standardoptionen



## Sonderoptionen



Farbe	Artikelnummer	EAN
schwarz	657917	4043544668356
silber	657918	4043544668363
weiß	657919	4043544668370

## Lichttechnik / Normen

Leuchtmittel	LED Spot / CRI 90 / 3000 K
EPREL Lichtquellen	854624
Lebensdauer	L90 B50 50.000 h L80 B50 100.000 h L80 B20 50.000 h
Systemleistung	12.0 W
Leuchten-Lichtstrom	680 lm
Systemeffizienz	56.66 lm/W
Moduleffizienz	133.73 lm/W
UGR Klasse	≤28
Abstrahlwinkel	55°
Versorgungsspannung	220 - 240 V / 50 - 60 Hz
Schutzklasse	II
Schutzart	IP20

## Abmessungen / Gewichte

Länge	94 mm
Breite	48 mm
Höhe	168 mm
Durchmesser Lichtkopf	48 mm
Nettogewicht	0.30 kg
Bruttogewicht	0.40 kg

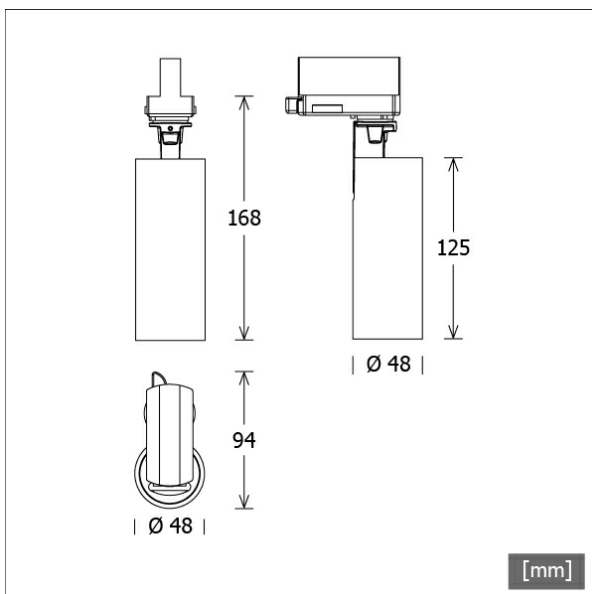

# JAMIE 201.930.55.2

Jamie 200 (1xLED 12W 930/3000K 680lm 55 °)

— C0/C180 cd / 1000 lm

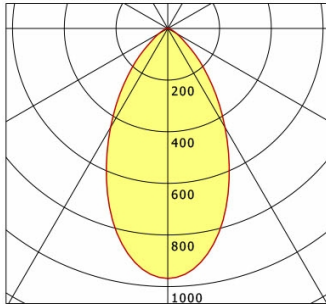

	C0	C90	C180	C270
0°	969	969	969	969
15°	795	795	795	795
30°	442	442	442	442
45°	165	165	165	165
60°	40	40	40	40
75°	10	10	10	10
90°	0	0	0	0
cd / 1000 lm				

Offset [m] Cone width [m] Illuminance [lx]

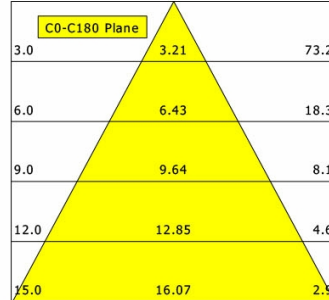

<b>η</b>	LED
Efficiency	57 lm/W
Direct/Indirect	↓ 100% / ↑ 0%
System Power	12 W
<b>UGR</b>	X=4H, Y=8H
Reflection factors	70/50/20
UGR C0/C180	26.6
UGR C90/C270	26.6
CIE Flux Codes	80 96 99 100 100
Ra/CRI	>90

LTS

## Zubehör



**EU 10**  
Anbau-Stromschiene Professional  
(Länge: 1000 mm)



**EU 20**  
Anbau-Stromschiene Professional  
(Länge: 2000 mm)



**EU 21**  
Anbau-Stromschiene Professional  
(Länge: 3000 mm)



**EU 22**  
Anbau-Stromschiene Professional  
(Länge: 4000 mm)



**EUE 20**  
Einbau-Stromschiene Professional  
(Länge: 2000 mm)



**EUE 21**  
Einbau-Stromschiene Professional  
(Länge: 3000 mm)



**EUE 22**  
Einbau-Stromschiene Professional  
(Länge: 4000 mm)



**LAB 60**  
3-Phasen-Einbau-Monopoint mit Busoption



**LAB 60 A**  
3-Phasen-Anbau-Monopoint mit Busoption



**ST-A 10/9000A-1-ST**  
Anbau-Stromschiene ONETrack Advance mit Datenbus  
(Länge: 1000 mm)



**ST-A 20/9000A-2-ST**  
Anbau-Stromschiene ONETrack Advance mit Datenbus  
(Länge: 2000 mm)



**ST-A 30/9000A-3-ST**  
Anbau-Stromschiene ONETrack Advance mit Datenbus  
(Länge: 3000 mm)

# JAMIE 201.930.55.2

## Zubehör



**ST-A 40/9000A-4-ST**  
Anbau-Stromschiene ONETrack Advance mit Datenbus  
(Länge: 4000 mm)



**ST-A MONO/9000-BPU-D**  
3-Phasen-Anbau-Monopoint mit Busoption



**ST-E 10/9000-1-R**  
Einbau-Stromschiene ONETrack mit Datenbus  
(Länge: 1000 mm)



**ST-E 20/9000-2-R**  
Einbau-Stromschiene ONETrack mit Datenbus  
(Länge: 2000 mm)



**ST-E 30/9000-3-R**  
Einbau-Stromschiene ONETrack mit Datenbus  
(Länge: 3000 mm)



**ST-E 40/9000-4-R**  
Einbau-Stromschiene ONETrack mit Datenbus  
(Länge: 4000 mm)



**ST-E MONO/9000-BPU-D**  
3-Phasen-Einbau-Monopoint mit Busoption