

**EN** Installation instructions  
**DE** Montageanleitung  
**CS** Montážní návod  
**DK** Monteringsvejledning  
**ET** Paigaldusjuhend

**FI** Asennusohje  
**FR** Notice de montage  
**HU** Szerelési útmutató  
**IT** Istruzioni di montaggio  
**LT** Montavimo Instrukcijos

**LV** Instalācijas instrukcija  
**NO** Monteringsanvisning  
**PL** Instrukcja montażu  
**SV** Installationsanvisning  
**RU** ИНСТРУКЦИЯ ПО МОНТАЖУ

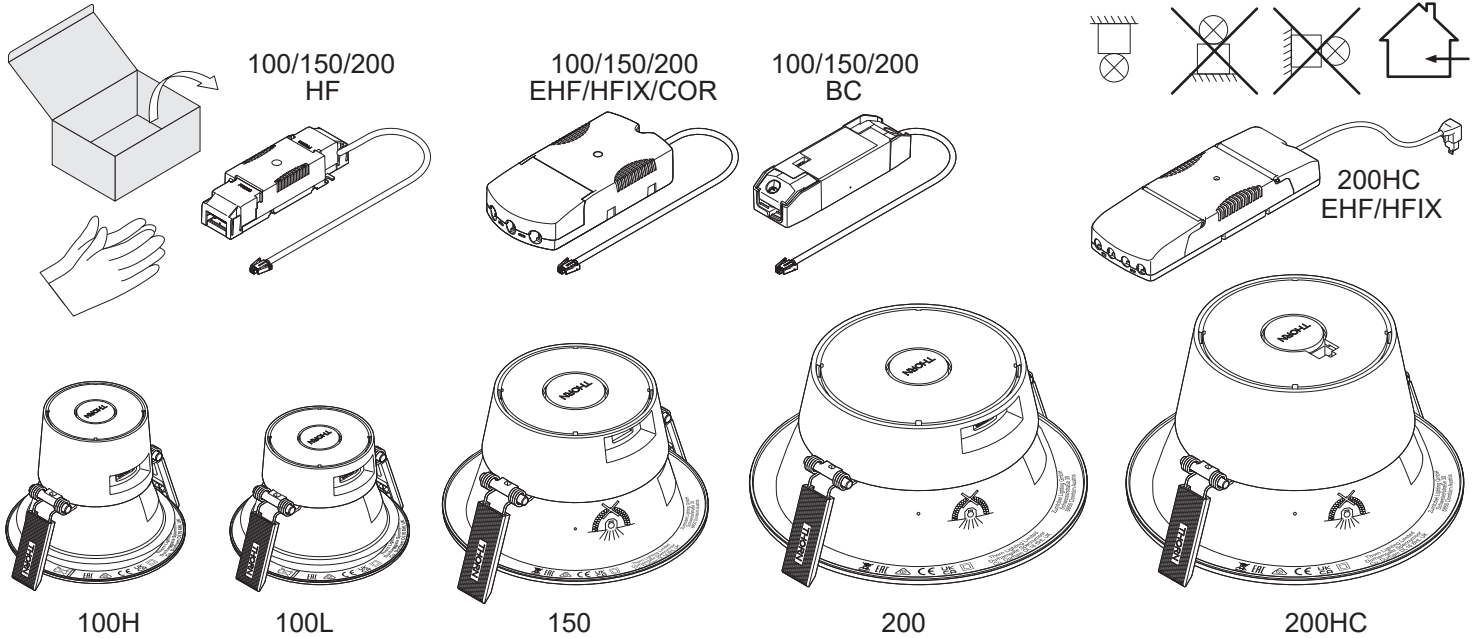

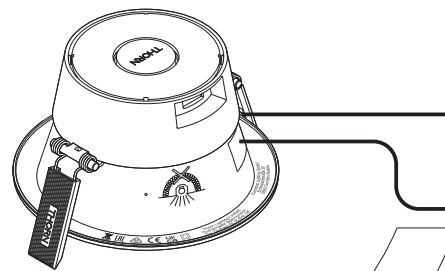

↓ IP20





↑ IP20 - IP65

**THORN**  
 Made in Germany  
 Mod .....  
 Ser ..... ..mA  
 220-240V 50/60Hz ...W  
 CHAL3...



Replaceability instruction

↔

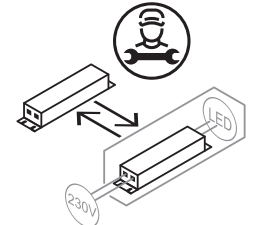

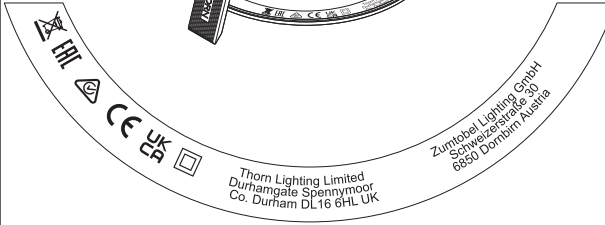

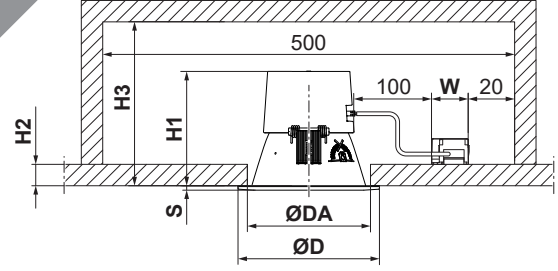
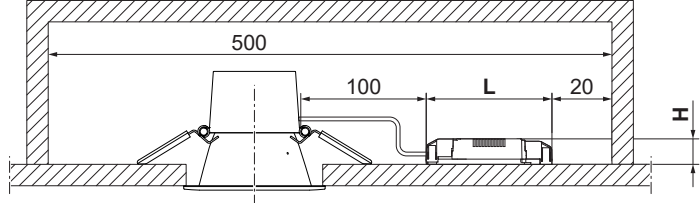
	100 / 150 / 200			200HC
	HF	EHF/HFIX	BC	EHF/HFIX
<b>W</b>	43	82	44	100
<b>L</b>	147	160	147	235
<b>H</b>	30	34	30	31

	100H	100L	150	200	200HC
<b>ØD</b>	119	119	174	223	223
<b>ØDA</b>	100	100	150	200	200
<b>S</b>	3,7	3,7	4	4,2	4,2
<b>H1</b>	95	75	94	96	134
<b>H2</b>	1-40				12,5-40
<b>H3</b>	≥ 100*				≥ 140

\*CRI930 HC 3000lm Ø DA 150 ≥ 150



**EN** Installation and commissioning may only be carried out by authorized specialists.

**DE** Die Montage und Inbetriebnahme darf nur von autorisiertem Fachpersonal durchgeführt werden.

**CS** Montáž a uvedení do provozu smí provádět pouze oprávněný odborný personál.

**DK** Montering og ibrugtagning må kun foretages af autoriseret fagpersonale.

**ET** Montaaži ja kasutuselvõttu tohivad teha üksnes selleks volitatud spetsialistid.

**FI** Asennuksen ja käyttöönoton saa tehdä vain auktorisoitu ammattihenkilöstö.

**FR** L'installation et la mise en service doivent obligatoirement être effectuées par des techniciens.

**HU** Csak szakképzett személyzet végezheti a szerelést és az üzembe helyezést.

**IT** Montaggio ed avviamento devono essere eseguiti solo da personale specializzato.

**LT** Montuoti ir paruošti eksploatacijai gali tik autorizuoti specialistai.

**LV** Veikt uzstādīšanu un nodot ierīci ekspluatācijai drīkst tikai autorizēti specialisti.

**NO** Montasje og igangkjøring må kun utføres av autorisert fagpersonell.

**PL** Montaż i uruchomienie mogą być przeprowadzane wyłącznie przez autoryzowany personel.

**SV** Monteringen och idrifttagandet får endast företas av auktoriserad fackpersonal.

**RU** Монтаж и ввод в эксплуатацию, должны выполняться только авторизованными специалистами.

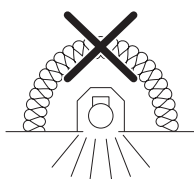

**EN** Luminaire not suitable for covering with thermally insulating material.

**DE** Leuchte darf nicht mit Wärmedämmung abgedeckt werden.

**CS** Světla nesmí být zakryta materiálem tepelné izolace.

**DK** Lampen må ikke tildækkes med varmeisolerende materiale.

**ET** Valgusti ei tohi olla kaetud soojusisolatsioonimaterjaliga.

**FI** Valaisinta ei saa peittää lämpöeristeillä.

**FR** Le luminaire ne doit pas être recouvert d'une isolation thermique.

**HU** A világítótestet hőszigeteléssel ellátni tilos!

**IT** L'apparecchio non va assolutamente coperto da isolamento termico.

**LT** Šviestuvas negalima padengti termoizoliacine medžiaga.

**LV** Lampa nav piemērota aplkāšanai ar termoizolēju materiālu.

**NO** Belysningsarmaturen må ikke tildekkes med varmeisolerende materiale.

**PL** Oprawa nie może być osłonięta materiałem izolacyjnym.

**SV** Armaturen får inte täckas med värmeisolerings.

**RU** Светильник не должен быть закрыт теплоизоляцией.

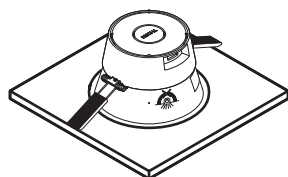

**EN** The lamp is used exclusively for lighting and is to be installed in accordance with the national installation regulations. Any other use or installation is regarded as "not according to instructions".

**DE** Die Leuchte dient ausschließlich der Beleuchtung und ist entsprechend den nationalen Errichtungsbestimmungen zu installieren. Eine andere Nutzung oder ein anderer Einbau gilt als „nicht bestimmungsgemäß“.

**CS** Osvetlovací těleso slouží výlučně k osvětlení a je nutno je nainstalovat v souladu s národními normami týkajícími se pokládá za použití nebo montáž v rozporu s určeným účelem.

**DK** Lampen er udelukkende beregnet til belysning, og skal installeres iht. de nationale installationsbestemmelser. En anden brug eller en anden monteringsgælder som "ikke formålsbestemt".

**ET** Valgustit tohib kasutada üksnes valgustamiseks ja see tuleb paigaldada vastavalt riiklikele paigalduseeskirjadele. Muul otstarbel kasutamine või paigaldamine loetakse „eeskirjadele mittevastavaks“.

**FI** Valaisin on tarkoitettu ainoastaan valaistuskäyttöön, ja se on asennettava kansallisten määräysten mukaan. Muu käyttö tai muu asennus katsotaan sopimuksenvastaiseksi käytöksi.

**FR** La lampe sert uniquement à l'éclairage et doit être installée conformément aux prescriptions nationales en matière d'installation. Toute autre utilisation ou installation est considérée comme "non conforme".

**HU** A lámpa kizárólag világításra szolgál és a felszerelésre vonatkozó országos rendelkezéseknek megfelelően kell felszerelni. Ettől eltérő használat vagy beépítés "nem rendeltetésszerűnek" számít.

**IT** La lampada serve esclusivamente per l'illuminazione e deve essere installata in conformità con le norme nazionali per il montaggio. Un altro uso o un diverso tipo di incasso non è considerato conforme alle disposizioni.

**LT** Šviestuvas skirtas tik apšvietimui ir turi būti irengiamas laikantis nacionaliniu irengimo nuostatu. Kitoks naudojimas ar irengimas laikomas „ne pagal paskirti“.

**LV** Lampu paredzets izmantot tikai apgaismošanas nolukos, un ta jāuzstāda atbilstoši valsts noteikumiem par ierīcu uzstādīšanu. Jebkāda citādāka lietošana vai uzstādīšana tiek uzskatīta par "neatbilstošu instrukcijai".

**NO** Lysene skal kun brukes til belysning, og må installeres i overensstemmelse med de nasjonale forskrifter. Annen bruk eller annen montasje blir betraktet som "ikke tiltenkt".

**PL** Lampa służy wyłącznie do oświetlenia i należy ją zamontować zgodnie z krajowymi przepisami wykonawczymi. Inne wykorzystanie lub inny montaż są uznawane za „niezgodne z przeznaczeniem“.

**SV** Lampan är utslutande avsedd för belysning och skall installeras i enlighet med de nationella installationsbestämmelserna. All annan användning eller monteringsgäller som "ej ändamålsenlig".

**RU** Светильник предназначен только для освещения и должен устанавливаться в соответствии с национальными монтажными нормами.

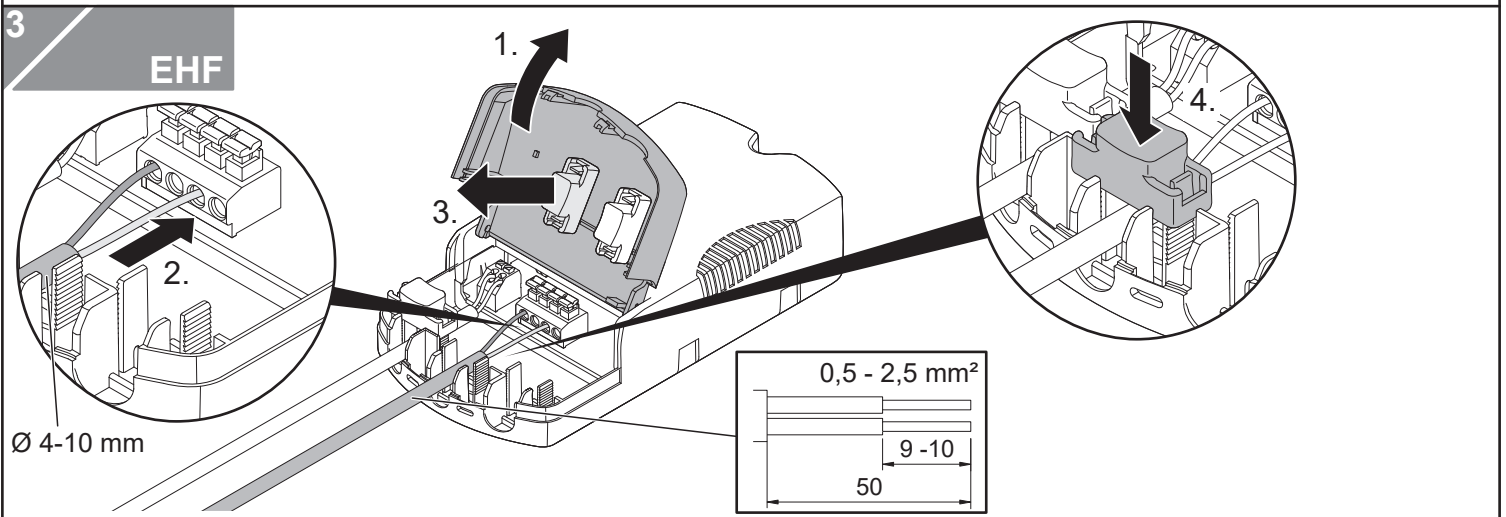
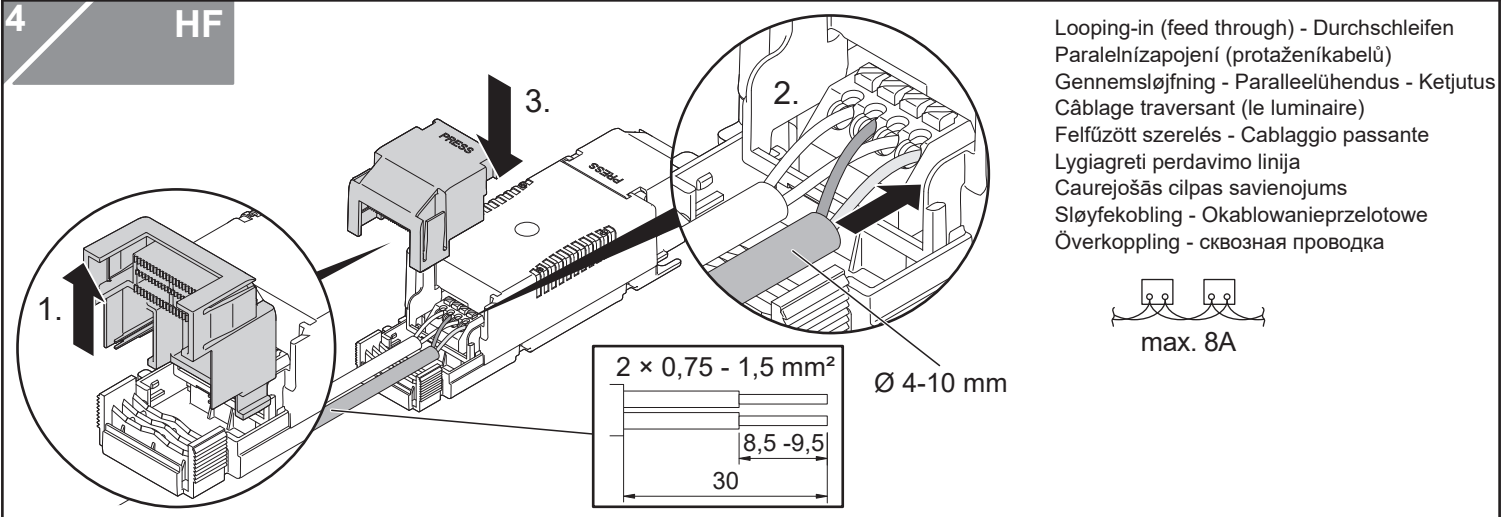
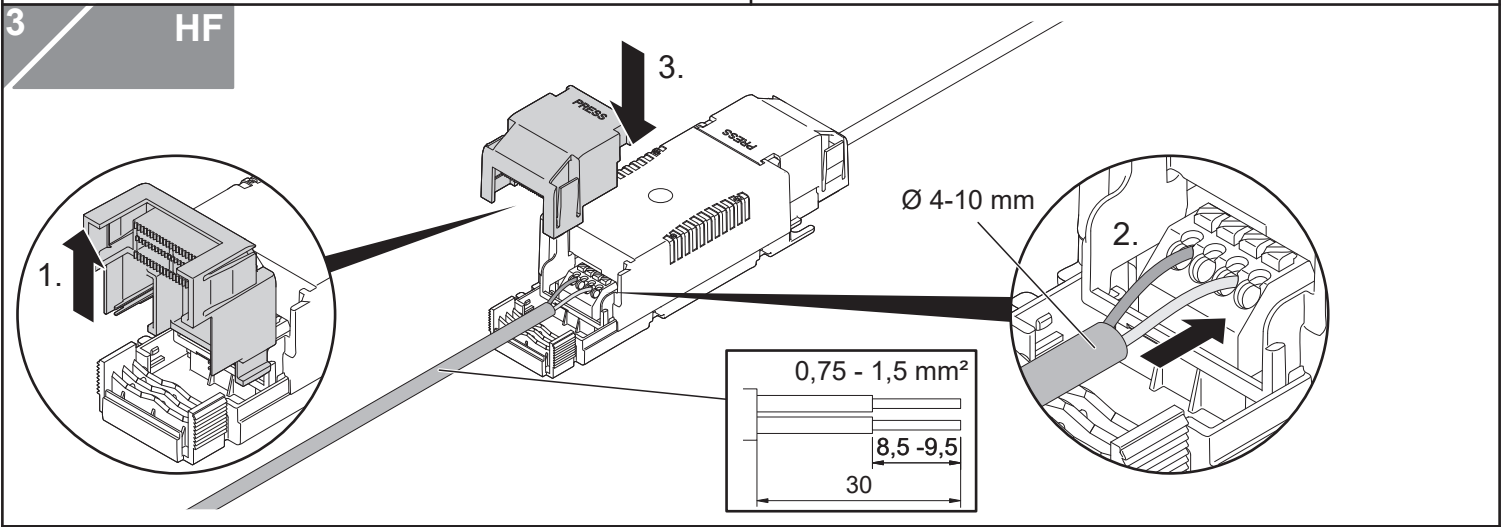
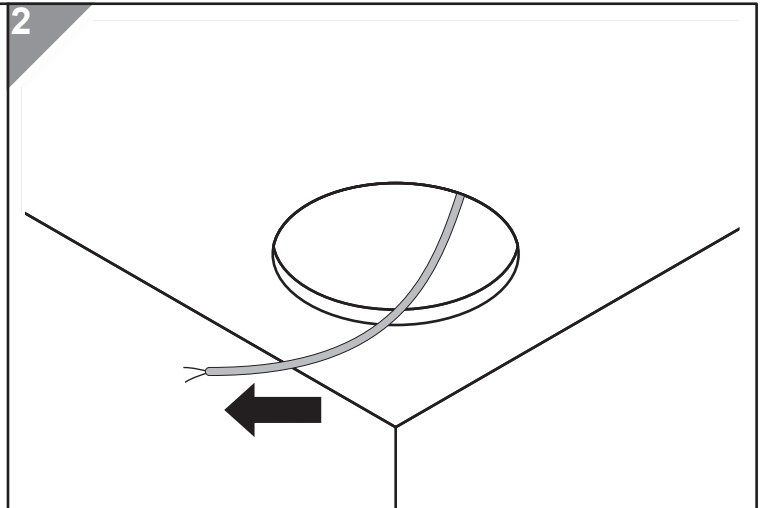
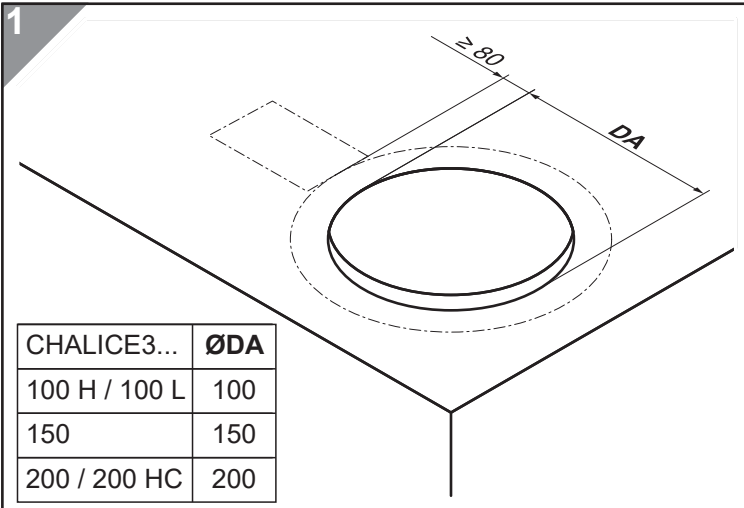

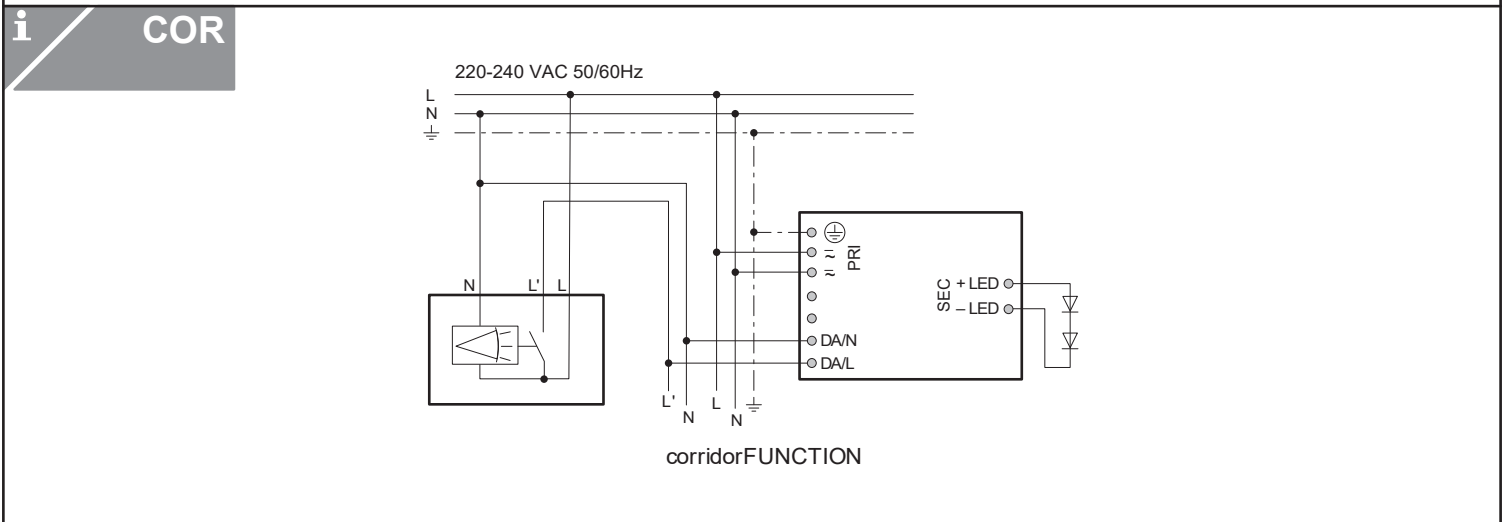
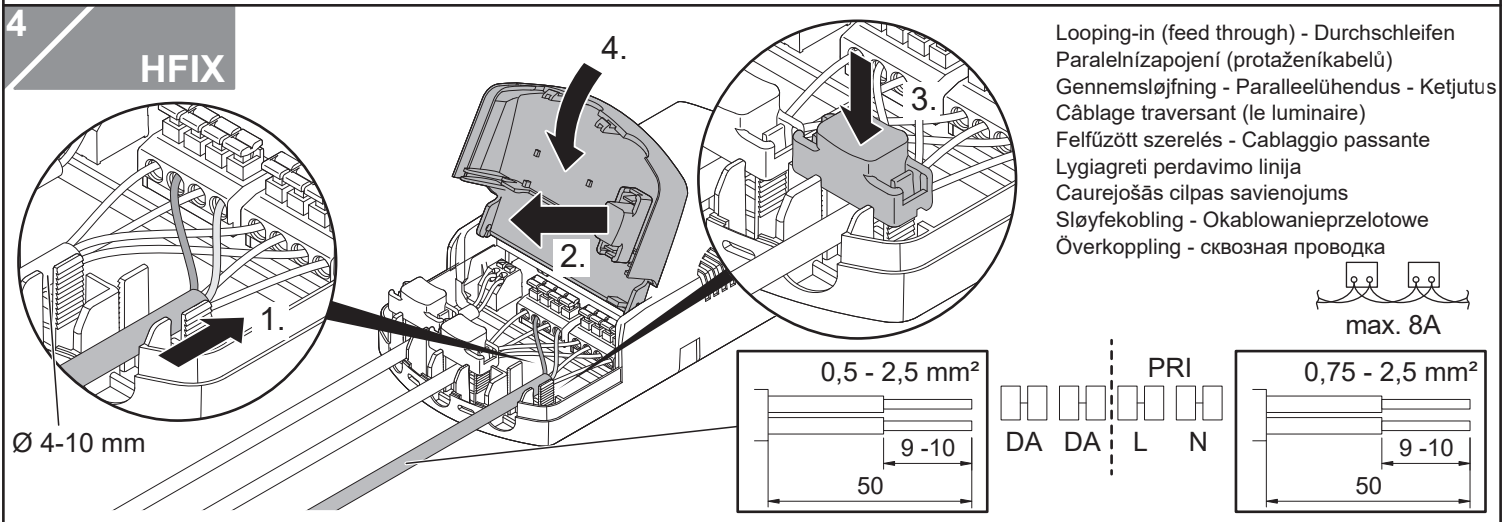
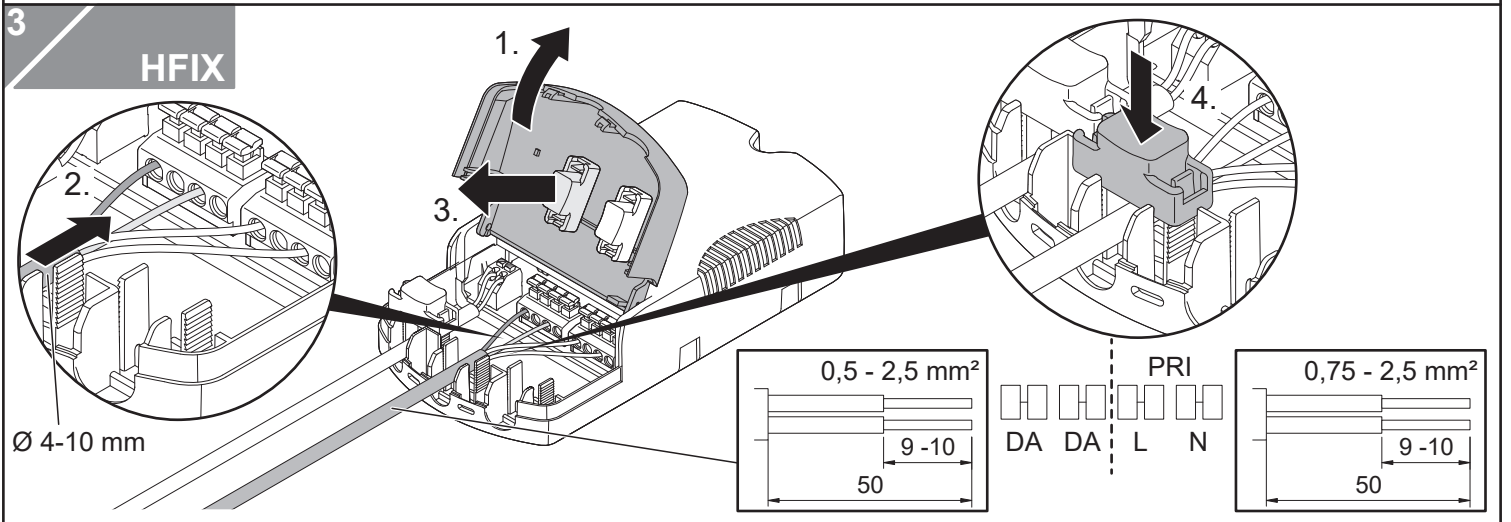
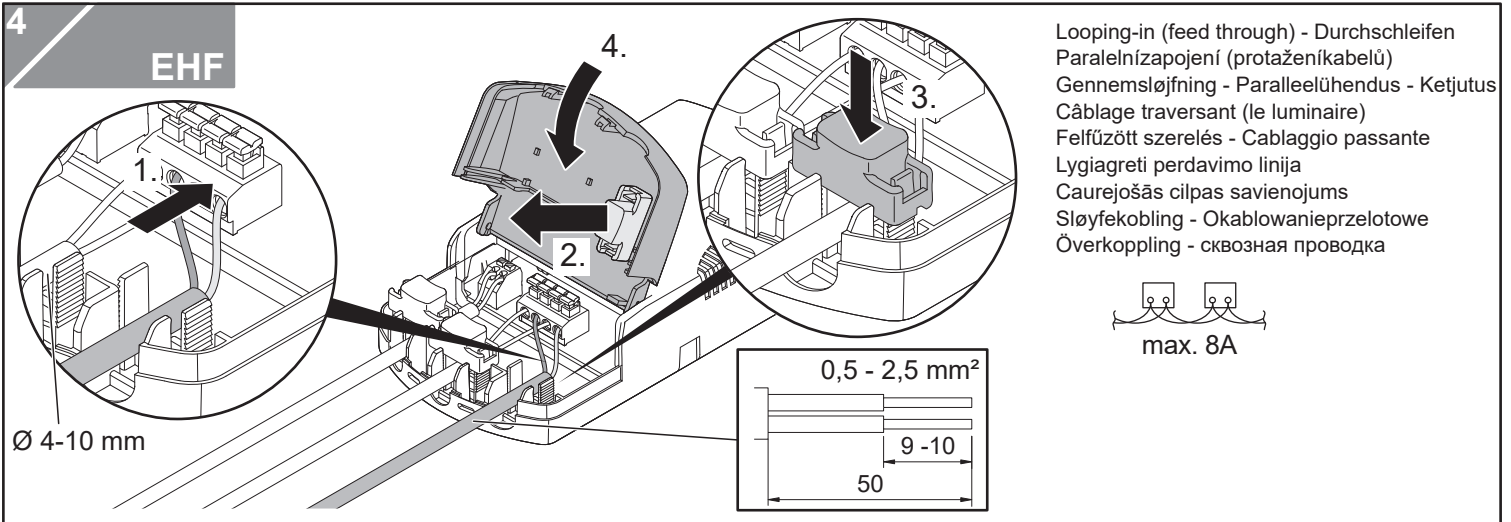

3 BC

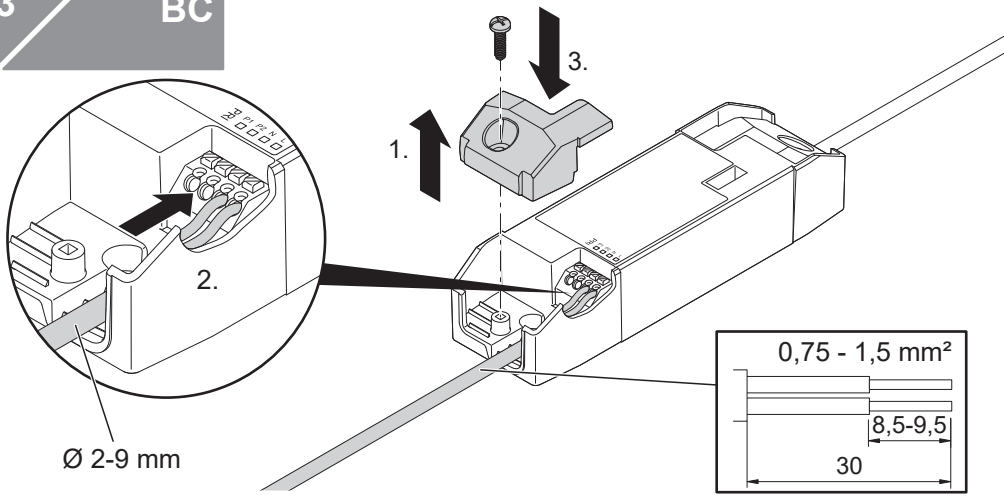

~~Looping-in (feed through) - Durchschleifen  
 Paralelnízapojení (protaženíkabelů)  
 Gennemsløjfning - Paralleelühendus - Ketjutus  
 Câblage traversant (le luminaire)  
 Felfűzött szerelés - Cablaggio passante  
 Lygiagreti perdavimo linija  
 Caurejošās cilpas savienojums  
 Sløyfekobling - Okablowanieprzetowe  
 Överkoppling - сквозная проводка~~

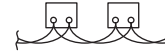

i switch DIM

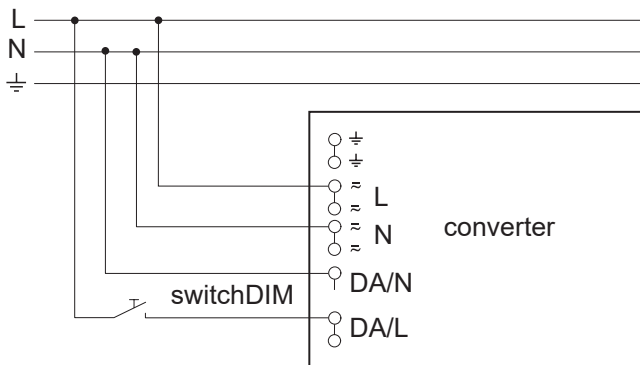

i

- |           |                                    |
|-----------|------------------------------------|
| <b>EN</b> | Protected earthing not required    |
| <b>DE</b> | Erdung nicht erforderlich          |
| <b>FR</b> | Mise à la terre dispensable        |
| <b>IT</b> | Messa a terra non necessaria       |
| <b>NL</b> | Beschermende aarde is niet vereist |
| <b>SV</b> | Skyddsjord krävs inte              |
| <b>FI</b> | Suojamaadoitus ei tarvita          |
| <b>ES</b> | Puesta a tierra no require         |
| <b>ZH</b> | 受保護的接地不是必需的                        |
| <b>RU</b> | Защищенное заземление не требуется |

3 EHF HC

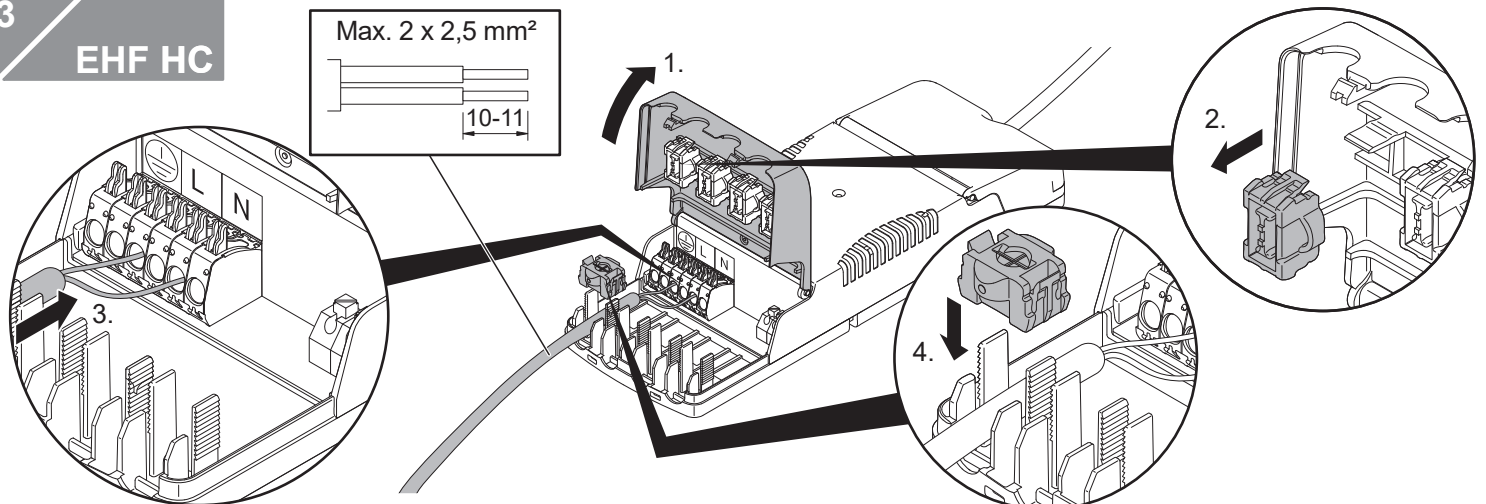

4 EHF HC

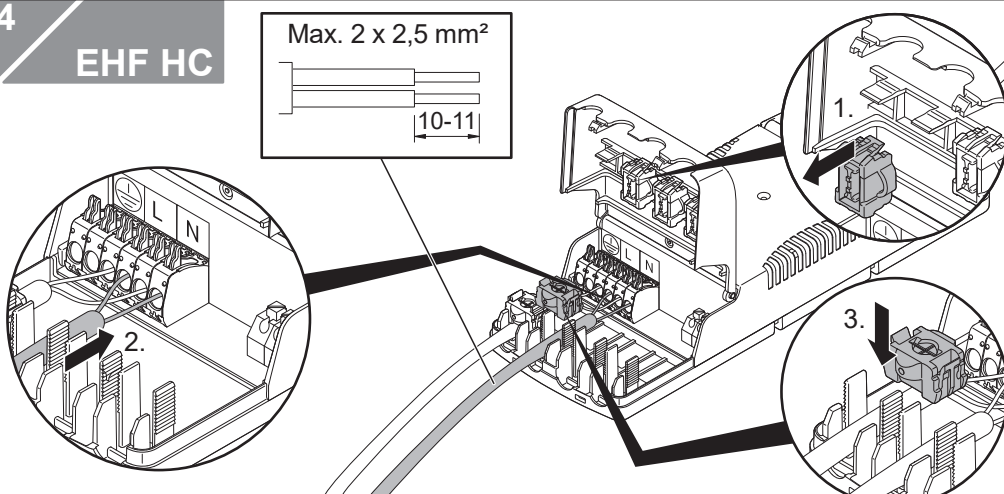

Looping-in (feed through) - Durchschleifen  
 Paralelnízapojení (protaženíkabelů)  
 Gennemsløjfning - Paralleelühendus - Ketjutus  
 Câblage traversant (le luminaire)  
 Felfűzött szerelés - Cablaggio passante  
 Lygiagreti perdavimo linija  
 Caurejošās cilpas savienojums  
 Sløyfekobling - Okablowanieprzetowe  
 Överkoppling - сквозная проводка

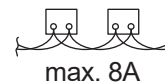

3

HFIX HC

Max. 2 x 2,5 mm<sup>2</sup>

10-11

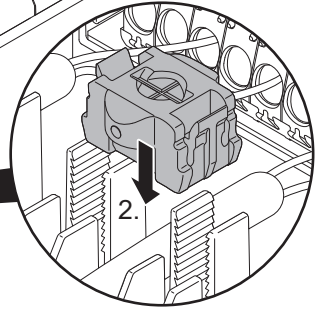
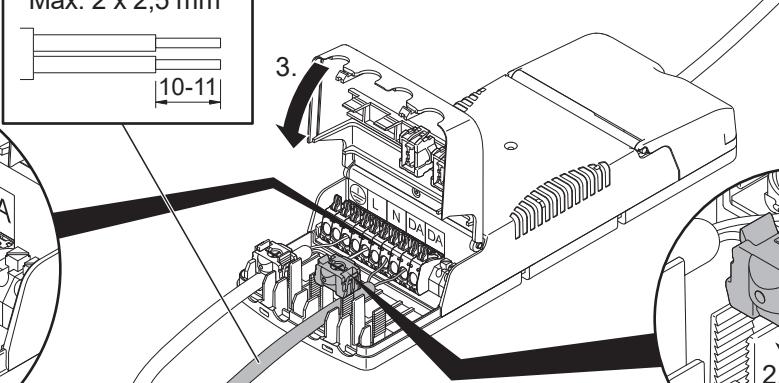
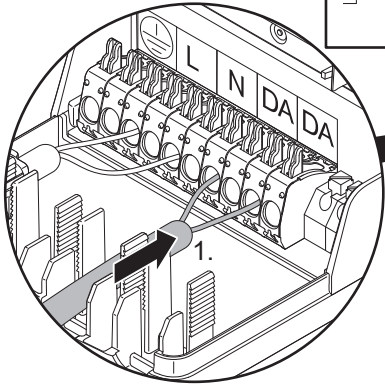

4

HFIX HC

Max. 2 x 2,5 mm<sup>2</sup>

10-11

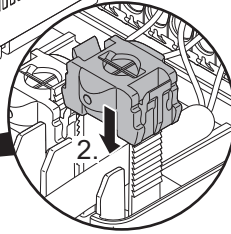
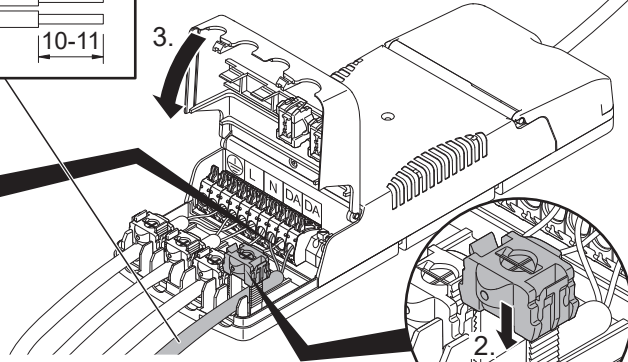
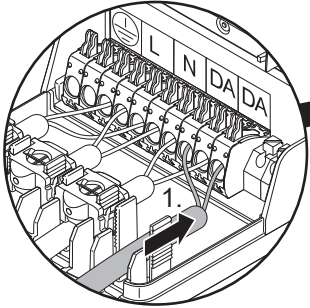

Looping-in (feed through) - Durchschleifen  
 Paralelnízapojení (protaženíkabelů)  
 Gennemsløjfning - Paralleelühendus - Ketjutus  
 Câblage traversant (le luminaire)  
 Felfűzőtt szerelés - Cablaggio passante  
 Lygiagreti perdavimo linija  
 Caurejošās cilpas savienojums  
 Słójfekobling - Okablowanieprzetowe  
 Överkoppling - сквозная проводка

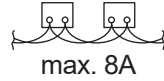

max. 8A

5

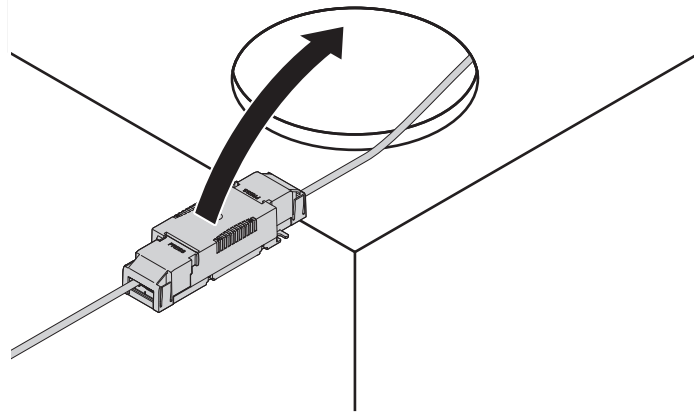

6

Option/  
Accessory 96239327

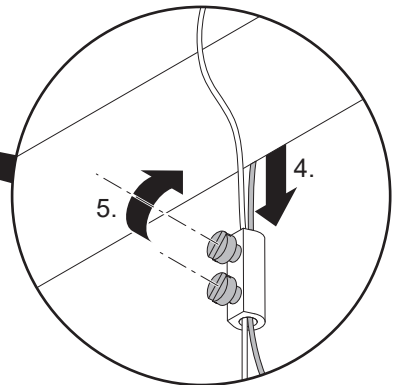
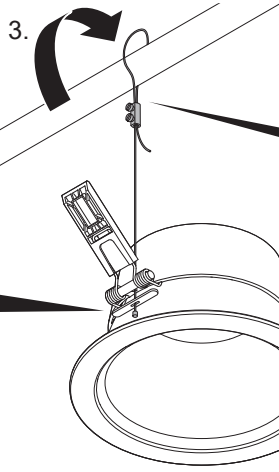
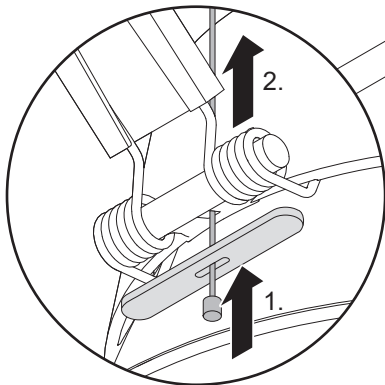

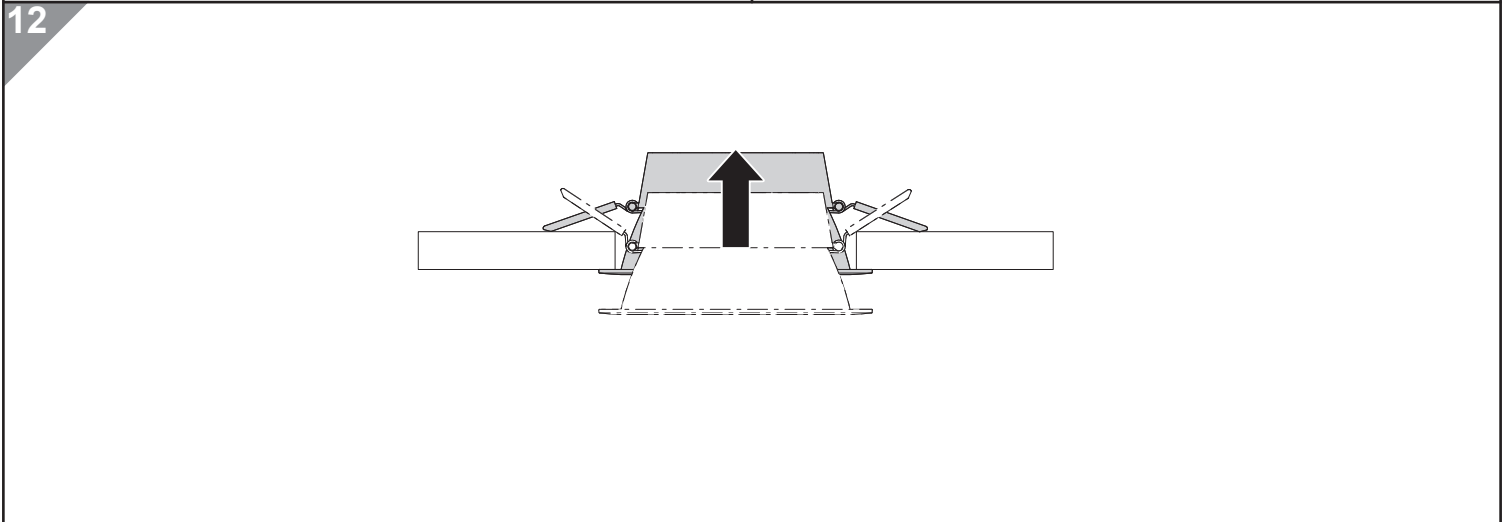
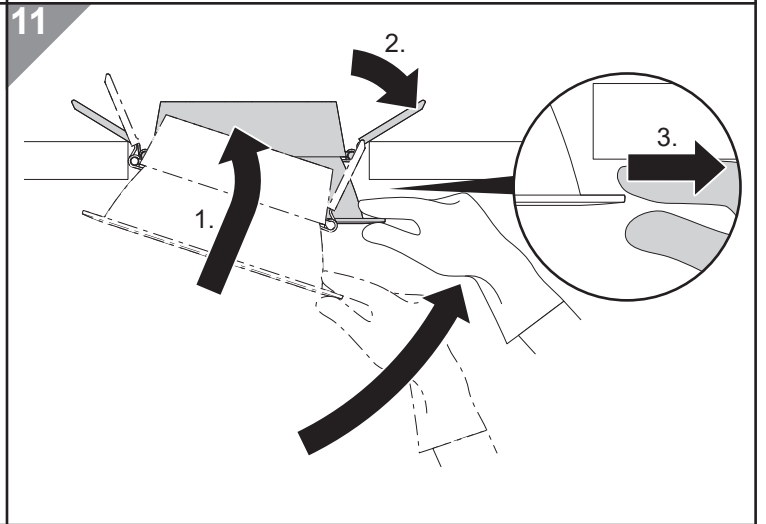
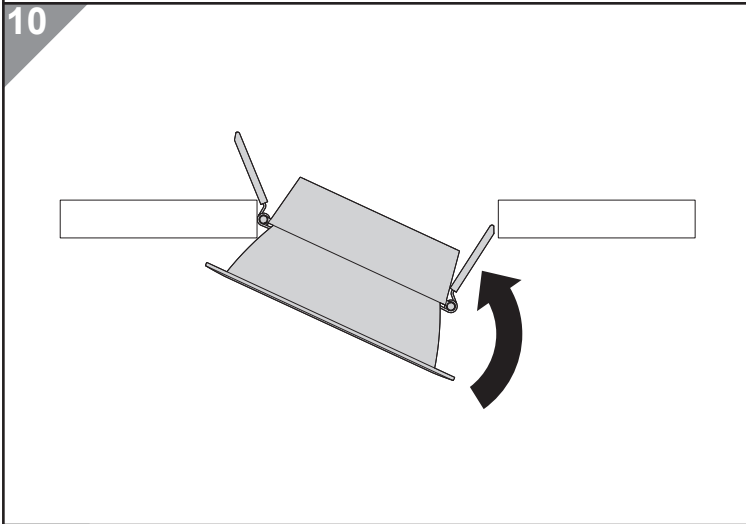
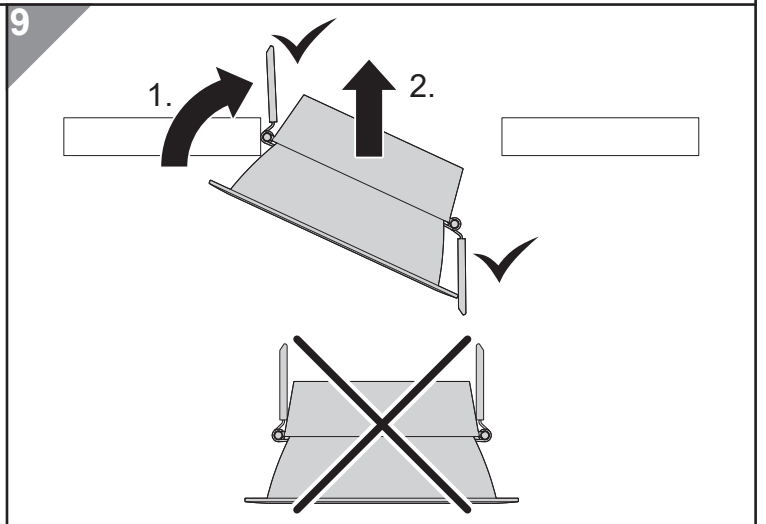
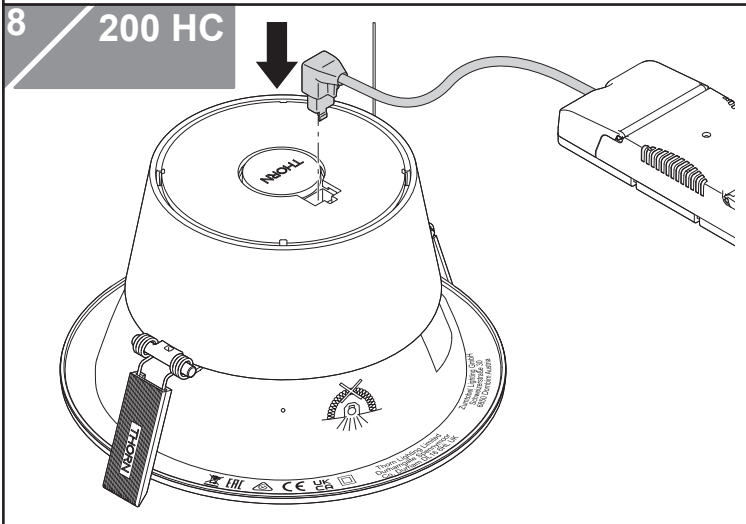
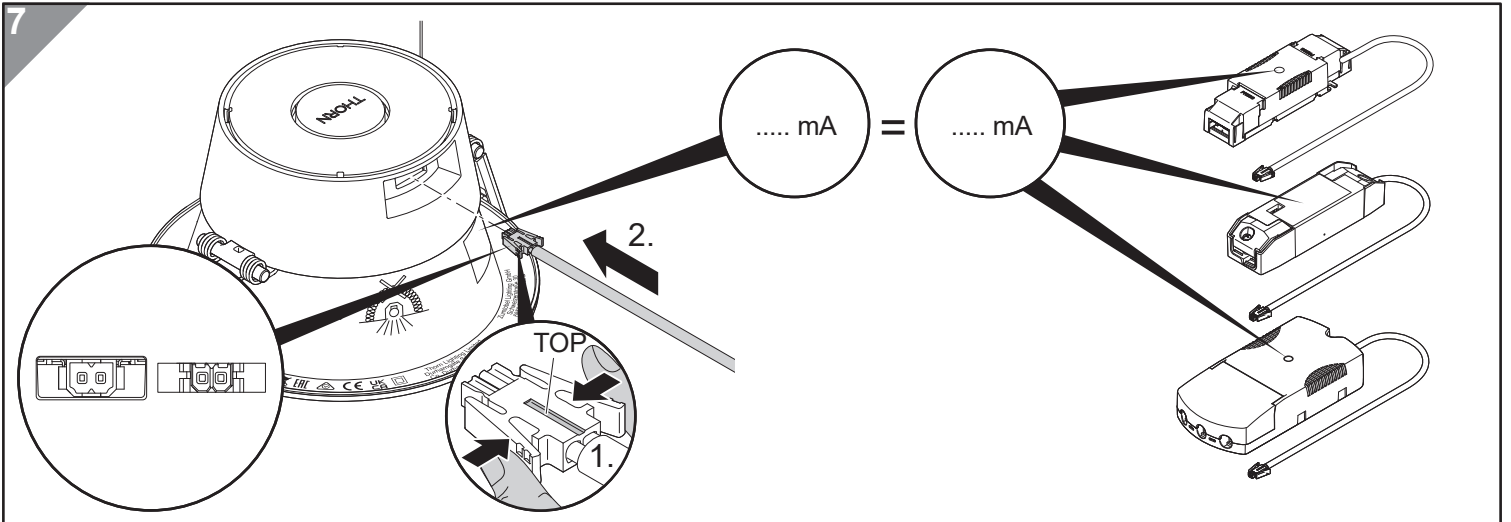

1

Dismantling - Demontage - Demontáž - afmontering  
demonteerimine - Purkaminen - Démontage - szétszerelés  
Smontaggio - išmontavimas - demontāža - Demontering  
Demontaž - Demontering - Демонтаж

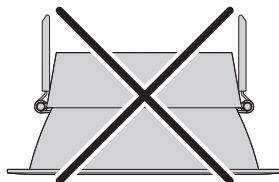
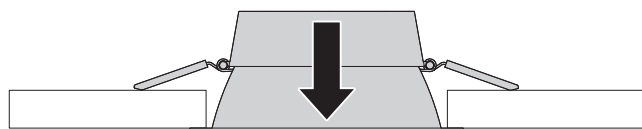

2

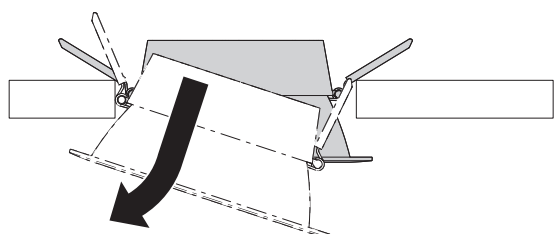

3

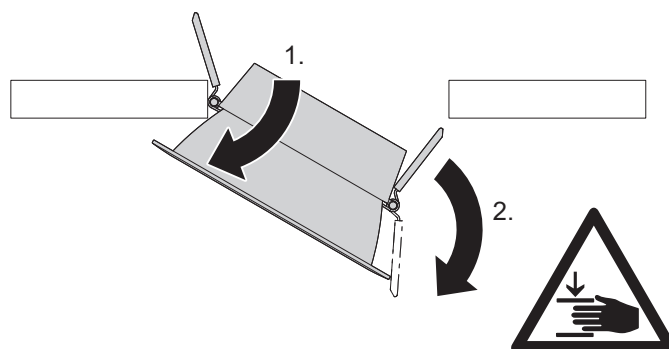

4

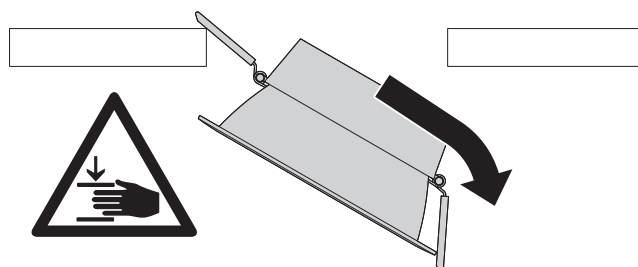



Accessory - Zubehör - Príslusenství - Tilbehør - Lisatarvikud - Lisätarvike - Accessoire éventuel - tartozékok  
 Accessori - Priedai - Piederumi - Tillbehör - Akcesoria - Tillbehör - Принадлежности

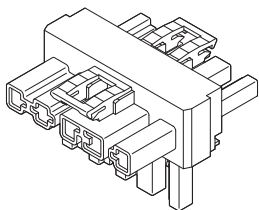

- 96635254 T CONNECTOR WO 3POLE
- 96635255 T CONNECTOR WO 5POLE
- 96635256 T CONNECTOR WL 3POLE
- 96635257 T CONNECTOR WL 5POLE

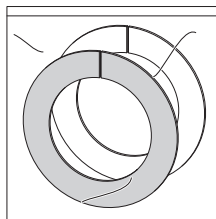

- 96633598 CHALICE/CETUS3 200 CEILING RING 250MM WH
- 96633599 CHALICE 200 CEILING RING 230-240 WH
- 96633600 CHALICE 200 CEILING RING 210-220 WH
- 96633602 CHALICE 150 CEILING RING 180-190 WH
- 96633601 CHALICE 150 CEILING RING 160-170 WH
- 96108712 CHAL3 100 CEILING RING 110-120 WH
- 96108713 CHAL3 100 CEILING RING 130-140 WH



96239327

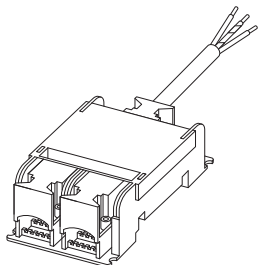

96635252 DL CONNECTION BOX 3P TERM+LINECT

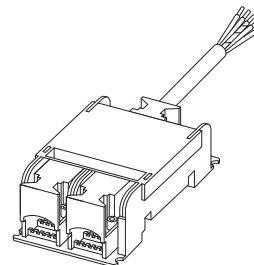

96635253 DL CONNECTION BOX 5P TERM+LINECT

Download Tridonic basic DIM Wireless Control App  
 if you have Bluetooth (BC) Luminaires



APP



Tridonic basic DIM Wireless ControlApp



App Documentation [DE]



App Dokumentation [EN]