

- SLN2 MSC+MSP
- MSC (surface-mounted)
- MSP (pendant)
- SL (single luminaire)
- LB (continuous row luminaires)
- emergency lighting (centrally supplied)

- |                    |                      |
|--------------------|----------------------|
| - BWS (ball proof) | - MC (minicell)      |
| - IP54             | - DD (drop-diffuser) |
| - DI/ID            | - PC (opal)          |
| - CL (corner)      | - PCO (office optic) |
| - L-X-T            | - WW (wall washer)   |



**EN Mounting instructions**  
Important notices. Please, read first! Keep the instructions safe! Specifications are subject to change without notice! If you have questions, please contact the manufacturer.

**DE Montageanleitung**  
Wichtige Hinweise. Bitte zuerst lesen! Anleitung aufbewahren! Technische Änderungen vorbehalten! Bei Fragen wenden Sie sich an den Hersteller.

**FR Notice de montage**  
Remarques importantes. À lire en premier lieu! Conservez cette notice! Modifications techniques sans préavis! Si vous avez des questions, veuillez contacter le fabricant.

**IT Istruzioni di montaggio**  
Nota importanti. Si prega di leggere prima! Conservare le istruzioni! Modifiche tecniche senza preavviso! Per chiarimenti rivolgersi al produttore.

**ES Instrucciones de montaje**  
Notas importantes. Por favor, lea primero! ¡Guarde las instrucciones! ¡Reservado el derecho de realizar modificaciones técnicas sin preaviso! Si tiene alguna pregunta, póngase en contacto con el fabricante.

**NL Montagehandleiding**  
Belangrijke informatie. Gelieve eerst te lezen! Houd deze gebruiksaanwijzingen zorgvuldig bij! Technische wijzigingen blijven voorbehouden! Als u vragen hebt, kan u contact opnemen met de fabrikant.

**SV Installationsanvisning**  
Viktigt information. Läs först! Spara anvisningen! Med reservation för tekniska ändringar! Om du har frågor ber vi dig ta kontakt med tillverkaren.

**FI Asennusohje**  
Tärkeä huomautus. Lue ensin! Säilytä käyttöopas! Oikeudet teknisiin muutoksiin pidätetään! Lähetä mahdolliset kysymykset valmistajalle.

**RU Инструкция по монтажу**  
Важная информация. Просьба ознакомиться перед началом работ! Сохраняйте инструкцию! Компания сохраняет за собой право на внесение технических изменений. При возникновении вопросов обращайтесь к производителю.

**PL Instrukcja montażu**  
Ważne wskazówki/ uwagi. Proszę pierwsze przeczytać całość instrukcji. Proszę zachować instrukcję! Zastrzega się prawo do wprowadzania zmian technicznych. W razie pytań skontaktuj się z producentem.

**ZH 安装说明**  
重要提示。请先阅读! 保留本说明!  
请勿执行技术变动!  
如有问题, 请咨询制造商。

**AR تعليمات التركيب**  
ملاحظات هامة. يرجى القراءة أولاً!  
إبقاء التعليمات!  
تخضع المواصفات للتغيير دون تقديم إشعار!  
إذا كان لديك أسئلة، الرجاء الاتصال بالشركة المصنعة.

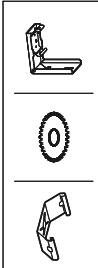
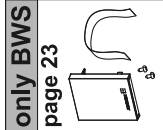
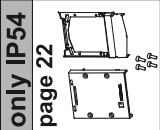

**MOUNTING OPTIONS:**  
surface-mounted /  
pendant / ball prof /  
wall mounting

**2/3**  
pages 8-13

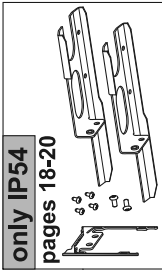

**4 (LB)**  
pages 16+17



< 4000 mm



> 4000 mm

**5**  
page 20

**1**  
page 8

**8 (LB)**  
page 26

**7 (LB)**  
page 25

**6**  
page 24

**9**  
page 27

only MC  
page 28

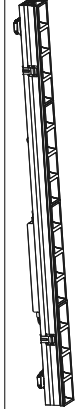

**MOUNTING OPTION:**  
wallwasher  
**(10)**  
page 29

**11**  
pages 29+30

only BWS  
page 33

only IP54  
page 32

**MOUNTING OPTION CORNER**  
page 14+15/ 31  
L-X-T

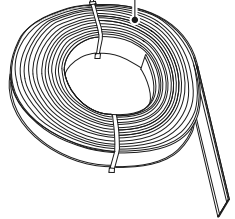

**MOUNTING OPTION:**  
DD (drop-diffuser)  
**(12)(LB)**  
page 34

# **i** TABLE OF CONTENTS / INHALTSVERZEICHNIS:

## **step 1**

channel **page 8**

---

## **step 2 - MOUNTING OPTIONS:**

MSC (surface-mounted) **pages 8-11**

MSP (pendant) **pages 11+12**

MWS (ball proof) **page 12**

---

## **step 3 - MOUNTING OPTIONS:** **page 13**

MSC (surface-mounted)

MSP (pendant)

MSW (wall-mounting)

corner L-X-T **page 14+15**

---

## **step 4**

connector modules **pages 16+17**

connector modules IP54 **pages 18-20**

---

## **step 5**

Endcaps **page 21**

Endcaps (IP54) **page 22**

Endcaps (BWS) **page 23**

---

## **step 6**

electrics **page 24**

---

## **step 7**

electrics - DI/ID / connection **page 25**

---

## **step 8**

Tape SET **page 26**

---

## **step 9**

batten **page 27**

batten MC (minicell) **page 28**

---

## **step (10)**

OPTIC OPTION: wallwasher **page 29**

---

## **step 11**

Cover + mask plate **pages 30+31**

Cover + (corner) **page 31**

Cover + mask plate (IP54) **page 32**

Cover + mask plate (BWS) **page 33**

---

## **step (12)**

DD (drop-diffuser) **page 34**

**SL** single luminaire 

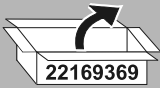
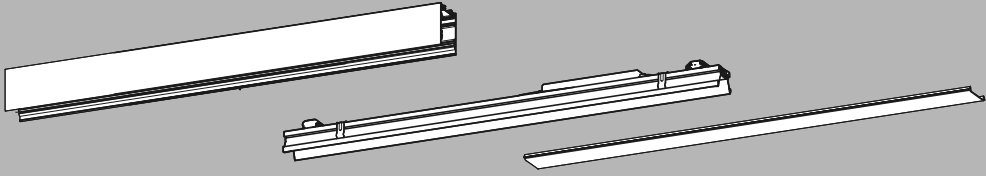

22169369



ZUMTOBEL

**MSC/MSP EC SET**

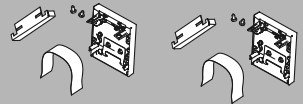

**MC** MC=(Minicell)

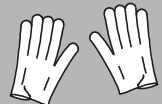
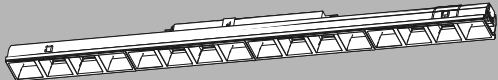

~~BWS~~ ~~IP54~~

22171440

**LB** continuous row 

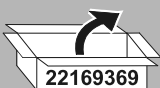
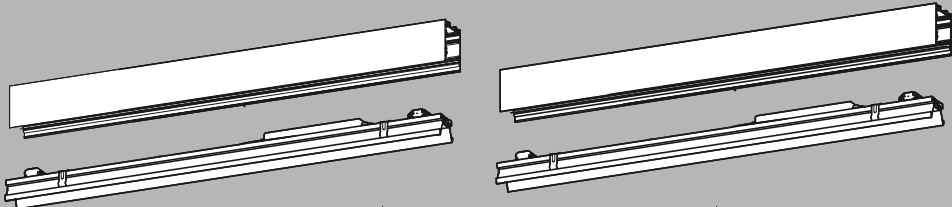

22169369



www.zumtobel.com

22172260

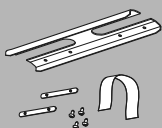

www.zumtobel.com

22172354

**MSC/MSP EC SET**



ZUMTOBEL

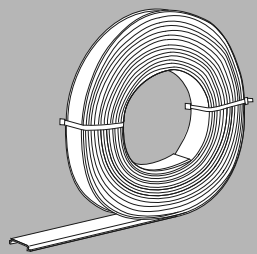
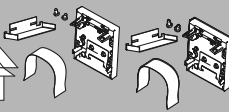

**MC** MC=(Minicell)

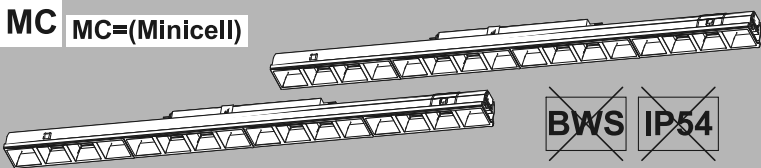

~~BWS~~ ~~IP54~~

22171440



**SL LB IP54**

**IP54 EC SET**



**WH** 22172328

**SR** 22172327

**BK** 22172339

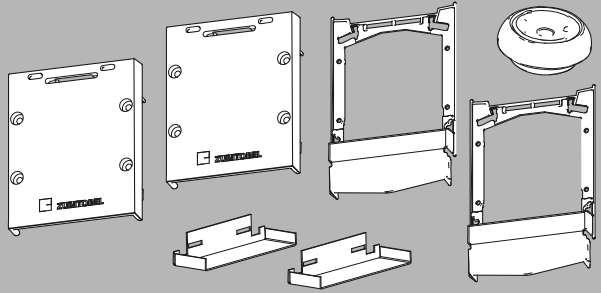

**IP54 CON SET**

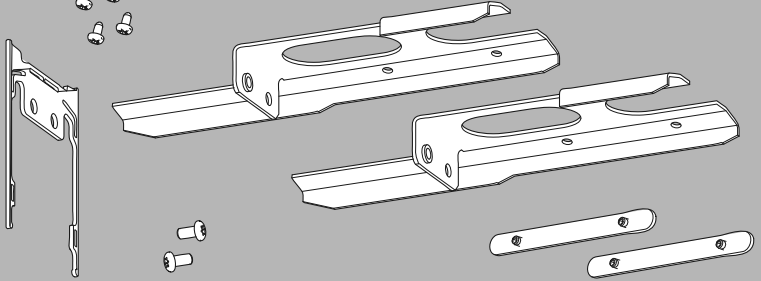

**SL LB BWS**

**BWS EC SET**

**WH** 22172322

**SR** 22172321

**BK** 22172323

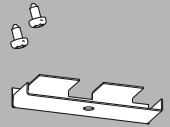
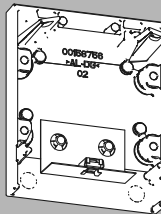

# i MOUNTING OPTIONS

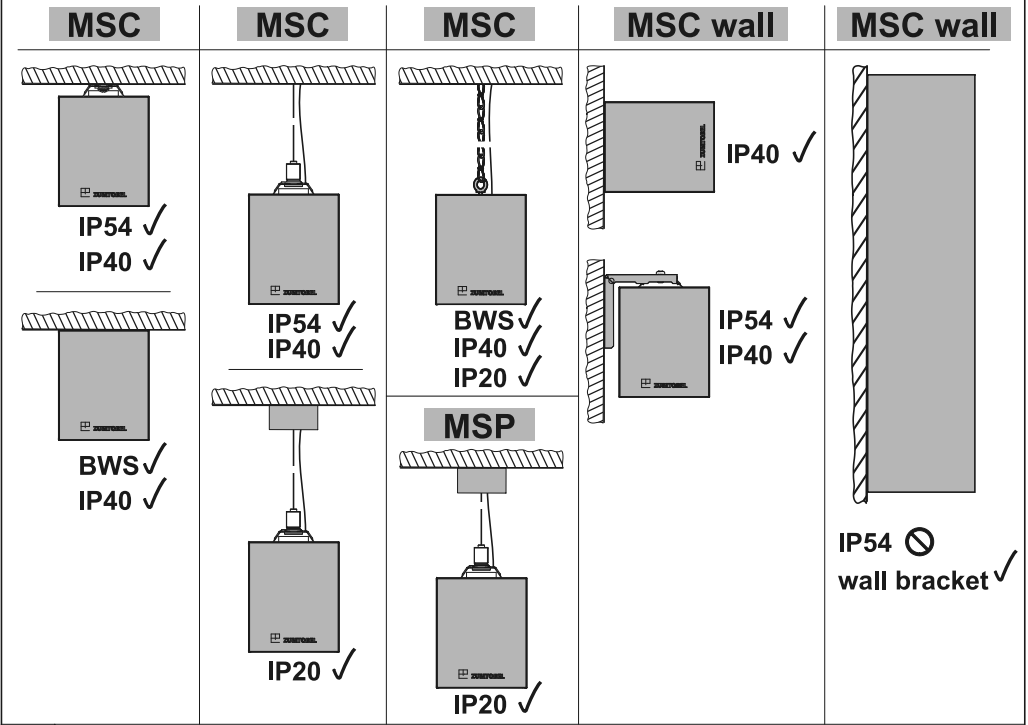

# i MOUNTING OPTION wall-mounting ( BWS / IP54 / wall bracket )

i pages 9+10

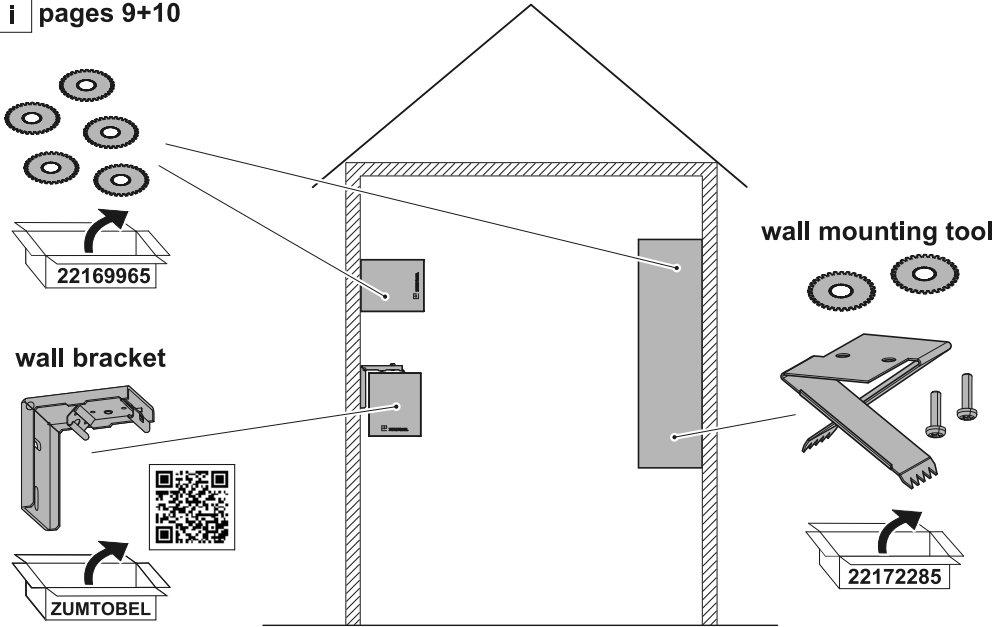

**i MOUNTING OPTION: MSC (surface-mounted)**

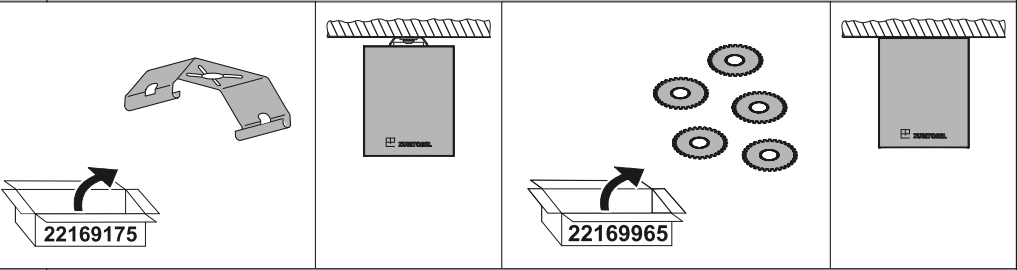

**i MOUNTING OPTION: MSW (wall-mounting)**

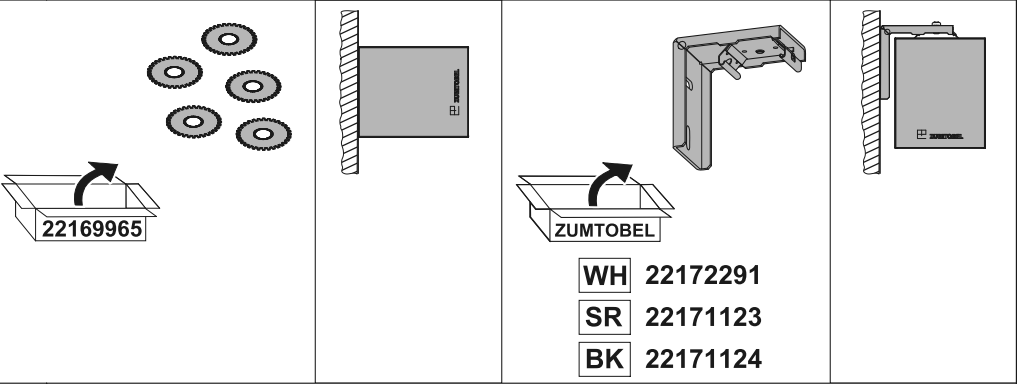

**i MOUNTING OPTION: MSP (pendant)**

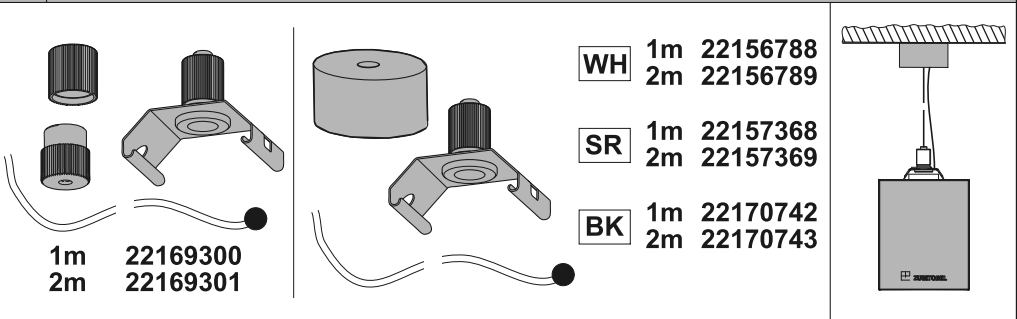

**i MOUNTING OPTION: BWS (ball proof)**

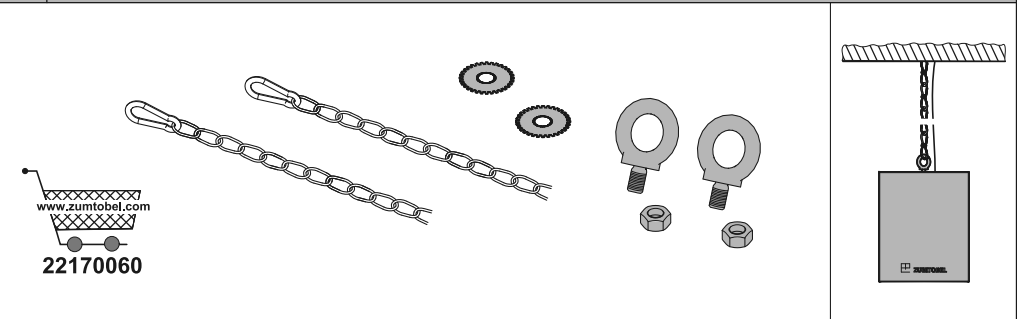

1

1a

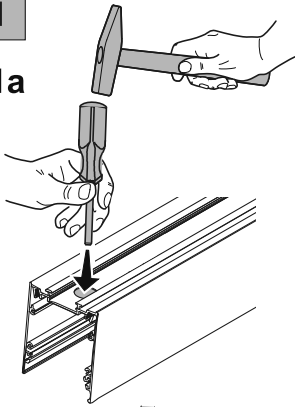

OPTION: IP54

2x ...

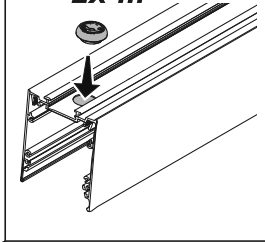

1b

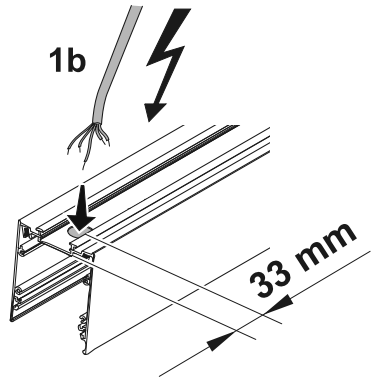

33 mm

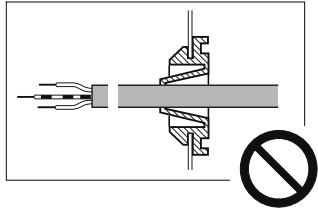
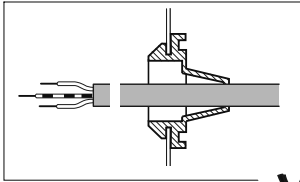
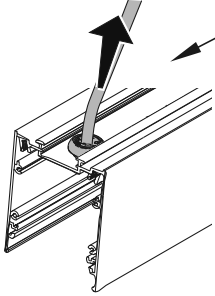

## 2 MOUNTING OPTION: MSC (surface-mounted)

2a

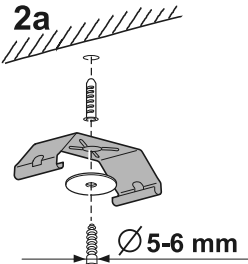

Ø 5-6 mm

2b

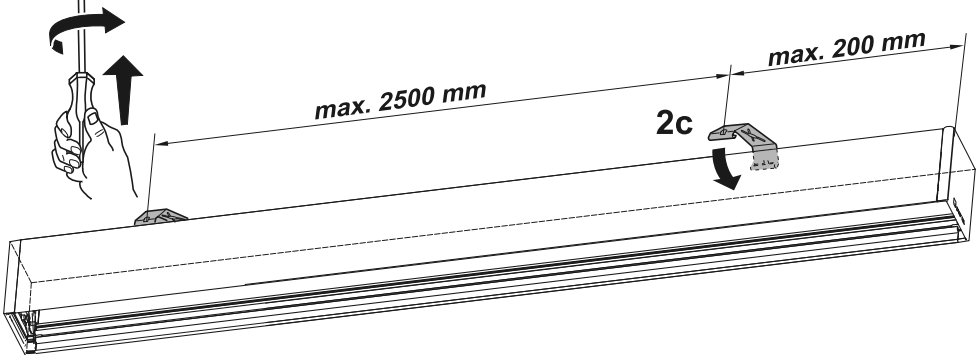
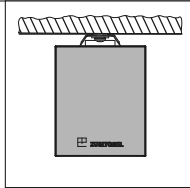
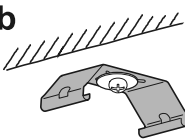

max. 2500 mm

max. 200 mm

2c

## 2 MOUNTING OPTION: MSC (surface-mounted)

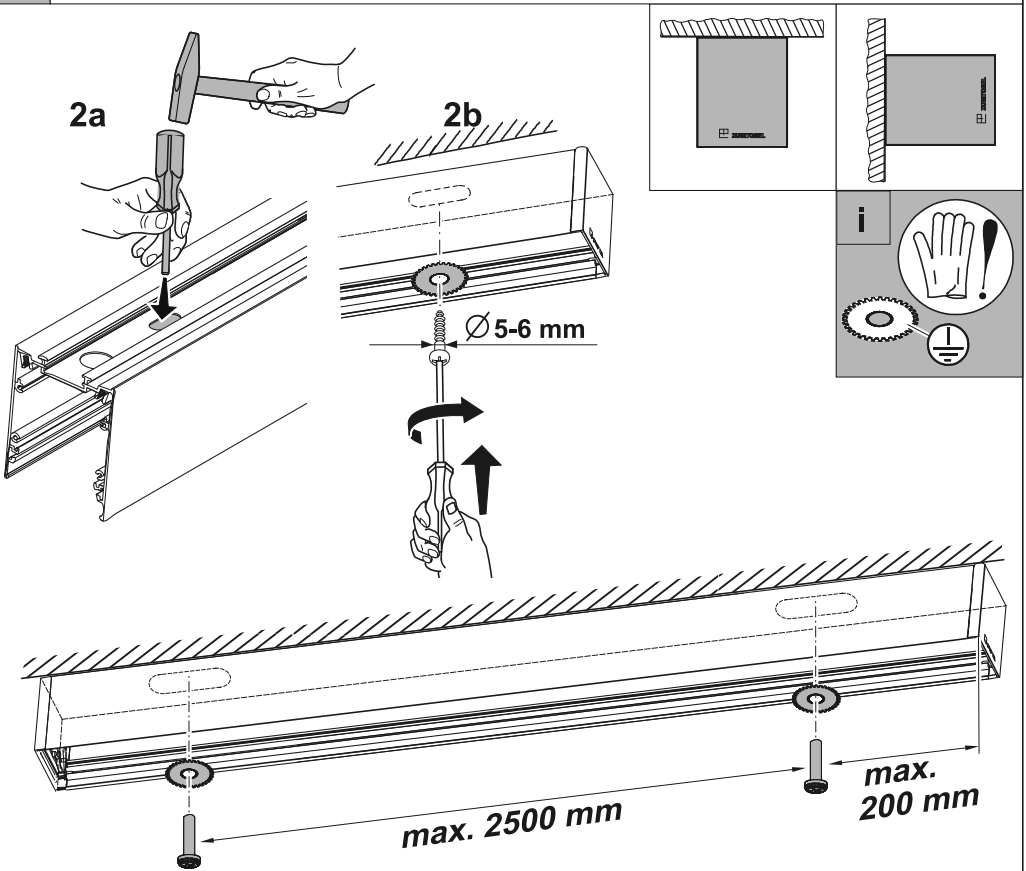

## 2 MOUNTING OPTION: MSC wall (L-bracket)

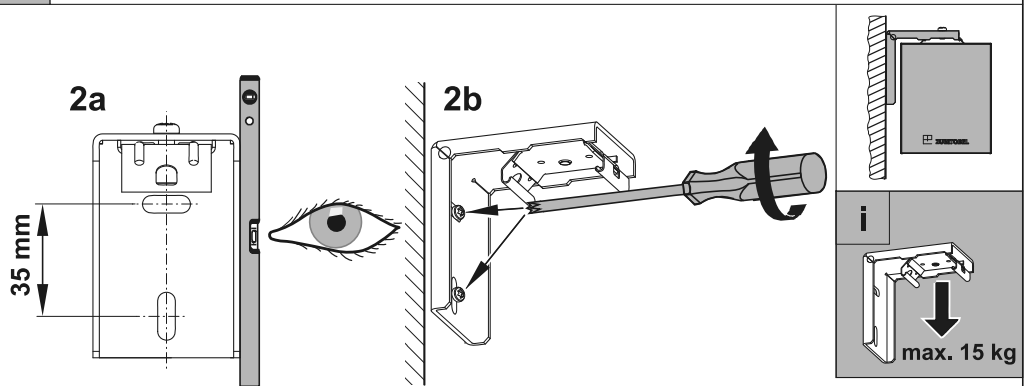

	L1	L2	L3
	1000 mm	100 mm	-
	1250 mm	100 mm	-
	1500 mm	100 mm	-
	1750 mm	100 mm	-
	2000 mm	100 mm	-
	2250 mm	100 mm	1025 mm
	2500 mm	100 mm	1150 mm
	2750 mm	100 mm	1275 mm
	3000 mm	100 mm	1400 mm
	3250 mm	100 mm	1275 mm
	3500 mm	100 mm	1400 mm
	3750 mm	100 mm	1775 mm
	4000 mm	100 mm	1900 mm

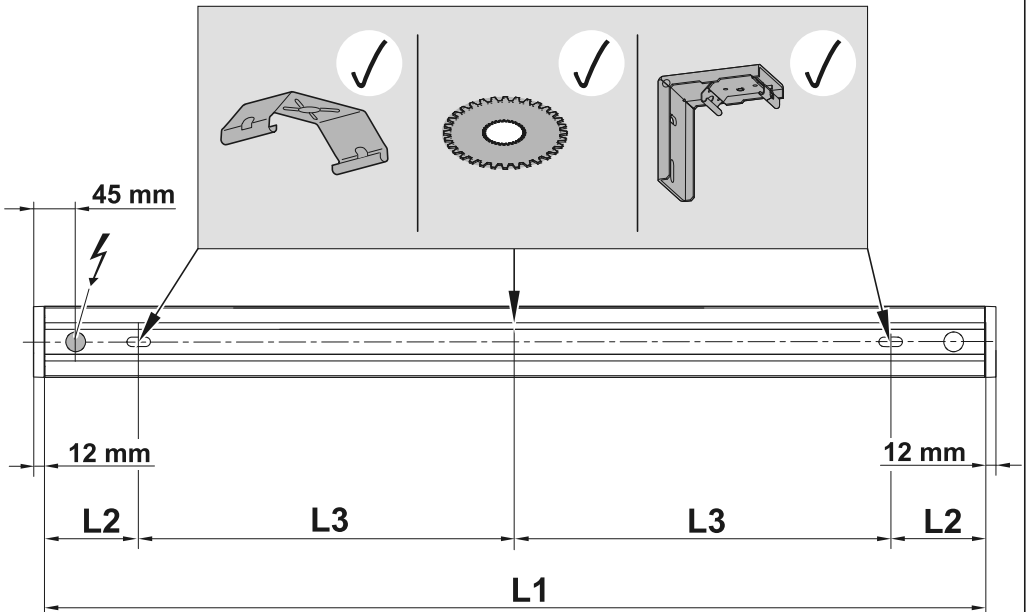

## 2 MOUNTING OPTION: MSP (pendant)

min.



2a

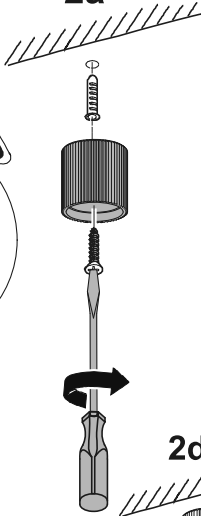

2b

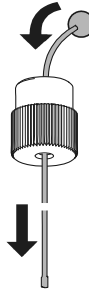

TX20

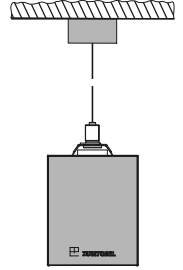

2c

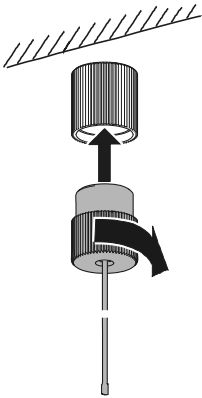

2d

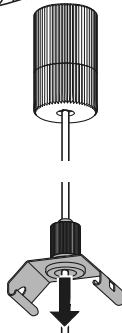

max. 30 kg

2e

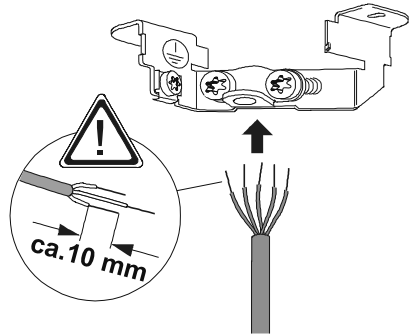

2f

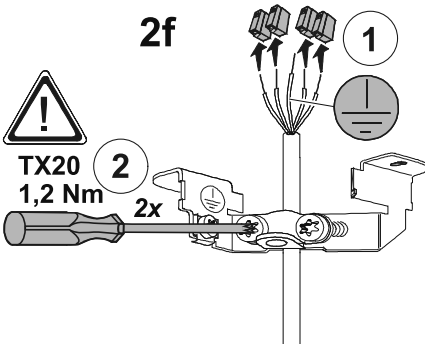

2g

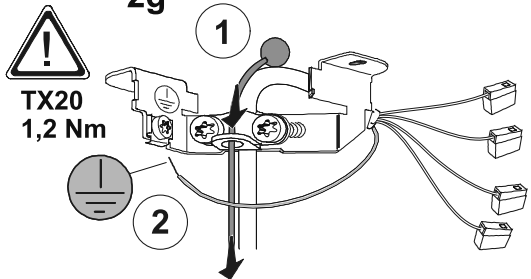

...

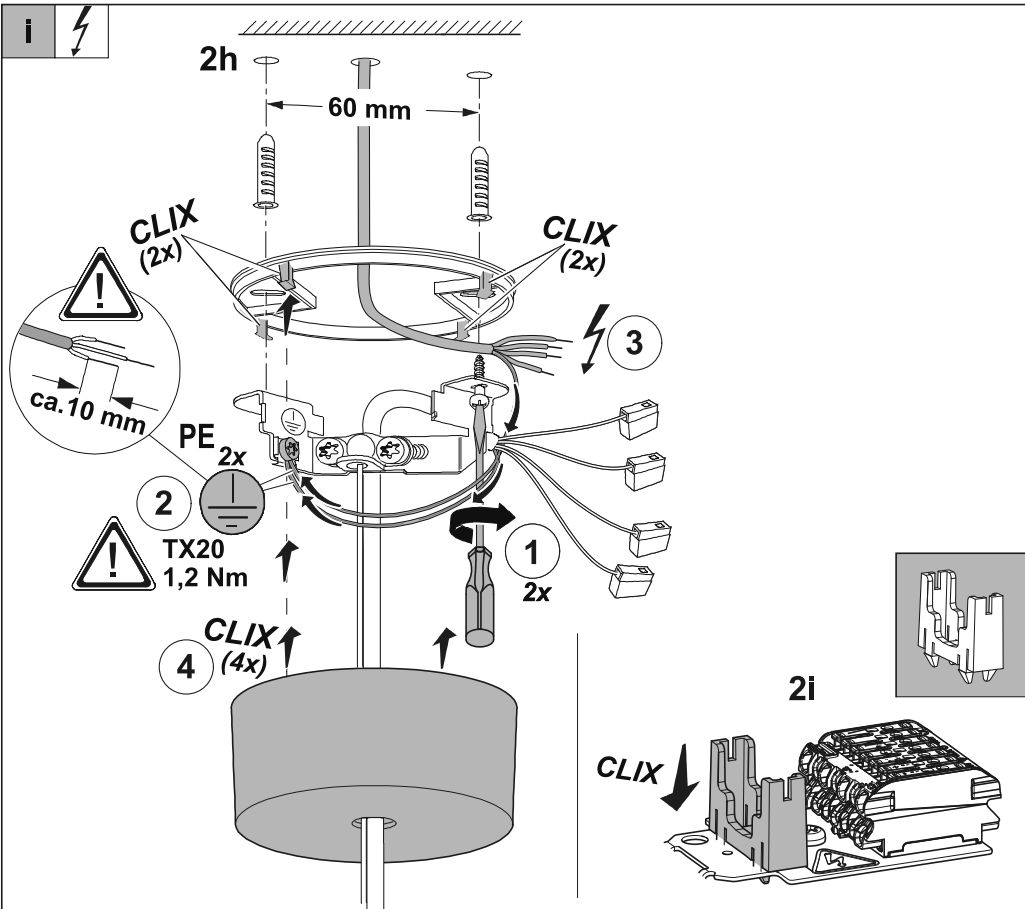

**2 MOUNTING OPTION: MWS (ball proof)**

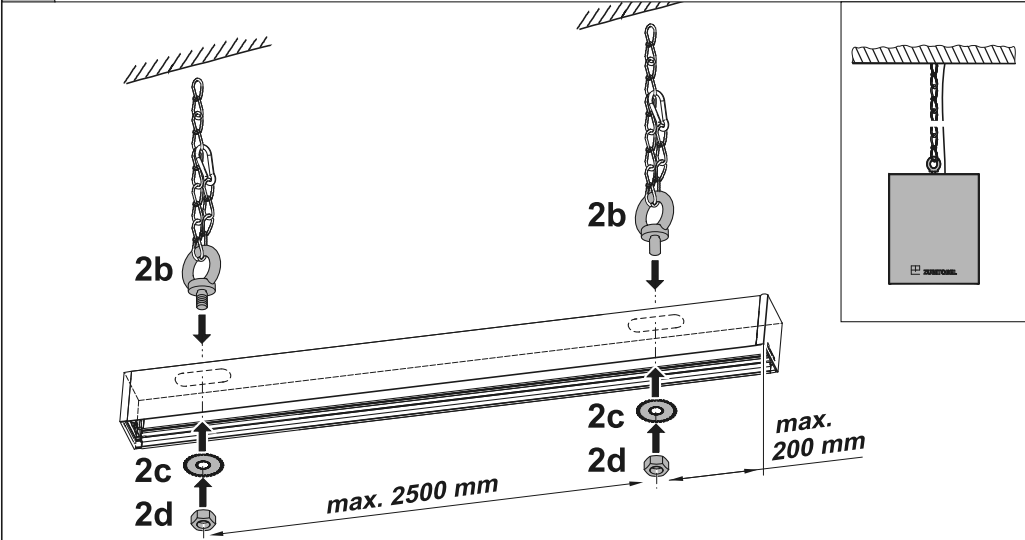



### 3 MOUNTING OPTION: MSC (surface-mounted) / MSP (pendant)

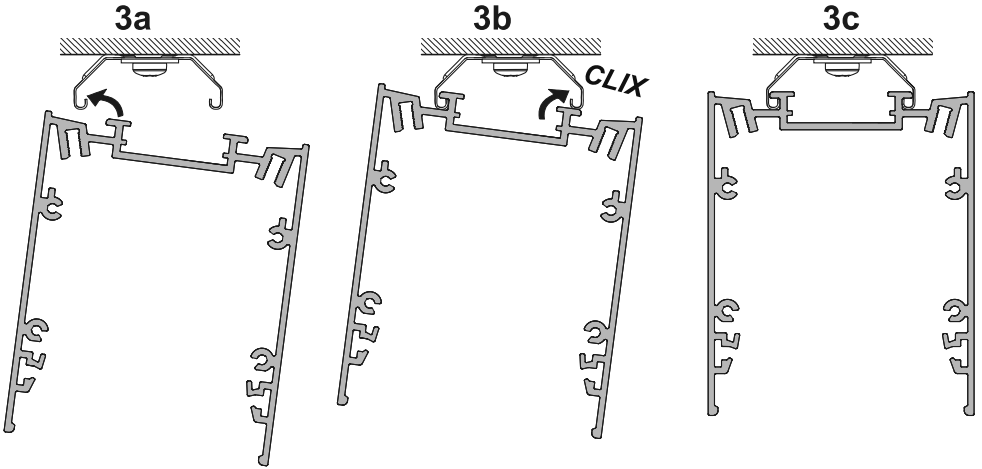
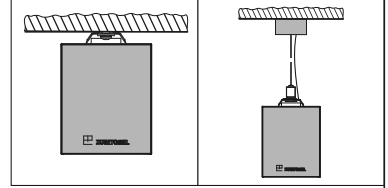

### 3 MOUNTING OPTION: MSW (wall-mounting)

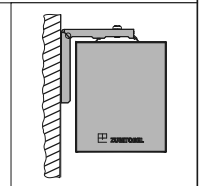
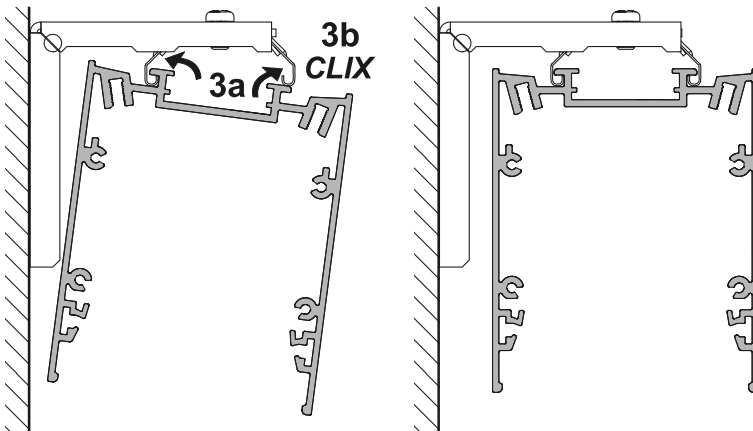

# i MOUNTING OPTION: CORNER

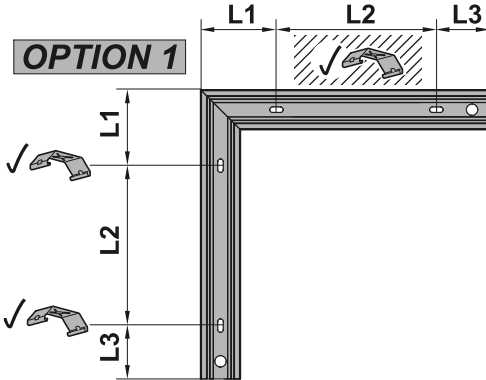
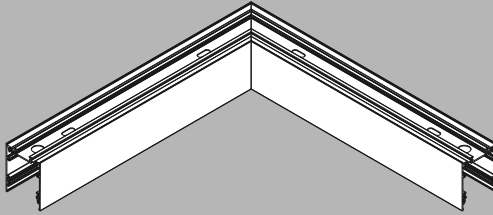

(dimensions in mm)			
type	L1	L2	L3
L543	143	300	100
L793	143	550	100

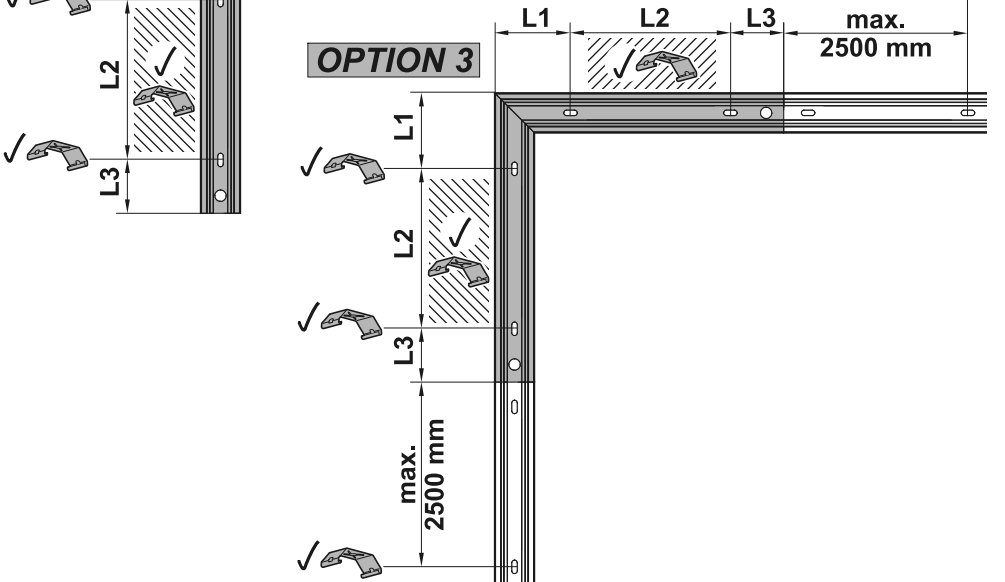
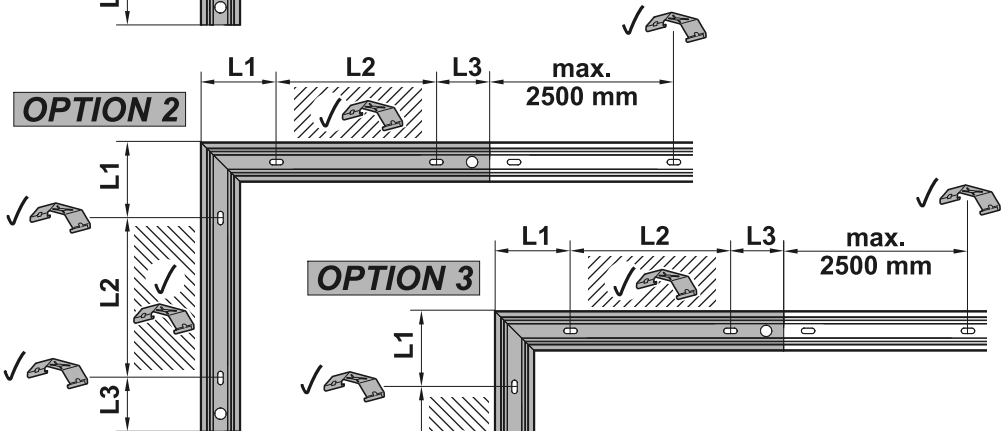

**i MOUNTING OPTION: X - CORNER (dimensions in mm)**

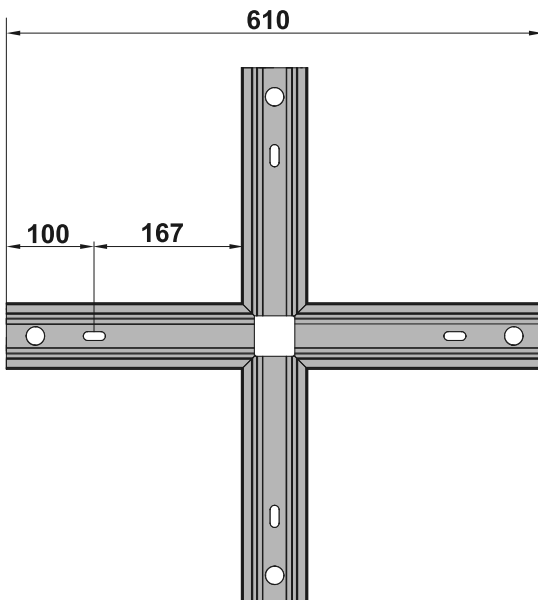
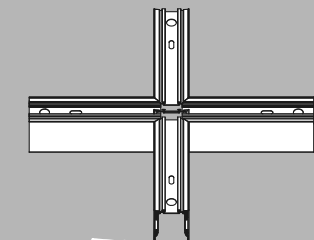

**i MOUNTING OPTION: T - CORNER (dimensions in mm)**

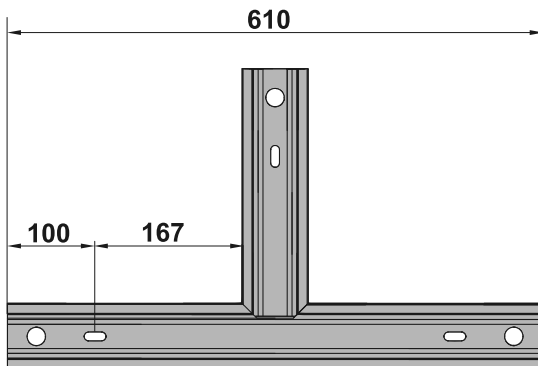
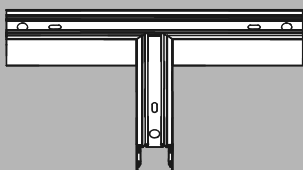

## 4 LB (continuous row luminaires ONLY)

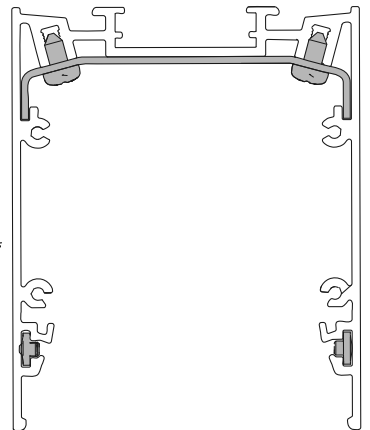
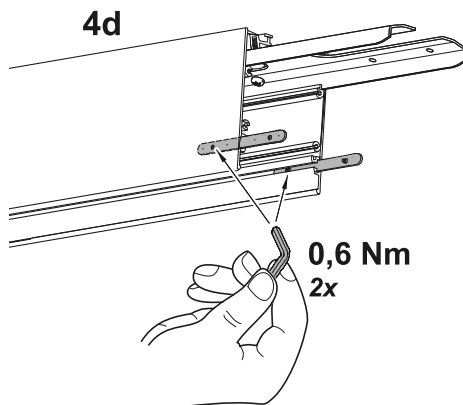
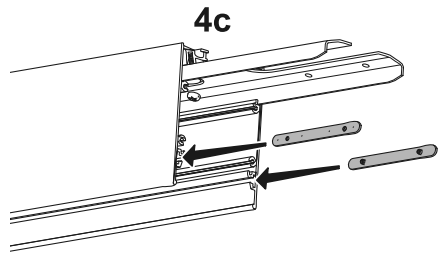
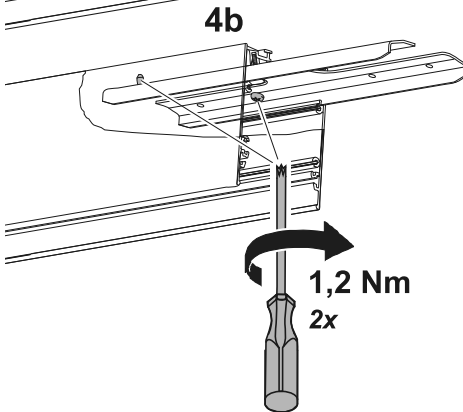
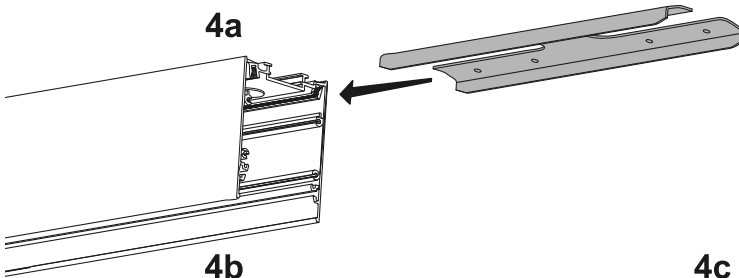
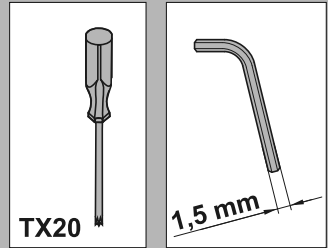
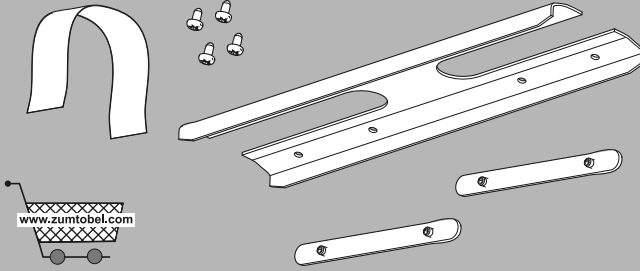

min.



4f

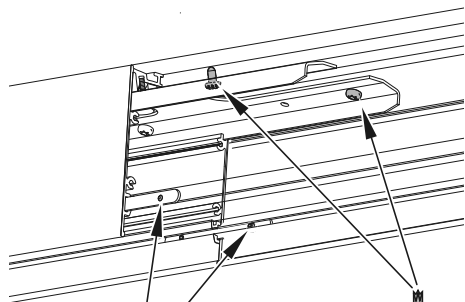
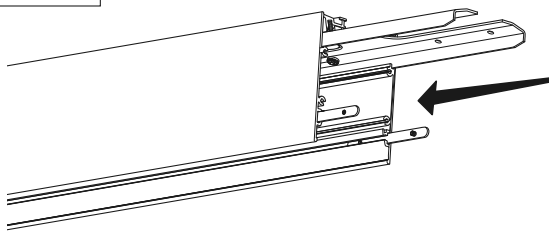

4g

0,6 Nm  
2x

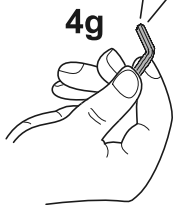

4h

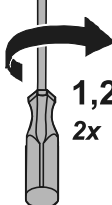

1,2 Nm  
2x

4i

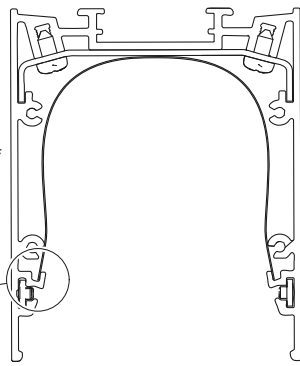
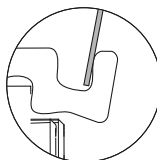
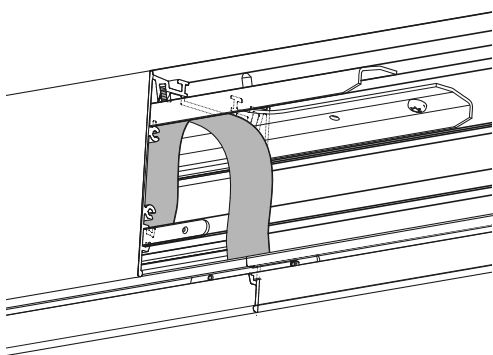
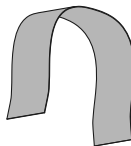

4j

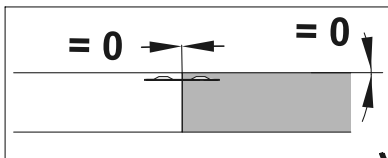
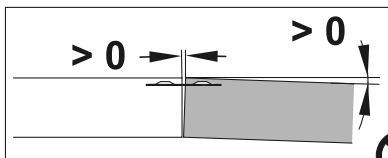

# (4) MOUNTING OPTION: IP54 CON SET

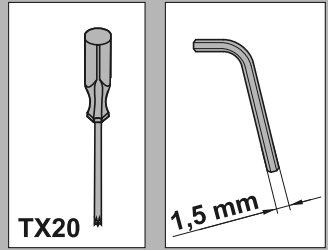
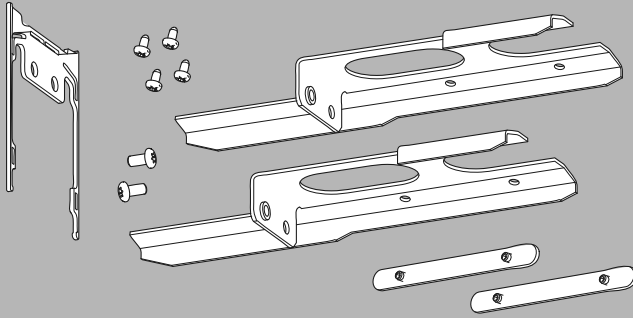

(4a)

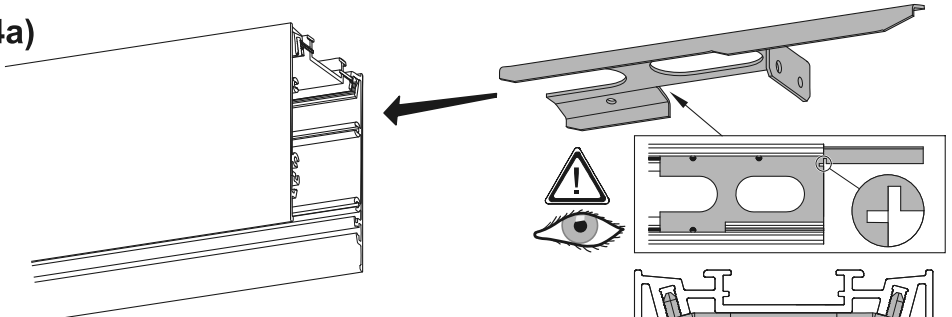

(4b)

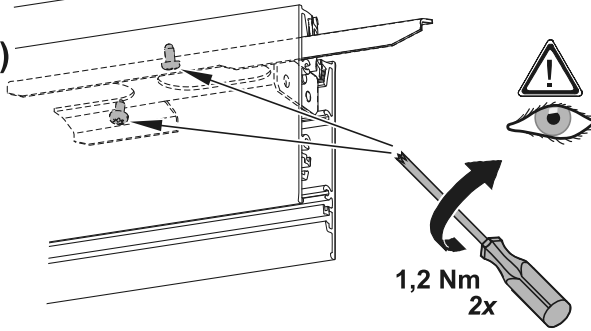

(4c)

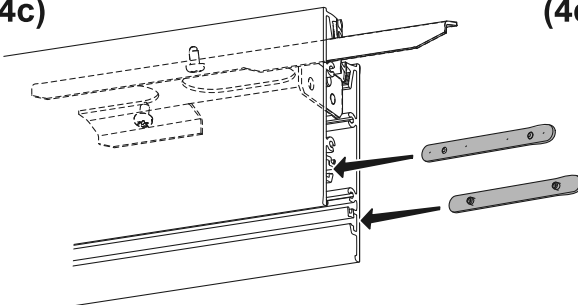

(4d)

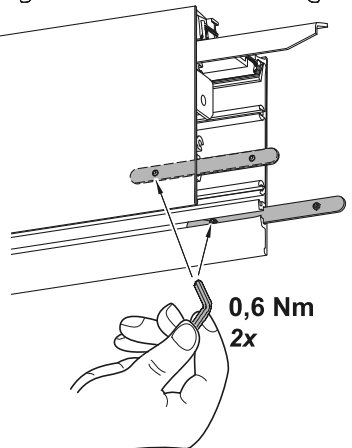

(4e)

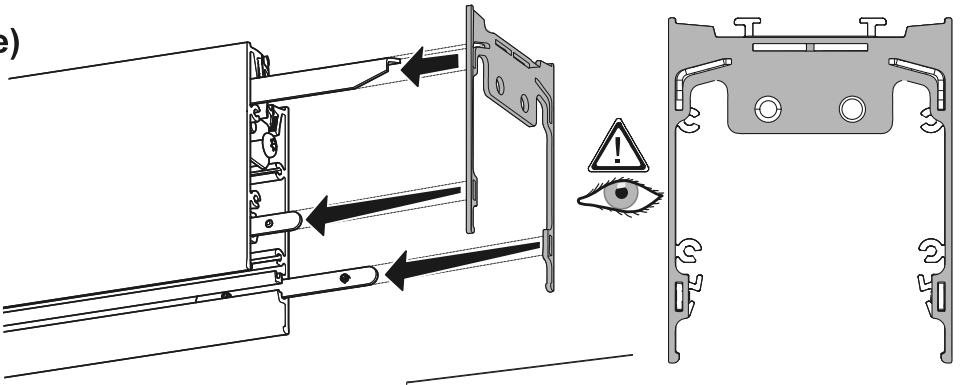

(4f)

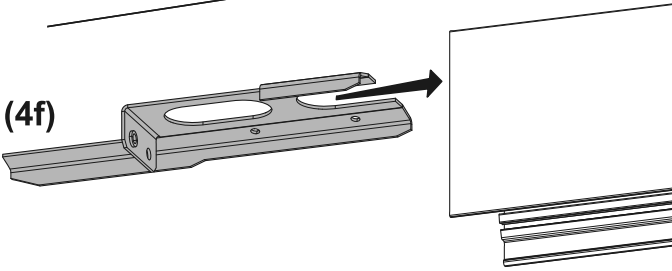

(4g)

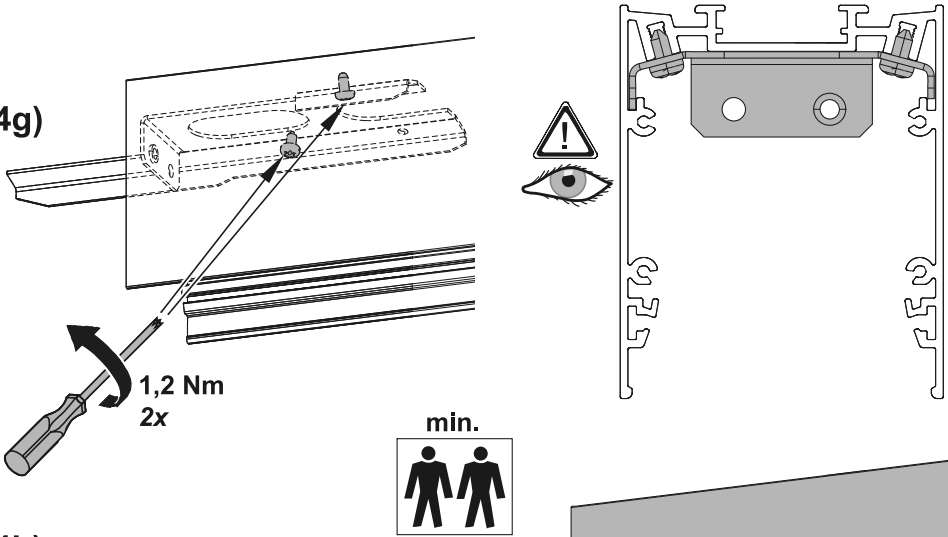

(4h)

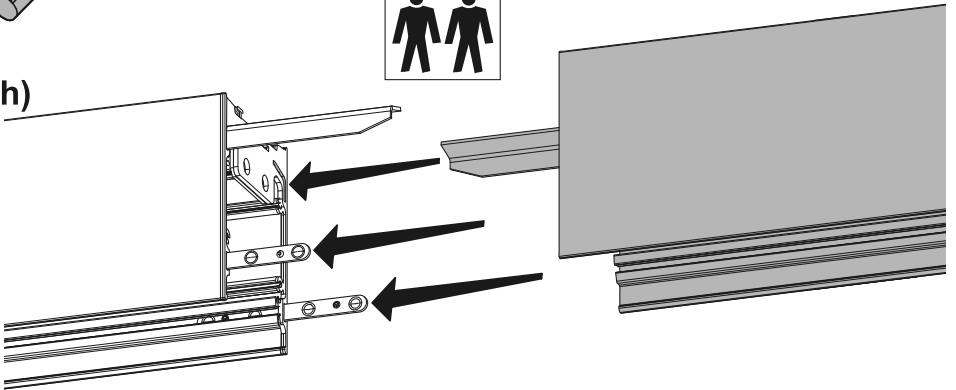

(4i)

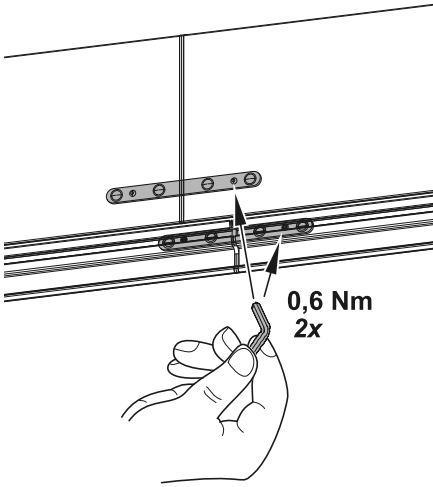

(4j)

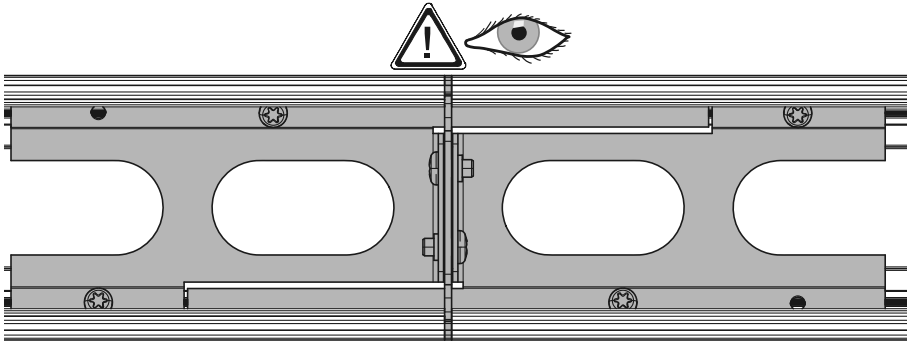
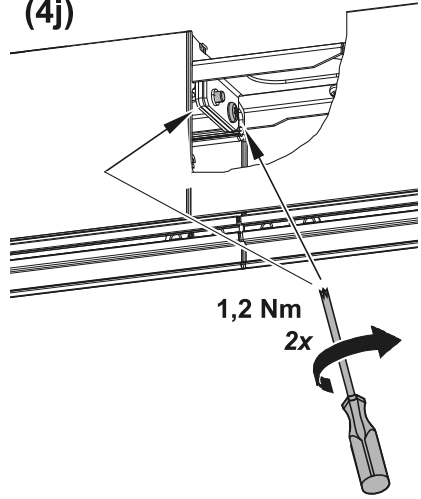

(4k)

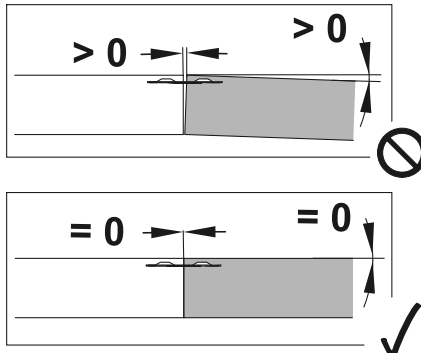



5

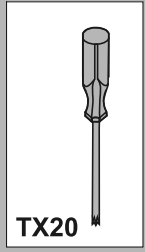
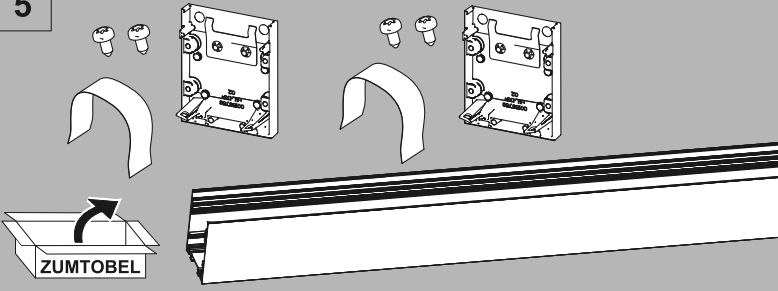

TX20

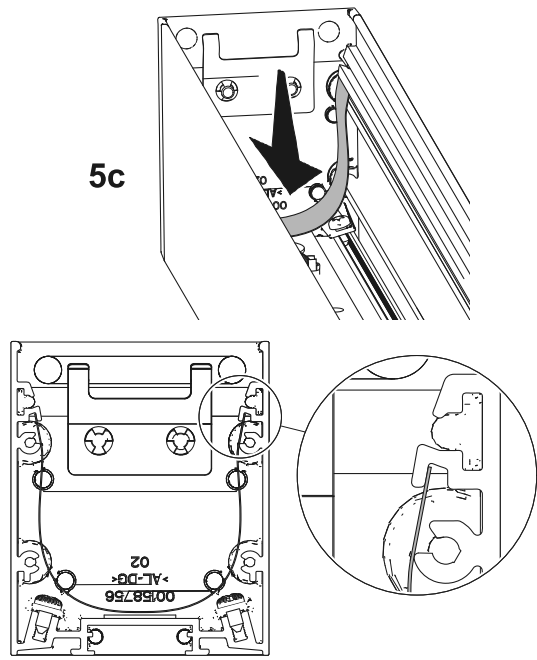
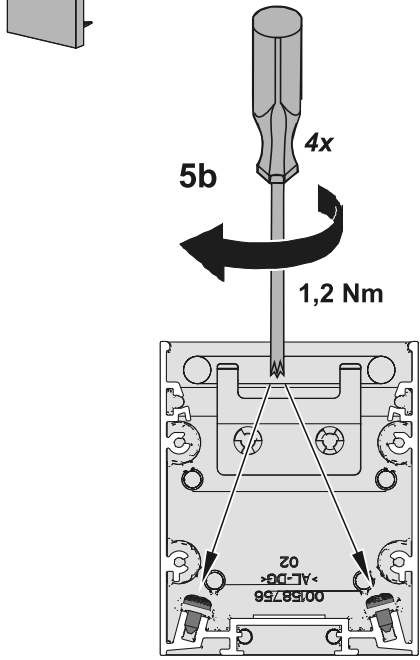
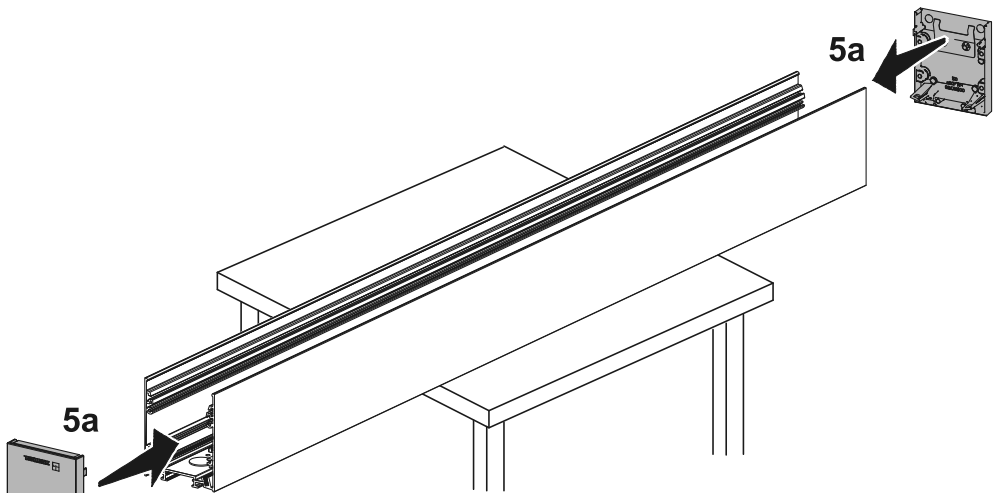

# (5) MOUNTING OPTION: IP54 EC SET

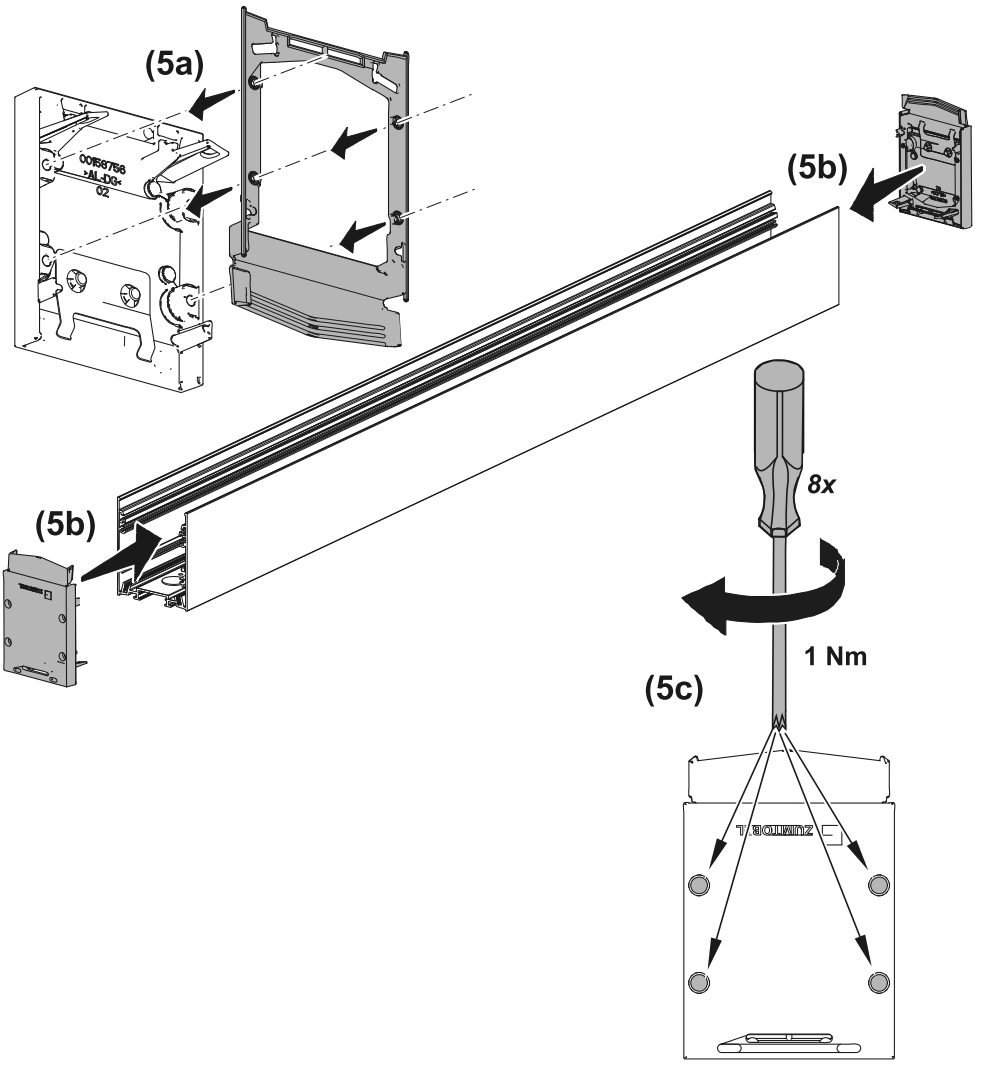
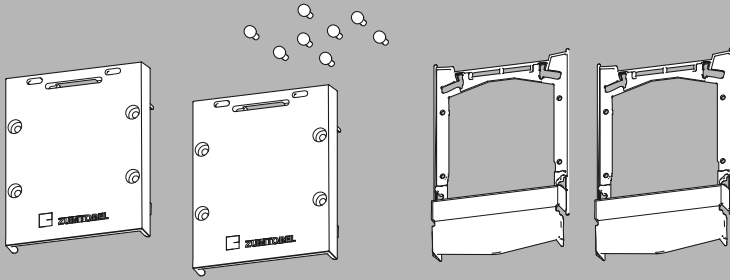

# (5) MOUNTING OPTION: BWS EC SET

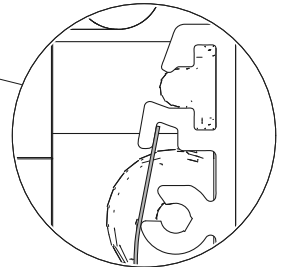
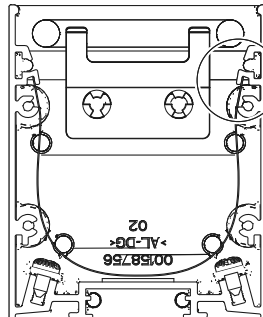
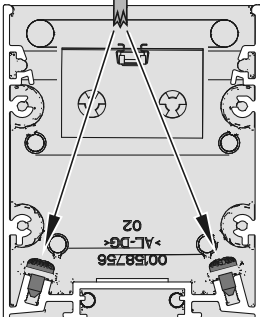
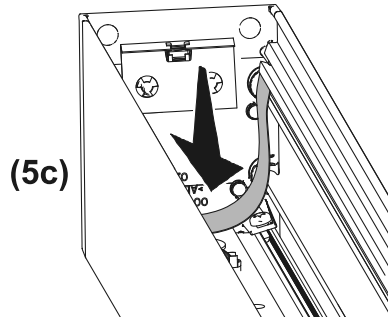
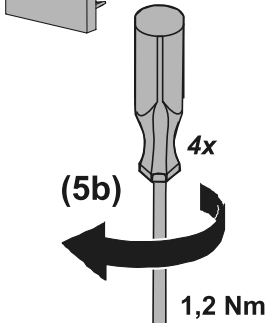
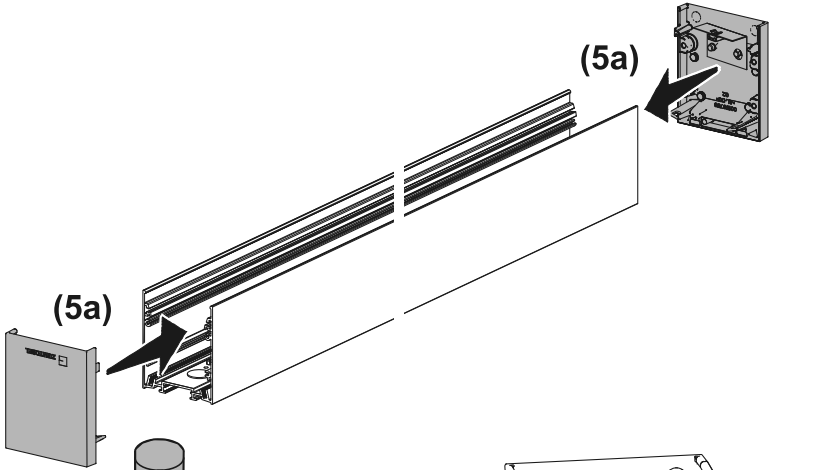
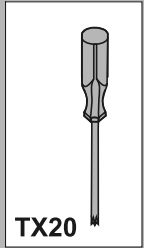
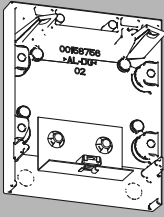

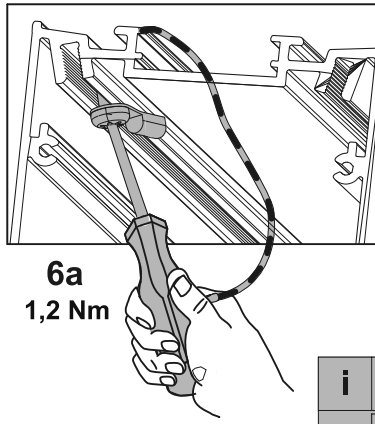
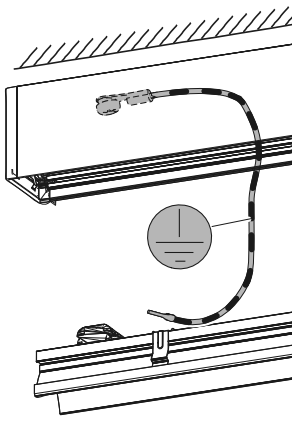

6a  
1,2 Nm

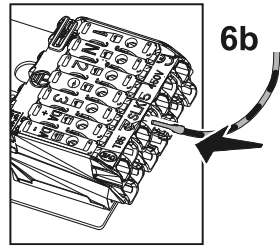

6b

**i** **OPTION MSP**

 **page 25**

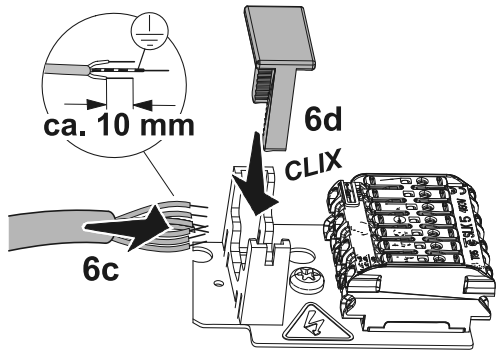
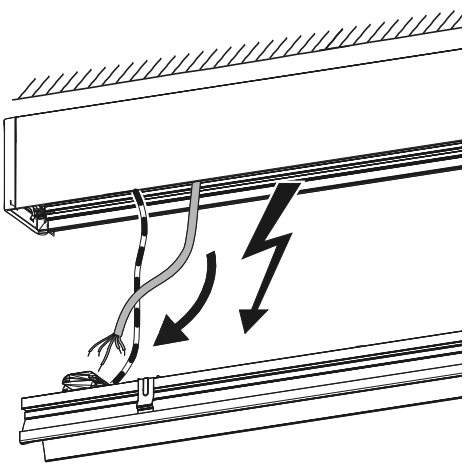

ca. 10 mm

6d  
CLIX

6c

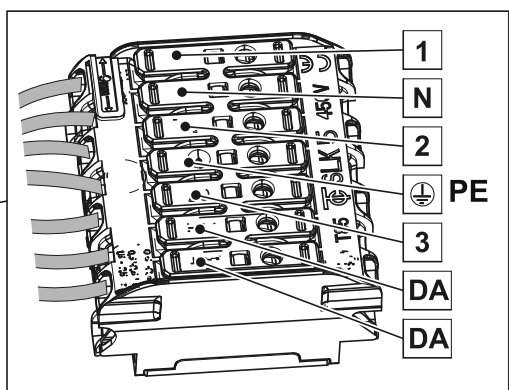
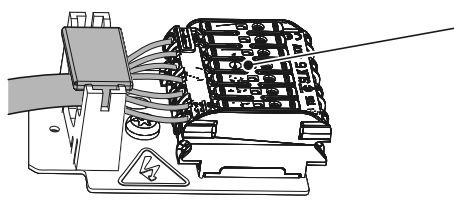

- 1
- N
- 2
- PE
- 3
- DA
- DA

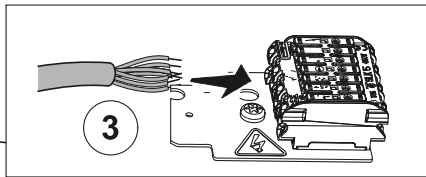
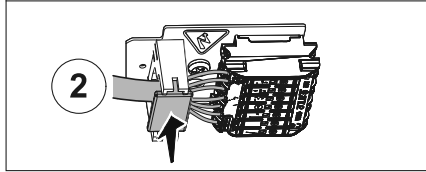
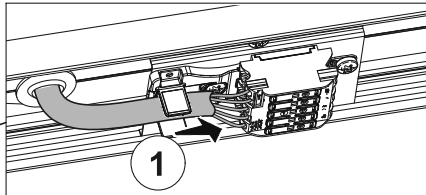
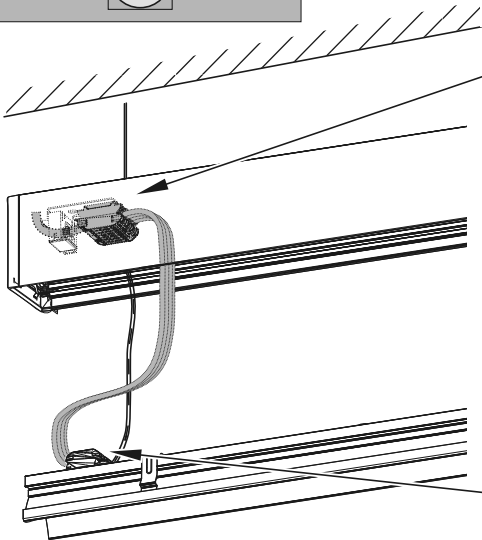

## 7 LB (continuous row luminaires ONLY)



1,5 mm<sup>2</sup> max. 10 A

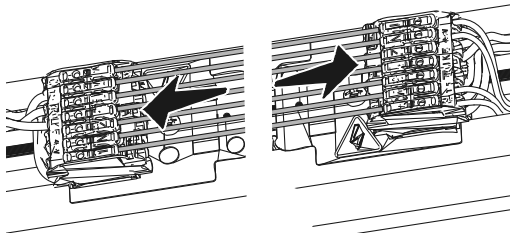
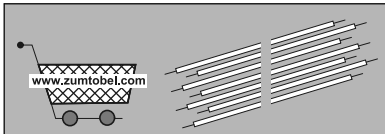
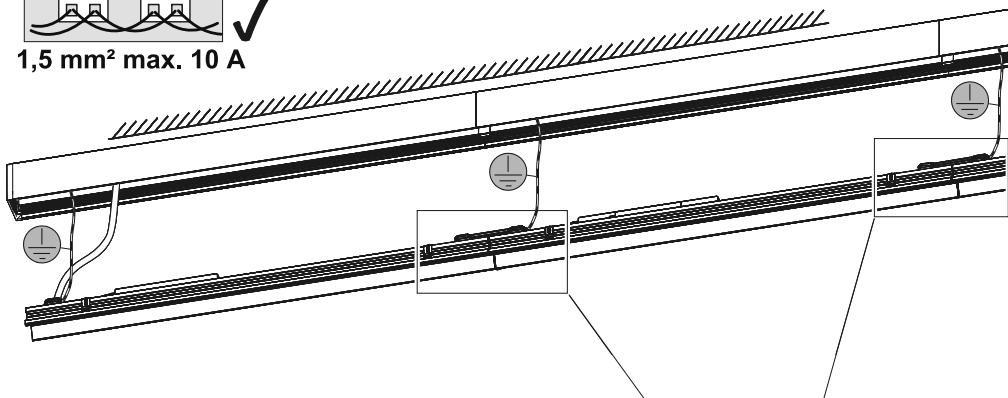

# 8 LB (continuous row luminaires ONLY)

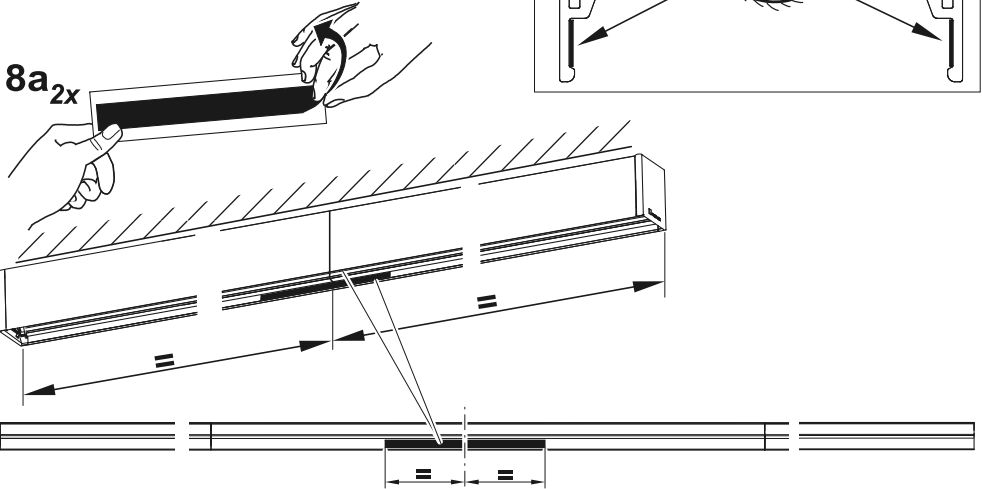
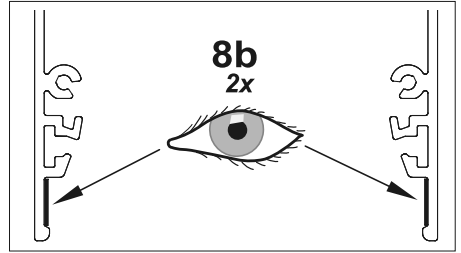
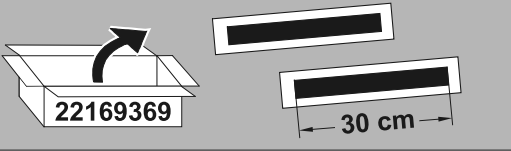

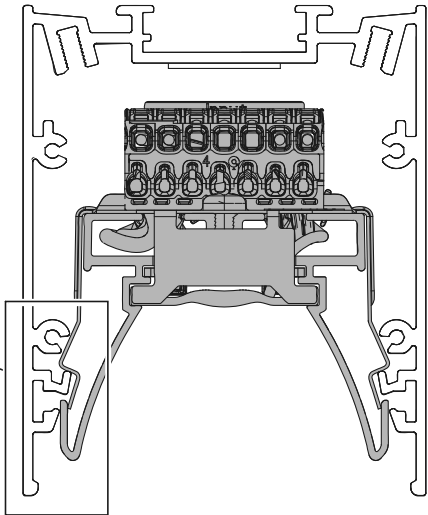
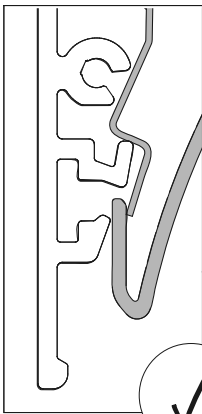
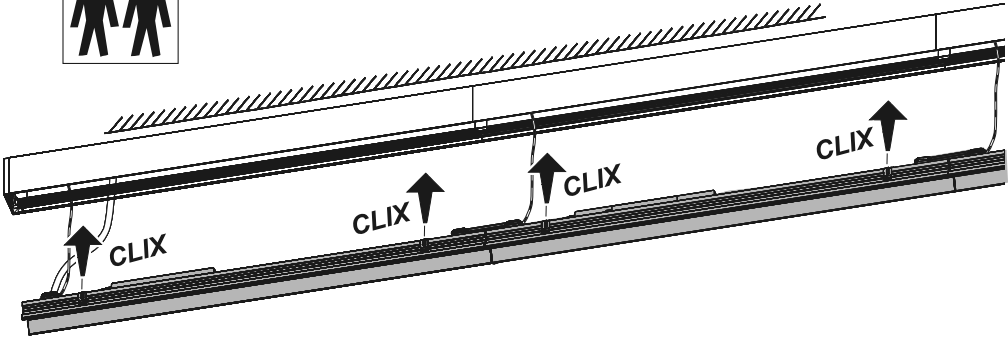
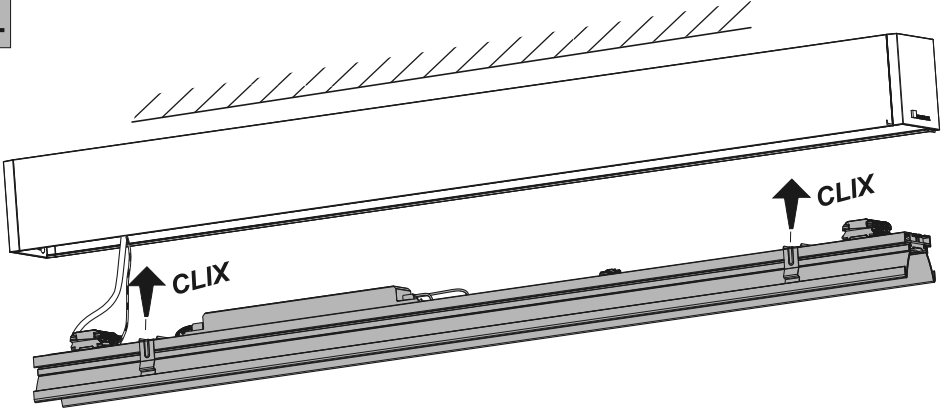

(9) MOUNTING OPTION: MC (minicell)

SL

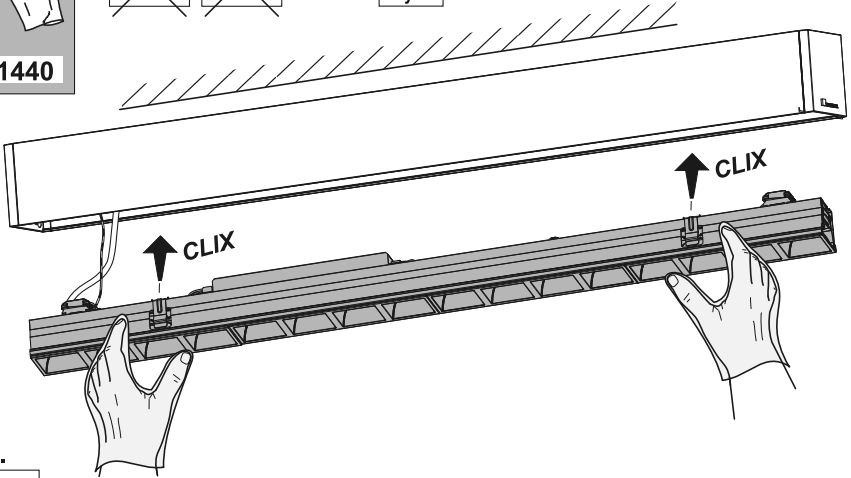

LB

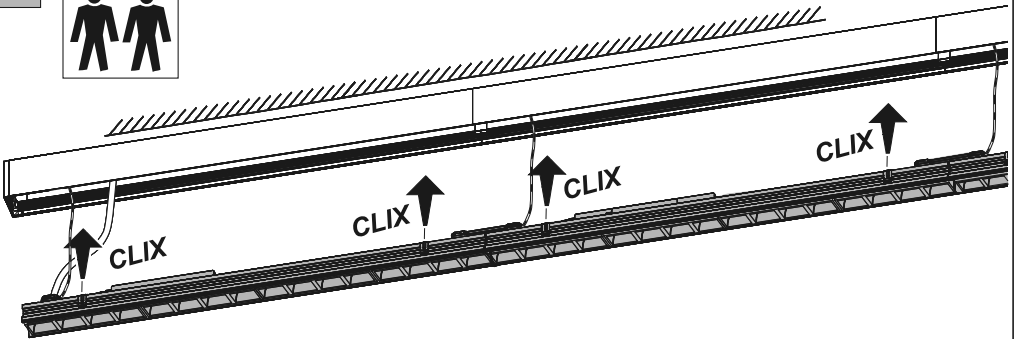

i

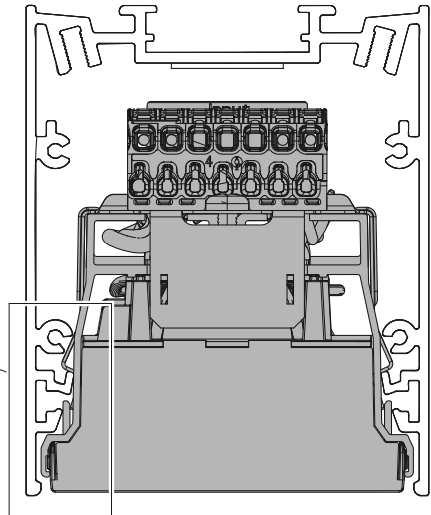
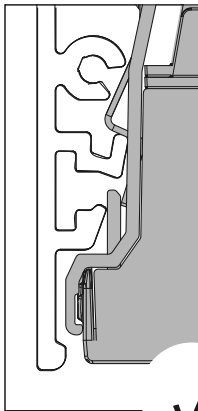



# (10) OPTIC OPTION: wallwasher ONLY

~~IP54~~ Ⓞ

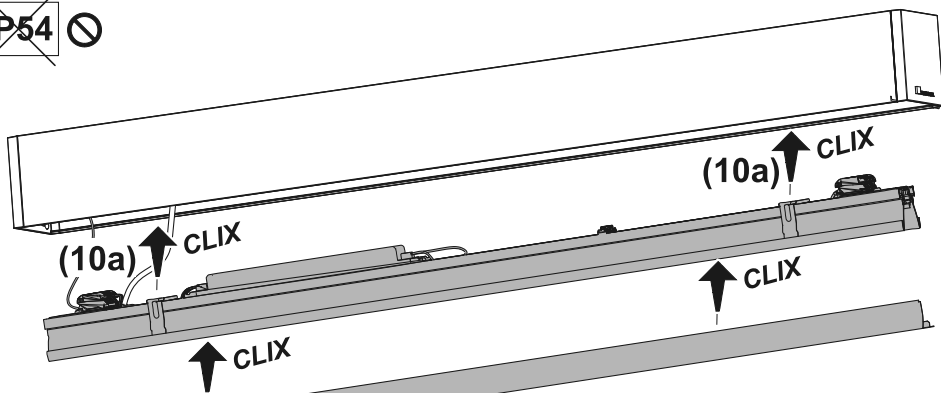

(10b)

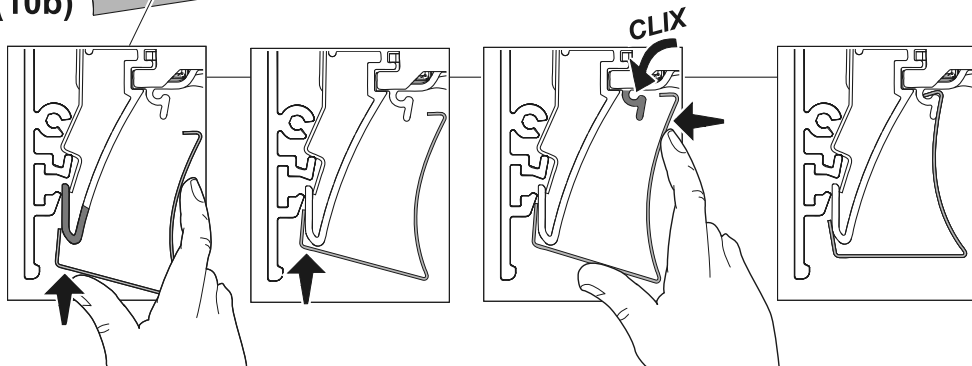

## i DISMOUNTING

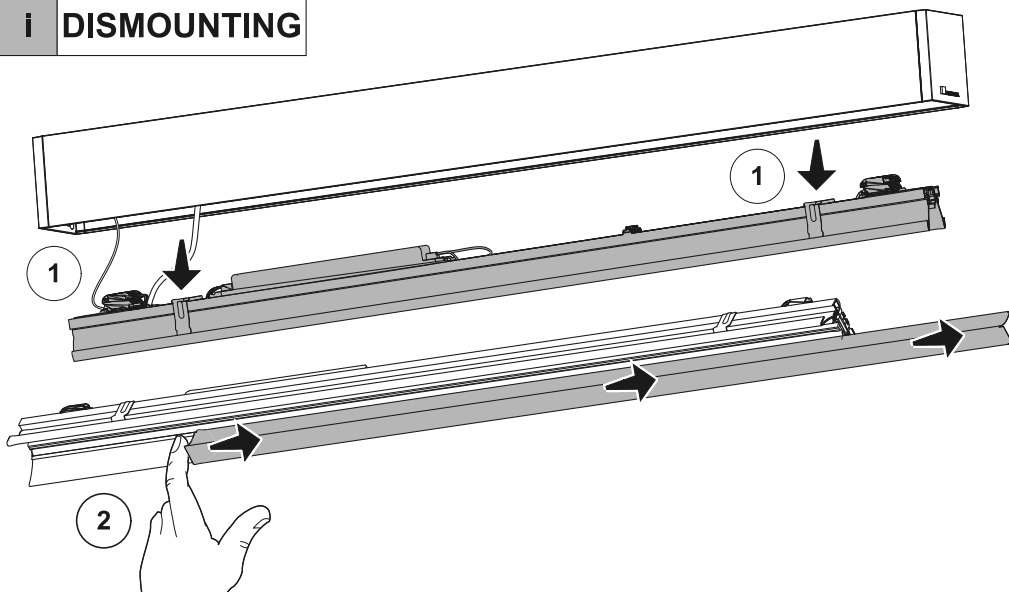

11  
SL



11a

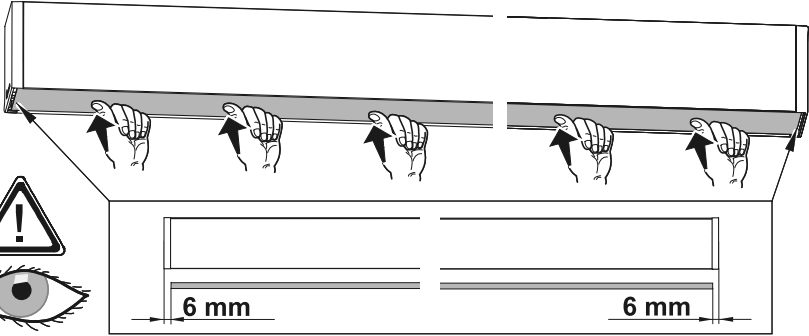

LB

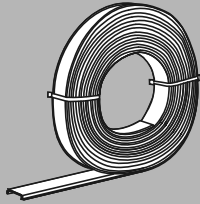
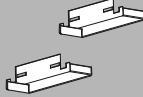

11a

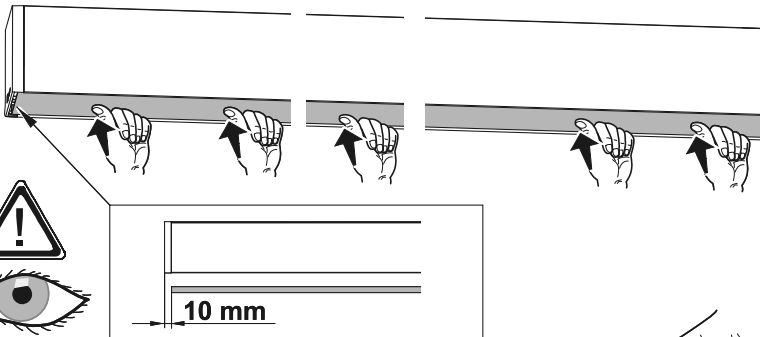

11b

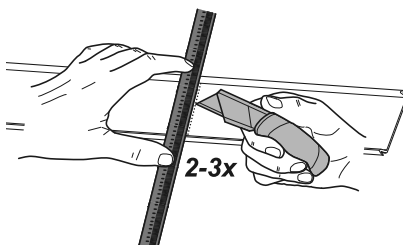

11c

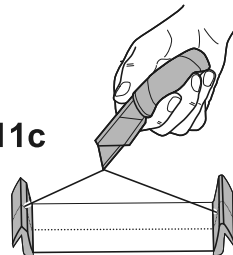

11d

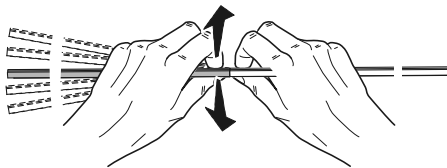

(11e)

PCO ONLY

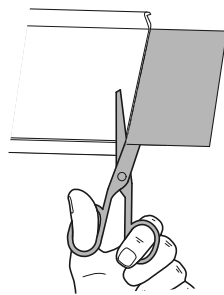

11f

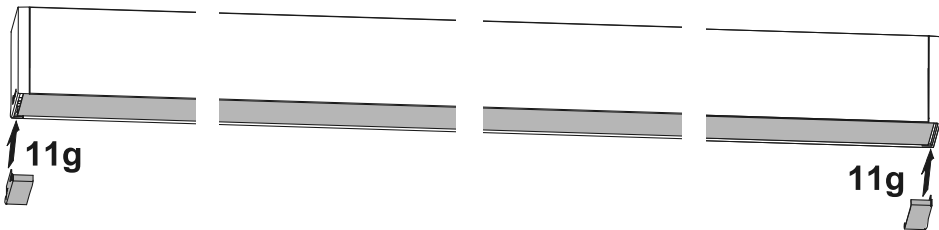
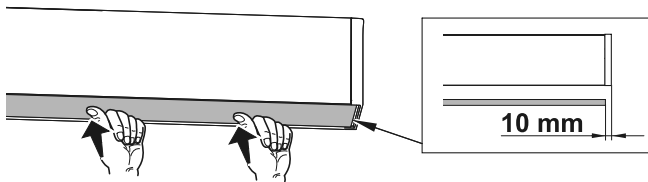

### (11) MOUNTING OPTION: CORNER

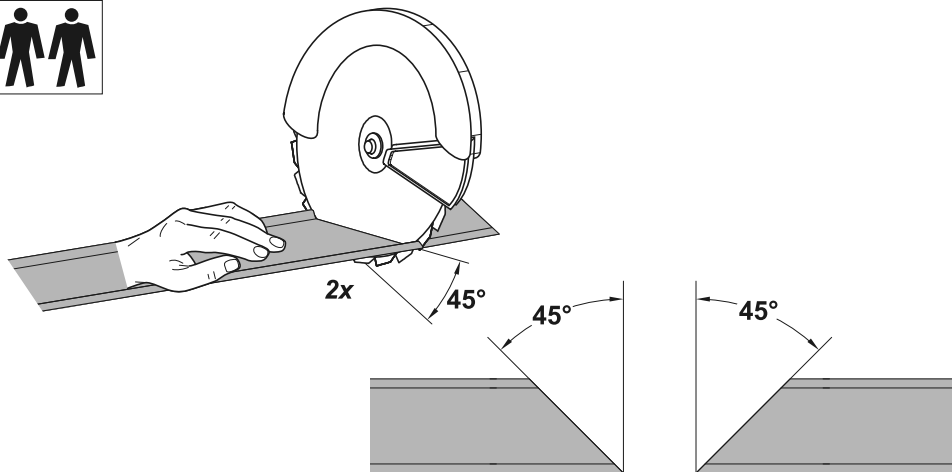
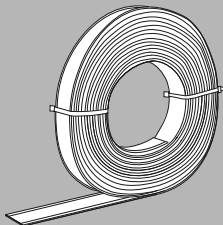

**(11) SL LB MOUNTING OPTION: mask plate (IP54)**

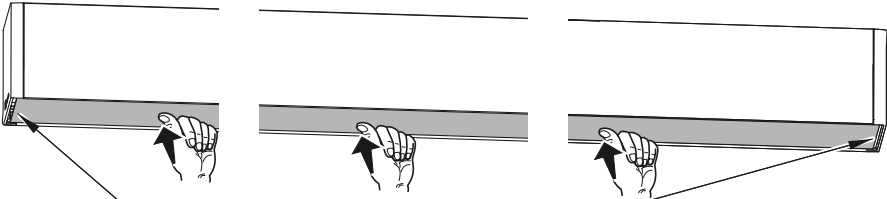
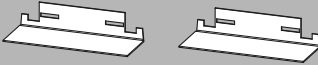

**(11a)**

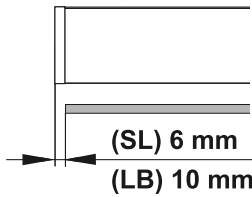

**(11b)**

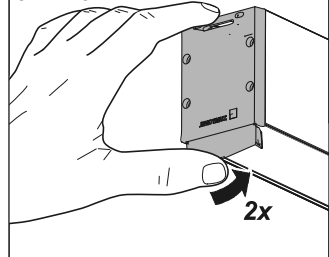

**(11c)**

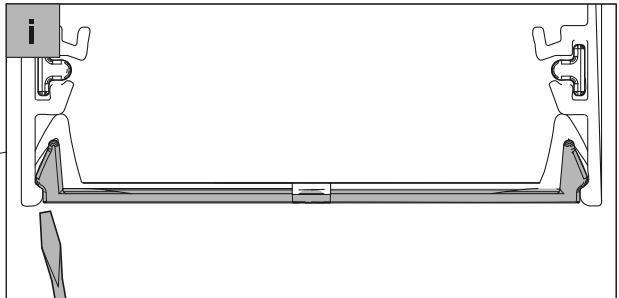
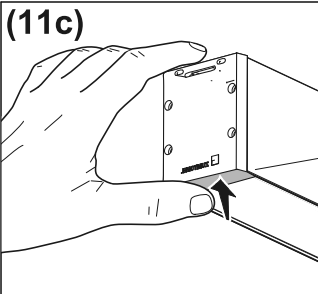

**OPTION**



**(11d)**

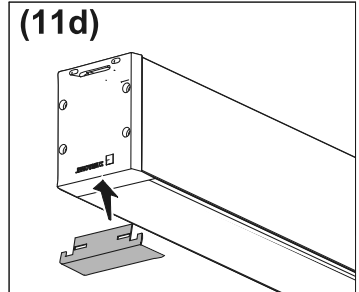

**(11) SL LB MOUNTING OPTION: mask plate (BWS)**

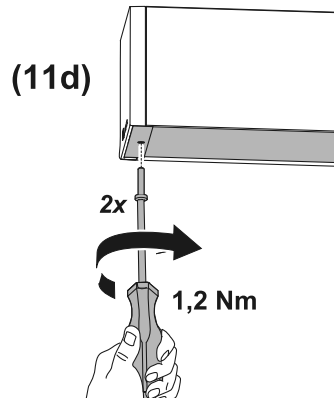
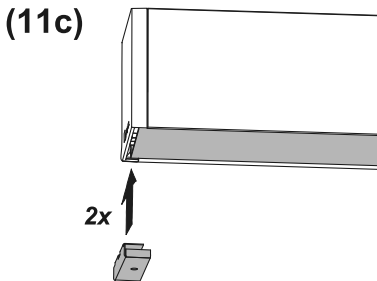
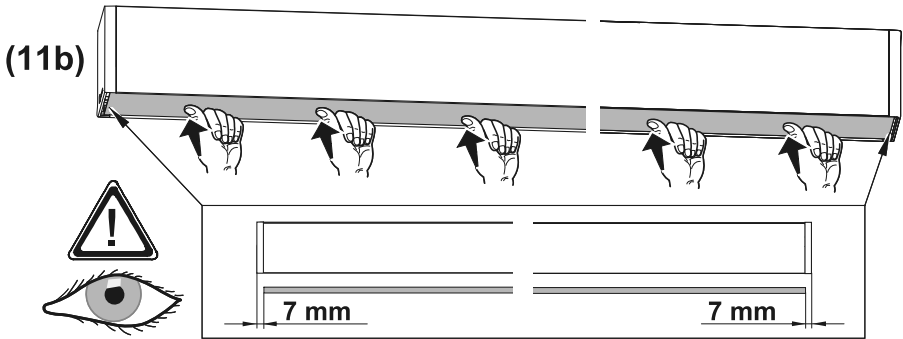
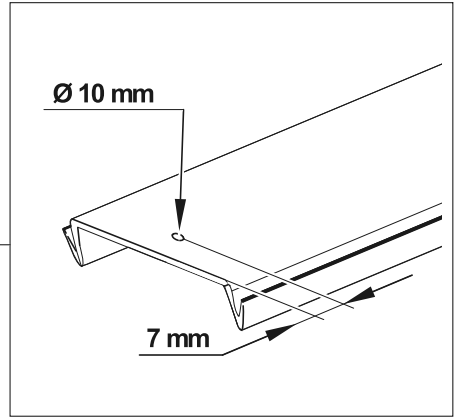
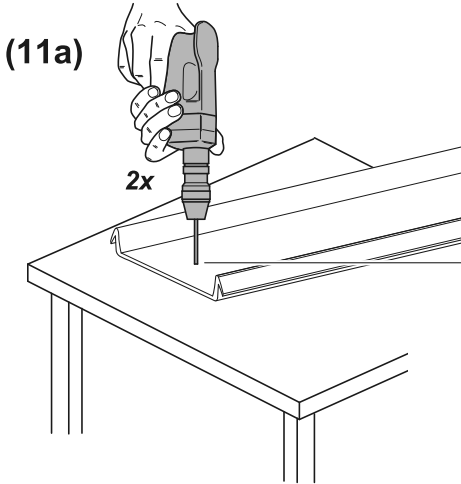
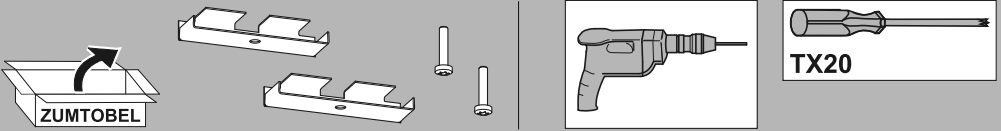

(11) SL LB MOUNTING OPTION: DD (drop-diffuser)

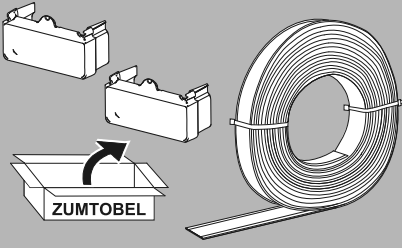

(dimensions in mm)		
L1	L3	L2
< 4024	16	L1 - 2 x L3
> 4024	22	L1 - 2 x L3

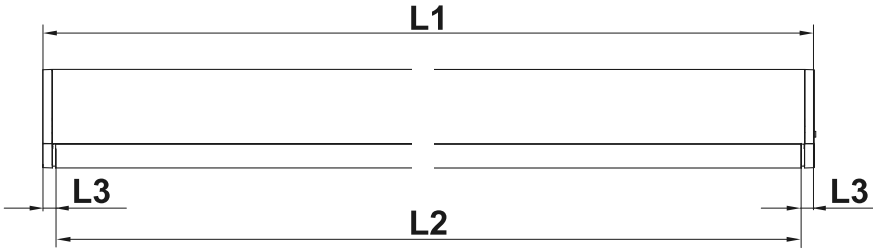

10a

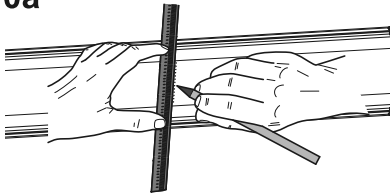

10b

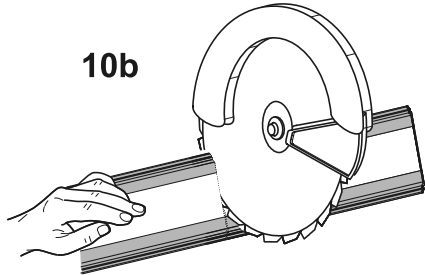

10c

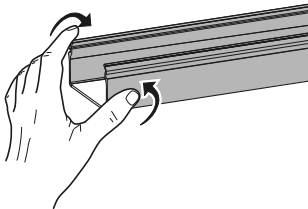

10d

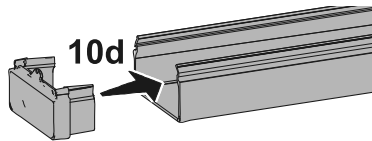

10e

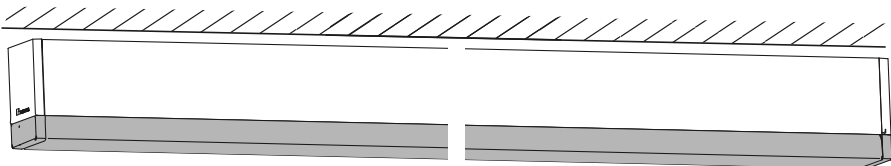
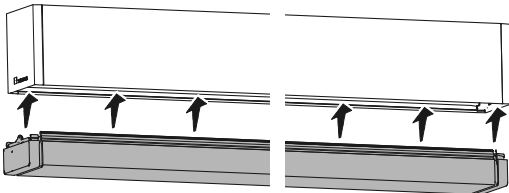

## **DE** Hinweise für die Montage, die Installation und den Betrieb!

Die Montage und Inbetriebnahme der Leuchte sowie jede Veränderung an der Leuchte darf nur von autorisierten Fachkräften (qualifizierter Elektriker) durchgeführt werden. Die Leuchte dient ausschließlich der Beleuchtung und ist entsprechend den nationalen Errichtungsbestimmungen zu installieren. Achtung! Während der Verdrahtung und Installation der Leuchten und Versorgungsgeräte immer spannungslos arbeiten. Nichtbeachtung kann zur Zerstörung der LED-Module führen. Hot Plug-In ist verboten. Hot Plug-In kann zu Schäden an der Leuchte und zum Verlust der Garantie führen! Der Hersteller haftet nicht für Schäden, die aus fehlerhafter Montage, aus unsachgemäßem Betrieb oder unautorisierten Veränderungen an der Leuchte resultieren. Die Lichtquelle dieser Leuchte darf nur vom Hersteller oder einem von ihm beauftragten Servicetechniker oder einer vergleichbar qualifizierten Person ausgetauscht werden. **Vorsicht, Gefahr eines elektrischen Schlags!**



## **EN** Instructions for assembly, installation and operation!

The installation and commissioning of the luminaire as well as any modification to the luminaire may only be performed by authorized personnel (qualified electrician). The luminaire is used exclusively for lighting and is to be installed in accordance with the national installation regulations. Caution! Make sure that the luminaires and power supply units are always disconnected from the mains supply during wiring and installation work. Otherwise, the LED modules may be destroyed. Hot plug-in is not permitted. Hot plug-in may result in damage to the luminaire and entail loss of warranty claims! The manufacturer is not liable for damages resulting from improper or faulty installation or operation or from unauthorized modifications to the luminaire. The light source contained in this luminaire shall only be replaced by the manufacturer or his service agent or a similarly qualified person.



**Caution, risk of electric shock!**

## **FR** Instructions pour le montage, l'installation et l'utilisation!

L'installation et la mise en service du luminaire ainsi que toute modification au luminaire doivent être effectuées par un personnel autorisé (électricien qualifié). Le luminaire sert uniquement à l'éclairage et doit être installé conformément aux prescriptions nationales en matière d'installation. Attention! Toujours travailler sans tension lors du câblage et de l'installation des luminaires et unités d'alimentation. Le nonrespect de cette consigne peut entraîner la destruction des modules à LED. Le raccordement en cours de service (hot plug-in) est interdit. Il peut provoquer l'endommagement du luminaire et la perte de la garantie! Le fabricant décline toute responsabilité pour les dommages résultant d'une mauvaise installation ou opération, ou d'une modification non autorisée du luminaire. La source lumineuse de ce luminaire peut uniquement être remplacée par le fabricant, un technicien de service mandaté par lui ou une personne ayant une qualification similaire. **Avertissement, risque de choc électrique!**



## **IT** Istruzioni per il montaggio, l'installazione e il funzionamento!

L'installazione e la messa in servizio degli apparecchi, nonché qualsiasi modifica dell'apparecchio può essere eseguita solo da personale autorizzato (elettricista qualificato). L'apparecchio è destinato esclusivamente all'illuminazione e va installato in conformità alle leggi nazionali in vigore. Attenzione! Lavorare sempre in assenza di tensione mentre si cablano e si installano gli apparecchi e le unità di alimentazione. In caso contrario i moduli LED possono andare distrutti! Hot Plug-In è vietato. L'Hot Plug-In può danneggiare l'apparecchio e comportare la perdita della garanzia! Il produttore non si assume alcuna responsabilità per i danni derivanti da un'installazione impropria o difettosa, o per modifiche non autorizzate apportate all'apparecchio. La sorgente luminosa contenuta in questo apparecchio può essere sostituita solo dal produttore o da un centro assistenza autorizzato o da una persona qualificata. **Attenzione, pericolo di scarica elettrica!**



## **ES** Instrucciones de montaje, instalación y funcionamiento!

El montaje y la puesta en servicio de la luminaria así como toda modificación de la luminaria deberán ser realizados exclusivamente por personal técnico autorizado (electricista certificado). La lámpara está destinada exclusivamente a la iluminación y debe ser instalada de acuerdo con las pertinentes normas nacionales. Atención! Siempre mantenga desconectada la tensión al realizar las tareas de cableado y de instalación de las luminarias y dispositivos de alimentación. De lo contrario podría destruirse el módulo LED. Hot plug-in no es una opción y puede causar daños a la lámpara o luminaria! La conexión en caliente puede dañar la luminaria e invalidar la garantía! El fabricante no se responsabiliza por los daños derivados del montaje incorrecto u operación indebida de la luminaria así como de las modificaciones no autorizadas en la luminaria. El reemplazo de la fuente de luz de la luminaria deberá ser realizado exclusivamente por el fabricante o por un técnico de servicio designado por este o bien por una persona con una certificación equivalente. **Precaución: peligro de descarga eléctrica!**



## **NL** Instructies voor montage, installatie en gebruik!

De montage en inbedrijfstelling van de armatuur en eventuele wijzigingen aan de armatuur mogen uitsluitend door geautoriseerde vaklui (gekwalificeerde elektriciens) worden uitgevoerd. De lamp dient uitsluitend voor de verlichting en dient conform de nationale bouwbeoordelingen te worden geïnstalleerd. **Opgelet!** Tijdens het bedraden en installeren van de armaturen en voedingsapparaten altijd zonder spanning werken. Bij niet-naleving hiervan kunnen de LEDmodules ernstig worden beschadigd. 'Hot plug-in' is verboden. Dit kan leiden tot schade aan de armatuur en verlies van de garantie. De fabrikant is niet aansprakelijk voor schade als gevolg van onjuiste foutieve installatie bediening of schade welke het gevolg is van niet geautoriseerde wijzigingen aan het armatuur. De lichtbron in de armatuur mag enkel door de fabrikant, een erkende servicevertegenwoordiger of een gelijkwaardig gekwalificeerd persoon vervangen worden. **Opgelet! Gevaar voor een elektrische schok!**



## **SV** Instruktioner för montering, installation och användning!

Installation och drifttagning av armaturen samt all annan modifiering av armaturen får endast utföras av kvalificerad personal (behörig elektriker). Armaturen är uteslutande avsedd för belysning och ska installeras i enlighet med de nationella installationsbestämmelserna. Varning! Se till att armaturerna och strömförsörjningsenheterna alltid är fränkopplade från elnätet under ledningsdragnings och installation. I annat fall kan LED-modulerna förstöras. Hot plug-in är förbjudet. Hot plug-in kan skada armaturen och leda till att garantin upphör att gälla! Tillverkaren ansvarar inte för skador som uppkommer på grund av felaktig installation, felaktig användning eller obehöriga modifieringar på armaturen. Byte av ljuskälla på denna armatur får endast utföras av tillverkaren eller en servicetekniker som godkänts av honom eller en person med jämförbara kvalifikationer. **Varning, risk för elektriska stötar!**



## **FI** Kokoonpano-, asennus- ja käyttöohjeet!!

Vain valtuutettu ammattihenkilö (koulutettu sähkömiehes) saa suorittaa valaisimen asennuksen ja käyttöönoton tai muutoksia valaisimessa (pätevä sähköasentaja). Valaisin on tarkoitettu ainoastaan valaistuskäyttöön, ja se on asennettava kansallisten määräysten mukaan. Varoitus! Valaisimien ja syöttölaitteiden kytkemisen ja asentamisen aikana on aina työskennettävä jännitteettömästi. Muutoin LED-moduulit voivat tuhoutua. Hot plug-in ei ole sallittu. Kuumakytkenä voi vahingoittaa valaisinta ja johtaa takuuvaatimusten menettämiseen! Valmistaja ei vastaa vahingoista, jotka johtuvat vääränlaisesta tai virheellisestä asennuksesta tai käytöstä tai valaisimeen tehdyistä luvattomista muutoksista. Vain valmistaja tai sen valtuuttama huoltoteknikko tai vastaavasti koulutettu henkilö saa vaihtaa valaisimen polttimon. **Varoitus, sähköiskun vaara!**



## **RU** Инструкции по сборке, установке и эксплуатации!

Монтаж и ввод в эксплуатацию, а также любое изменение конструкции лампы может осуществляться только уполномоченными специалистами (квалифицированным электриком). Лампа предназначена исключительно для освещения и должна быть установлена в соответствии с национальными инструкциями по установке. Внимание! Следите за тем, чтобы светильники и блоки питания всегда были отключены от сети во время электромонтажных работ. В противном случае светодиодные модули могут быть повреждены. «Горячее» подключение плагинов не допускается. «Горячее» подключение плагинов может привести к повреждению лампы и потере гарантии! Производитель не несет ответственности за повреждения, возникшие в результате неправильной сборки, ненадлежащей эксплуатации или несогласованного изменения конструкции лампы. Замена источника света в этой лампе может осуществляться только производителем, уполномоченным им специалистом по сервисному обслуживанию, или лицом, имеющим соответствующую квалификацию. **Осторожно, опасность электрического удара!**



## **PL** Instrukcja montażu, instalacji i obsługi!

Montaż i uruchomienie oprawy oraz wszelkie zmiany w oprawie mogą być wykonywane wyłącznie przez autoryzowanych specjalistów (wykwalifikowanego elektryka). Lampa służy wyłącznie do oświetlenia i należy ją zamontować zgodnie z krajowymi przepisami wykonawczymi. Ostrożnie! Należy pamiętać, aby podczas prac związanych z okablowaniem i montażem oprawy i zasilacza były zawsze odłączone od sieci. W przeciwnym razie może dojść do zniszczenia modułów LED. Stosowanie wtyczki umożliwiającej podłączenie oprawy przy włączonym zasilaniu jest niedozwolone. Wtyczka ta może spowodować uszkodzenie oprawy i spowodować utratę gwarancji! Producent nie ponosi odpowiedzialności za szkody wynikłe z niewłaściwej instalacji, niewłaściwej obsługi lub wprowadzenia nieautoryzowanych zmian do oprawy. Źródło światła tej oprawy może wymieniać wyłącznie producent lub wyznaczony przez niego technik serwisowy lub inna osoba o podobnych kwalifikacjach. **Uwaga, ryzyko porażenia prądem!**



## **ZH** 装配、安装和操作说明!

灯具的安装、调试及任何变动仅可由经授权的专业人士（具有资质的电工）执行。灯具仅用于照明，并且需要根据国家的规定安装。注意！在灯具和供应单元的布线和安装过程中，一定要断电工作。不遵守规定会导致LED模块的损坏。严禁热插拔。热插拔可能导致灯具的损坏，以及保修失效！对于因错误安装、操作不当或擅自改动灯具而导致的损失，制造商概不负责。该灯具的光源仅可由制造商、制造商指定的技工或具有类似资质的人士替换。注意，有触电的危险！



## **AR**

### تعليمات التجميع والتركييب والتشغيل!

لا يجوز تجميع المصباح وتشغيله وأي تغييرات نظرًا على المصباح إلا من قبل الأشخاص المصرح لهم بذلك تم تنفيذها بواسطة متخصصين (كهربائي مؤهل).  
تستخدم وحدة الإضاءة للإضاءة فقط ويجب تركيبها وفقًا للوائح التركيب الوطنية.  
انتباه! اعمل دائمًا مع انقطاع التيار الكهربائي أثناء توصيل الأسلاك وتركيب المصابيح وإمدادات الطاقة.  
يمكن أن يؤدي عدم الالتزام إلى تدمير وحدات LED.

المكونات الإضافية الساخنة محظورة. قد يؤدي التوصيل الساخن إلى إتلاف المصباح وإلغاء الضمان!  
الشركة المصنعة غير مسؤولة عن التلف الناتج عن التركيب غير الصحيح أو التشغيل غير السليم أو التغييرات غير المصرح بها في الإضاءة.  
لا يجوز استبدال مصدر الضوء لهذا المصباح إلا من قبل الشركة المصنعة أو فني الخدمة المفوض من قبل الشركة المصنعة أو شخص مؤهل مماثل.  
تحذير خطر حدوث صدمة كهربائية!

