

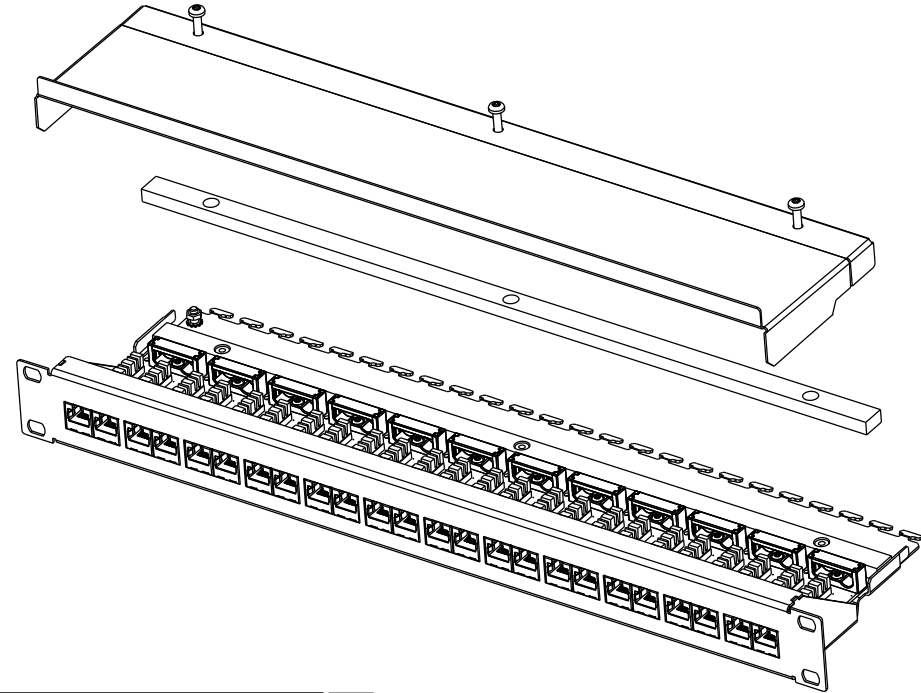

# LSA Patchpanel 19" 1HE 24x RJ45 Klasse E<sub>A</sub>

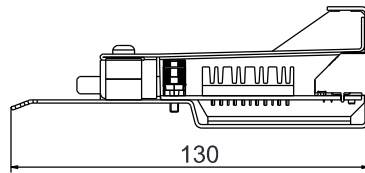

<b>Material</b>	Stahl verzinkt / steel zinc plated	<b>material</b>
<b>Oberfläche</b>	pulverbeschichtet / powder-coated	<b>surface</b>

<small>b a</small> Änd./ rev. Index	<small>Anpassung Neuerstellung</small> 27.07.2023 17.07.2023	<small>TG LE</small>	gez. / drawn 17.07.2023 LE gepr. / appr. 17.07.2023 MW	 Maße / Dimensions: mm Original: DIN A4 Blatt / sheet 1 von / of 2
	Titel / titel: LSA Patchpanel 19" 1HE 24 Port Klasse E <sub>A</sub>			
	Zeichnungsnummer/ drawing number: ZN-BL230123			

## Technische Daten / Technical Data

<b>Steckverbinder-Norm</b>	IEC 60603-7-51	<b>Connector standard</b>
<b>Mechanische Eigenschaften</b>		<b>Mechanische Eigenschaften</b>
Lebensdauer (Steckzyklen)	≥ 750	Insertion force
Steckkraft	≤ 30N	Life ( mating cycles RJ45, RJ12, RJ11)
<b>Werkstoffe</b>		<b>Materials</b>
Leiterplatte	FR4 UL94 V0	PCB
Oberfläche Schirmblech	Edelstahl / stainless steel	Shield finish
<b>Aderanschluss</b>		<b>Wire Connection</b>
Aderdurchmesser	0,40 - 0,63mm	Insulation diameter
<b>Umweltanforderungen</b>		<b>Environmental Requirements</b>
<b>Schutz vor Eindringen</b>		<b>Protection against Ingress</b>
Eindringen von Teilchen	IP2X	Particulate ingress
Wasser / Untertauchen	IPX0	Water / Immersion
<b>Klimatisch und chemisch</b>		<b>Climatical and Chemical</b>
Umgebungstemperatur	-40°C bis +70°C / -40°C to +70°C	Ambient temperature
<b>Elektrische Eigenschaften</b>		<b>Electrical Characteristics</b>
Kontaktwiderstand	≤ 20 mOhm	Contact resistance
Isolationswiderstand	≥ 500 mOhm	Insulation resistance
<b>Spannungsfestigkeit</b>		<b>Voltage Proof</b>
Kontakt-Kontakt	1000V	Contact-Contact
Kontakt-Schirm	1500V	Contact-Shield
<b>Übertragungstechnische Eigenschaften</b>		<b>Transimission Performance</b>
10 Gigabit Ethernet gemäß IEEE 802.3an	geeignet für 10 Gigabit Ethernet / adequate for 10 Gigabit Ethernet	10 Gigabit Ethernet acc. to IEEE 802.3an
Klasse E <sub>A</sub>	ISO/IEC 11801 ; DIN EN 50173-1	Class E <sub>A</sub>

								
				gez. / drawn	17.07.2023	LE		
				gepr. / appr.	17.07.2023	MW		
				Titel / titel:				
				LSA Patchpanel 19" 1HE 24 Port Klasse E <sub>A</sub>				Maße / Dimensions: mm
				Zeichnungsnummer/ drawing number:				Original: DIN A4
				ZN-BL230123				Blatt / sheet 2 von / of 2

b a	Anpassung Neuerstellung	27.07.2023 17.07.2023	TG LE				
Änd./ rev. Index	Änderung/ revision code	Datum/ date	Name/ name				